

---

## **Nortel Communication Server 1000**

Nortel Communication Server 1000 Release 4.5

---

# **Circuit Card**

## Description and Installation

Document Number: 553-3001-211

Document Release: Standard 3.00

Date: August 2005

---

Copyright © Nortel Networks Limited 2005

All Rights Reserved

Produced in Canada

Information is subject to change without notice. Nortel Networks reserves the right to make changes in design or components as progress in engineering and manufacturing may warrant.

Nortel, Nortel (Logo), the Globemark, This is the Way, This is Nortel (Design mark), SL-1, Meridian 1, and Succession are trademarks of Nortel Networks.

---



---

# Revision history

---

## August 2005

Standard 3.00. This document is up-issued to support Communication Server 1000 Release 4.5.

## September 2004

Standard 2.00. This document is up-issued for Communication Server 1000 Release 4.0.

## October 2003

Standard 1.00. This document is a new NTP for Succession 3.0. It was created to support a restructuring of the Documentation Library, which resulted in the merging of multiple legacy NTPs. This new document consolidates information previously contained in the following legacy documents, now retired:

- *Line Cards: Description* (553-3001-105)
- *Trunk Cards: Description* (553-3001-106)
- *Serial Data Interface Cards: Description* (553-3001-107)
- *NT7D16 Data Access Card: Description and operation* (553-3001-191)
- *Multi-purpose Serial Data Link: Description* (553-3001-195)
- *Circuit Cards: Installation and Testing* (553-3001-211)
- *Option 11C and 11C mini Technical Reference Guide* (553-3011-100) (Content from *Option 11C and 11C mini Technical Reference Guide* (553-3011-100) also appears in *Telephones and Consoles: Description, Installation, and Operation* (553-3001-367).)
- *Circuit Card Reference* (553-3023-211)



---

# Contents

---

<b>List of procedures</b> .....	<b>19</b>
<b>About this document</b> .....	<b>21</b>
Subject .....	21
Applicable systems .....	22
Intended audience .....	23
Conventions .....	24
Related information .....	25
<b>Overview</b> .....	<b>27</b>
Contents .....	27
Line cards .....	28
Trunk cards .....	59
Installation .....	61
Operation .....	63
Serial Data Interface (SDI) cards .....	72
<b>Circuit card installation</b> .....	<b>79</b>
Contents .....	79
Card slots — Large System .....	79
Circuit card installation .....	80
Precautions .....	84
Installing a circuit card .....	86

<b>Acceptance tests</b> .....	<b>89</b>
Contents .....	89
Introduction .....	89
Conference cards .....	90
Digitone receiver cards .....	92
Line cards .....	93
Multifrequency sender cards .....	94
Multifrequency signaling cards .....	95
Network cards .....	95
Trunk cards .....	96
Tone and digit switch cards .....	97
<b>Option settings</b> .....	<b>101</b>
Contents .....	101
Circuit card grid .....	102
NT1R20 Off-Premise Station card .....	104
NT5D12AA Dual DTI/PRI (DDP) card .....	107
NT6D42 Ringing Generator DC .....	114
NT5D2101/NT9D1102 Core/Network module backplane .....	117
NT6D68 Core module backplane .....	117
NT6D80 Multi-purpose Serial Data Link card .....	118
NT8D14 Universal Trunk card .....	119
NT8D15 E&M Trunk card .....	124
NT8D17 Conference/TDS card .....	125
NT8D21 Ringing Generator AC .....	126
NT8D22 System Monitor .....	127
NT8D41BA Quad Serial Data Interface Paddle Board .....	132
NT8D72 Primary Rate Interface card .....	134
QPC43 Peripheral Signaling card .....	136
QPC71 E&M/DX Signaling and Paging Trunk cards .....	136

QPC414 Network card . . . . .	137
QPC441 3-Port Extender cards . . . . .	138
QPC559, QPC560 Loop Signaling Trunk cards . . . . .	141
QPC528 CO/FX/WATS Trunk cards . . . . .	143
QPC471 Clock Controller card . . . . .	144
QPC525, QPC526, QPC527, QPC777 CO Trunk card . . . . .	145
QPC550 Direct Inward Dial Trunk card . . . . .	146
QPC551 Radio Paging Trunk card . . . . .	149
QPC595 Digitone Receiver cards . . . . .	150
QPC577, QPC596 Digitone Receiver daughterboards . . . . .	150
QPC720 Primary Rate Interface card . . . . .	150
QPC775 Clock Controller card . . . . .	152
QPC841 4-Port Serial Data Interface card . . . . .	153

**NT1R20 Off-Premise Station**

**Analog Line card . . . . . 157**

Contents . . . . .	157
Introduction . . . . .	157
Physical description . . . . .	158
Functional description . . . . .	160
Electrical specifications . . . . .	165
Operation . . . . .	168
Connector pin assignments . . . . .	172
Configuring the OPS analog line card . . . . .	174
Application . . . . .	175

**NT4N39AA CP Pentium IV Card . . . . . 183**

Contents . . . . .	183
Introduction . . . . .	183
Physical description . . . . .	183
Functional description . . . . .	186

Front panel connector pin assignments ..... 187

**NT5D11 and NT5D14 Lineside T1  
Interface cards ..... 193**

Contents ..... 193  
Introduction ..... 193  
Physical description ..... 194  
Functional description ..... 198  
Electrical specifications ..... 202  
Installation and configuration ..... 204  
Man-Machine T1 maintenance interface software ..... 225  
Applications ..... 244

**NT5D33 and NT5D34 Lineside E1  
Interface cards ..... 249**

Contents ..... 249  
Introduction ..... 249  
Physical description ..... 250  
Functional description ..... 255  
Electrical specifications ..... 261  
Installation and Configuration ..... 263  
Installation ..... 271  
Man-Machine E1 maintenance interface software ..... 284  
Applications ..... 310

**NT5D60/80 CLASS Modem card (XCMC) ..... 313**

Contents ..... 313  
Introduction ..... 313  
Physical description ..... 313  
Functional description ..... 314  
Electrical specifications ..... 317  
Configuration ..... 318



<b>NT5D97 Dual-port DTI2/PRI2 card</b> .....	<b>319</b>
Contents .....	319
Introduction .....	319
Physical description .....	320
Functional description .....	340
Architecture .....	353
Operation .....	359
 <b>NT5K02 Flexible Analog Line card</b> .....	 <b>367</b>
Contents .....	367
Introduction .....	367
Applications .....	368
 <b>NT5K21 XMFC/MFE card</b> .....	 <b>369</b>
Contents .....	369
Introduction .....	369
MFC signaling .....	369
MFE signaling .....	372
Sender and receiver mode .....	373
Physical specifications .....	376
 <b>NT6D70 SILC Line card</b> .....	 <b>379</b>
Contents .....	379
Introduction .....	379
Physical description .....	380
Functional description .....	380
 <b>NT6D71 UILC Line card</b> .....	 <b>385</b>
Contents .....	385
Introduction .....	385
Physical description .....	385
Functional description .....	386

<b>NT6D80 MSDL card</b> .....	<b>389</b>
Contents .....	389
Introduction .....	389
Physical description .....	390
Functional description .....	392
Engineering guidelines .....	397
Installation .....	404
Maintenance .....	413
Replacing MSDL cards .....	421
Symptoms and actions .....	422
System disabled actions .....	423
<b>NT7D16 Data Access card</b> .....	<b>427</b>
Content list .....	427
Introduction .....	428
Features .....	428
Controls and indicators .....	429
Dialing operations .....	430
Operating modes .....	435
Keyboard dialing .....	472
Hayes dialing .....	485
Specifications .....	497
System database requirements .....	500
Power supply .....	504
Installing the Data Access card .....	505
Port configuration .....	507
Cabling .....	509
Backplane pinout and signaling .....	514
Configuring the Data Access card .....	517
Connecting Apple Macintosh to the DAC .....	522

---

Upgrading systems . . . . .	522
<b>NT8D02 and NTDK16 Digital Line cards . . . . .</b>	<b>527</b>
Contents . . . . .	527
Introduction . . . . .	527
Physical description . . . . .	528
Functional description . . . . .	530
Electrical specifications . . . . .	536
Digital line interface specifications . . . . .	537
Connector pin assignments . . . . .	539
Configuration . . . . .	541
<b>NT8D03 Analog Line card . . . . .</b>	<b>545</b>
Overview . . . . .	545
<b>NT8D09 Analog Message Waiting Line card . . . . .</b>	<b>547</b>
Contents . . . . .	547
Introduction . . . . .	547
Physical description . . . . .	549
Functional description . . . . .	549
Connector pin assignments . . . . .	558
Configuration . . . . .	561
<b>NT8D14 Universal Trunk card . . . . .</b>	<b>565</b>
Contents . . . . .	565
Introduction . . . . .	565
Physical description . . . . .	567
Functional description . . . . .	570
Operation . . . . .	573
Electrical specifications . . . . .	609
Connector pin assignments . . . . .	614

Configuration . . . . .	615
Applications . . . . .	624
<b>NT8D15 E&amp;M Trunk card . . . . .</b>	<b>627</b>
Contents . . . . .	627
Introduction . . . . .	627
Physical description . . . . .	629
Functional description . . . . .	631
Operation . . . . .	641
Electrical specifications . . . . .	652
Connector pin assignments . . . . .	655
Configuration . . . . .	658
Applications . . . . .	664
<b>NT8D41AA Serial Data Interface Paddle Board . . . . .</b>	<b>667</b>
Contents . . . . .	667
Introduction . . . . .	667
Physical description . . . . .	668
Functional description . . . . .	670
Connector pin assignments . . . . .	671
Configuring the SDI paddle board . . . . .	672
Applications . . . . .	678
<b>NT8D41BA Quad Serial Data Interface Paddle Board . . . . .</b>	<b>681</b>
Contents . . . . .	681
Introduction . . . . .	681
Physical description . . . . .	682
Functional description . . . . .	682
Connector pin assignments . . . . .	685
Configuring the QSDI paddle board . . . . .	687

---

Applications . . . . .	692
<b>NTAG26 XMFR card . . . . .</b>	<b>695</b>
Contents . . . . .	695
Introduction . . . . .	695
Physical specifications . . . . .	700
<b>NTAK02 SDI/DCH card . . . . .</b>	<b>701</b>
Contents . . . . .	701
Introduction . . . . .	701
NTAK02 SDI/DCH card . . . . .	701
<b>NTAK09 1.5 Mb DTI/PRI card . . . . .</b>	<b>709</b>
Contents . . . . .	709
Introduction . . . . .	709
Physical description . . . . .	710
Functional description . . . . .	714
Architecture . . . . .	715
<b>NTAK10 2.0 Mb DTI card . . . . .</b>	<b>721</b>
Contents . . . . .	721
Introduction . . . . .	721
Physical description . . . . .	722
Functional description . . . . .	723
Architecture . . . . .	724
<b>NTAK20 Clock Controller daughterboard . . . . .</b>	<b>735</b>
Contents . . . . .	735
Introduction . . . . .	735
Physical description . . . . .	738
Functional description . . . . .	739

<b>NTAK79 2.0 Mb PRI card</b> .....	<b>745</b>
Contents .....	745
Introduction .....	745
Physical description .....	746
Functional description .....	751
Architecture .....	752
<b>NTAK93 D-channel Handler Interface daughterboard</b> .....	<b>763</b>
Contents .....	763
Introduction .....	763
Physical description .....	764
Functional description .....	765
<b>NTBK22 MISP card</b> .....	<b>769</b>
Contents .....	769
Introduction .....	769
Physical description .....	769
Functional description .....	770
<b>NTBK50 2.0 Mb PRI card</b> .....	<b>773</b>
Contents .....	773
Introduction .....	773
Physical description .....	774
Functional description .....	777
Architecture .....	778
<b>NTBK51 Downloadable D-channel Handler daughterboard</b> .....	<b>785</b>
Contents .....	785
Introduction .....	785
Physical description .....	786

---

Functional description .....	787
Download operation .....	789
<b>NTCK16 Generic Central Office</b>	
<b>Trunk cards .....</b>	<b>791</b>
Contents .....	791
Introduction .....	791
Physical description .....	793
Functional description .....	793
Operation .....	794
Electrical specifications .....	796
Connector pin assignments .....	797
Configuration .....	797
Applications .....	807
<b>NTDK20 Small System</b>	
<b>Controller card .....</b>	<b>811</b>
Contents .....	811
Introduction .....	811
Memory .....	814
100BaseT IP daughterboards .....	815
PC card interface .....	818
Security device .....	819
SDI ports .....	820
Conferencing .....	820
MG 1000S/Expansion card slot assignment .....	821
<b>NTRB21 DTI/PRI/DCH TMDI card .....</b>	<b>825</b>
Contents .....	825
Introduction .....	825
Physical description .....	826
Functional description .....	830

Software description . . . . .	831
Hardware description . . . . .	831
Architecture . . . . .	831
<b>NTVQ01xx Media Card . . . . .</b>	<b>839</b>
Contents . . . . .	839
Physical description . . . . .	839
Hardware architecture . . . . .	841
Functional description . . . . .	843
Survivability . . . . .	843
<b>NTVQ55AA ITG Pentium card . . . . .</b>	<b>845</b>
Contents . . . . .	845
Physical description . . . . .	845
Functional description . . . . .	846
<b>QPC513 Enhanced Serial Data Interface card . . . . .</b>	<b>851</b>
Contents . . . . .	851
Introduction . . . . .	851
Physical description . . . . .	852
Functional description . . . . .	854
Connector pin assignments . . . . .	859
Configuring the ESDI card . . . . .	862
Applications . . . . .	867
<b>QPC841 Quad Serial Data Interface card . . . . .</b>	<b>869</b>
Contents . . . . .	869
Introduction . . . . .	869
Physical description . . . . .	870
Functional description . . . . .	872
Connector pin assignments . . . . .	874



Configuring the QSDI card .....	876
Applications .....	882
<b>The TDS/DTR card .....</b>	<b>885</b>
Contents .....	885
Introduction .....	885
Features .....	886
<b>Appendix A: LAPB Data Link Control protocol .....</b>	<b>901</b>
Contents .....	901
Introduction .....	901
Operation .....	901
Frame structure .....	902
LAPB balanced class of procedure .....	903
Commands and responses .....	904
Description of procedure .....	905



---

# List of procedures

---

<b>Procedure 1</b>	
<b>Installation</b> .....	<b>86</b>
<b>Procedure 2</b>	
<b>Testing conference cards</b> .....	<b>90</b>
<b>Procedure 3</b>	
<b>Testing digitone receiver cards</b> .....	<b>92</b>
<b>Procedure 4</b>	
<b>Testing line cards</b> .....	<b>93</b>
<b>Procedure 5</b>	
<b>Testing multifrequency sender cards</b> .....	<b>94</b>
<b>Procedure 6</b>	
<b>Testing multifrequency signaling cards</b> .....	<b>95</b>
<b>Procedure 7</b>	
<b>Testing network cards</b> .....	<b>95</b>
<b>Procedure 8</b>	
<b>Testing a trunk card using a maintenance telephone</b> ..	<b>96</b>
<b>Procedure 9</b>	
<b>Testing a trunk card using a system terminal</b> .....	<b>96</b>
<b>Procedure 10</b>	
<b>Testing tone and digit switch cards</b> .....	<b>97</b>

<b>Procedure 11</b>	
<b>Connecting to the MDF</b> .....	<b>215</b>
<b>Procedure 12</b>	
<b>Connecting two or more lineside T1 cards to the MMI terminal</b> .....	<b>220</b>
<b>Procedure 13</b>	
<b>Connecting two or more LEIs to the MMI terminal</b> ...	<b>279</b>
<b>Procedure 14</b>	
<b>Installing the NT5D97</b> .....	<b>363</b>
<b>Procedure 15</b>	
<b>Removing the NT5D97</b> .....	<b>364</b>
<b>Procedure 16</b>	
<b>Installing the MSDL card</b> .....	<b>407</b>
<b>Procedure 17</b>	
<b>Cabling the MSDL card to the PRI card</b> .....	<b>410</b>
<b>Procedure 18</b>	
<b>Cabling the MSDL card to the I/O panel</b> .....	<b>411</b>
<b>Procedure 19</b>	
<b>Replacing an MSDL card</b> .....	<b>421</b>

---

## About this document

---

This document is a global document. Contact your system supplier or your Nortel representative to verify that the hardware and software described are supported in your area.

### Subject

This document outlines the functions, specifications, applications, and operation of the various circuit cards.

**Note 1:** Line cards – This information is intended to be used as a guide when connecting the line cards to customer-provided station equipment.

**Note 2:** Trunk cards – This information is intended to be used as a guide when connecting the trunk cards to customer-provided equipment and central office trunk facilities.

**Note 3:** MSDL card – This card provides multiple interface types with four full-duplex serial I/O ports that can be independently configured for various operations. Peripheral software downloaded to the MSDL controls functionality for each port.

**Note 4:** Synchronous operation is permitted on all MSDL ports. Port 0 can be configured as an asynchronous Serial Data Interface (SDI).

For detailed procedures for removing a specific circuit card and installing a replacement, see *Communication Server 1000M and Meridian 1: Large System Maintenance* (553-3021-500).

For a description of all administration programs and maintenance programs, see the *Software Input/Output: Administration* (553-3001-311). For

information about system messages, see the *Software Input/Output: System Messages* (553-3001-411).

### **Note on legacy products and releases**

This NTP contains information about systems, components, and features that are compatible with Nortel Communication Server 1000 Release 4.5 software. For more information on legacy products and releases, click the **Technical Documentation** link under **Support & Training** on the Nortel home page:

[www.nortel.com](http://www.nortel.com)

## **Applicable systems**

This document applies to the following systems:

- Communication Server 1000S (CS 1000S)
- Communication Server 1000M Chassis (CS 1000M Chassis)
- Communication Server 1000M Cabinet (CS 1000M Cabinet)
- Communication Server 1000M Half Group (CS 1000M HG)
- Communication Server 1000M Single Group (CS 1000M SG)
- Communication Server 1000M Multi Group (CS 1000M MG)
- Communication Server 1000E (CS 1000E)
- Meridian 1 PBX 11C Chassis
- Meridian 1 PBX 11C Cabinet
- Meridian 1 PBX 51C
- Meridian 1 PBX 61C
- Meridian 1 PBX 81
- Meridian 1 PBX 81C

**Note:** When upgrading software, memory upgrades may be required on the Signaling Server, the Call Server, or both.

## System migration

When particular Meridian 1 systems are upgraded to run CS 1000 Release 4.5 software and configured to include a Signaling Server, they become CS 1000M systems. Table 1 lists each Meridian 1 system that supports an upgrade path to a CS 1000M system.

**Table 1**  
**Meridian 1 systems to CS 1000M systems**

This Meridian 1 system...	Maps to this CS 1000M system
Meridian 1 PBX 11C Chassis	CS 1000M Chassis
Meridian 1 PBX 11C Cabinet	CS 1000M Cabinet
Meridian 1 PBX 51C	CS 1000M Half Group
Meridian 1 PBX 61C	CS 1000M Single Group
Meridian 1 PBX 81	CS 1000M Multi Group
Meridian 1 PBX 81C	CS 1000M Multi Group

For more information, see one or more of the following NTPs:

- *Communication Server 1000M and Meridian 1: Small System Upgrade Procedures (553-3011-258)*
- *Communication Server 1000M and Meridian 1: Large System Upgrade Procedures (553-3021-258)*
- *Communication Server 1000S: Upgrade Procedures (553-3031-258)*
- *Communication Server 1000E: Upgrade Procedures (553-3041-258)*

## Intended audience

This document is intended for individuals responsible for maintaining Internet Enabled systems.

## Conventions

### Terminology

In this document, the following systems are referred to generically as “system”:

- Communication Server 1000S (CS 1000S)
- Communication Server 1000M (CS 1000M)
- Communication Server 1000E (CS 1000E)
- Meridian 1

The following systems are referred to generically as “Small System”:

- Communication Server 1000M Chassis (CS 1000M Chassis)
- Communication Server 1000M Cabinet (CS 1000M Cabinet)
- Meridian 1 PBX 11C Chassis
- Meridian 1 PBX 11C Cabinet

The following systems are referred to generically as “Large System”:

- Communication Server 1000M Half Group (CS 1000M HG)
- Communication Server 1000M Single Group (CS 1000M SG)
- Communication Server 1000M Multi Group (CS 1000M MG)
- Meridian 1 PBX 51C
- Meridian 1 PBX 61C
- Meridian 1 PBX 81
- Meridian 1 PBX 81C



## Related information

This section lists information sources that relate to this document.

### NTPs

The following NTPs are referenced in this document:

- *Meridian Link ISDN/AP General Guide* (553-2901-100)
- *Spares Planning* (553-3001-153)
- *Equipment Identification* (553-3001-154)
- *Transmission Parameters* (553-3001-182)
- *System Management* (553-3001-300)
- *Features and Services* (553-3001-306)
- *Software Input/Output: Administration* (553-3001-311)
- *Telephones and Consoles: Description, Installation, and Operation* (553-3001-367)
- *Software Input/Output: System Messages* (553-3001-411)
- *Software Input/Output: Maintenance* (553-3001-511)
- *Communication Server 1000M and Meridian 1: Large System Planning and Engineering* (553-3021-120)
- *Communication Server 1000M and Meridian 1: Large System Installation and Configuration* (553-3021-210)
- *Communication Server 1000M and Meridian 1: Large System Maintenance* (553-3021-500)
- *Communication Server 1000S: Installation and Configuration* (553-3031-210)
- *Meridian Link description* (553-3201-110)

### Online

To access Nortel documentation online, click the **Technical Documentation** link under **Support & Training** on the Nortel home page:

[www.nortel.com](http://www.nortel.com)

### **CD-ROM**

To obtain Nortel documentation on CD-ROM, contact your Nortel customer representative.

---

# Overview

---

## Contents

This section contains information on the following topics:

Line cards . . . . .	28
Installation . . . . .	30
Operation . . . . .	31
Analog line interface units . . . . .	37
Digital line interface units . . . . .	40
Analog line call operation . . . . .	42
Digital line call operation . . . . .	46
Lineside T1 call operation . . . . .	46
Voice frequency audio level . . . . .	57
Off-premise line protection . . . . .	57
Line protectors . . . . .	57
Line protection grounding . . . . .	58
Line and telephone components . . . . .	59
Trunk cards . . . . .	59
Host interface bus . . . . .	63
Trunk interface unit . . . . .	69
Serial Data Interface (SDI) cards . . . . .	72
Uses . . . . .	73
Features . . . . .	73
Specifications . . . . .	74
Installation . . . . .	76
Maintenance . . . . .	76

## Line cards

The following line cards are designed using the Intelligent Peripheral Equipment (IPE) architecture and are recommended for use in all new system designs.

Each of the line cards was designed to fit a specific system need. Table 2 lists the line card characteristics.

**Table 2**  
**Line card characteristics**

Part Number	Description	Lines	Line Type	Message Waiting	Supervised Analog Lines	Architecture
NT1R20	Off-premise station analog line card	8	Analog	Interrupted dial tone	Yes	IPE
NT5D11	Lineside T1 Interface card	24	T1	None	Yes	IPE
NT5D33/34	Lineside E1 Interface card	30	E1	None	Yes	IPE
NT8D02	Digital Line card (16 voice/16 data)	16	Digital	Message waiting signal forwarded to digital phone for display	No	IPE
NT8D09	Analog Message Waiting Line card	16	Analog	Lamp	No	IPE

### **NT1R20 Off-Premise Station Analog Line card**

The NT1R20 Off-Premise Station (OPS) Analog Line card is an intelligent eight-channel analog line card designed to be used with 2-wire analog terminal equipment such as analog (500/2500-type) telephones and analog modems. Each line has integral hazardous and surge voltage protection to protect the system from damage due to lightning strikes and accidental power line connections. This card is normally used whenever the phone lines have to leave the building in which the switch is installed. The OPS line card supports message waiting notification by interrupting the dial tone when the receiver is first picked up. It also provides battery reversal answer and disconnect analog line supervision and hook flash disconnect analog line supervision features.

### **NT5D11 lineside T1 interface card**

The NT5D11 lineside T1 Interface card is an intelligent 24-channel digital line card that is used to connect the switch to T1 compatible terminal equipment on the lineside. T1 compatible terminal equipment includes voice mail systems, channel banks containing FXS cards, and key systems such as the Nortel Norstar. The lineside T1 card differs from trunk T1 cards in that it supports terminal equipment features such as hook-flash, transfer, hold, and conference. It emulates an analog line card to the system software.

### **NT5D33 and NT5D34 Lineside E1 Interface card**

The NT5D33/34 Lineside E1 Interface card is an intelligent 30-channel digital line card that is used to connect the switch to E1 compatible terminal equipment on the lineside. E1 compatible terminal equipment includes voice mail systems. The lineside E1 card emulates an analog line card to the system software.

### **NT8D02 digital line card**

The NT8D02 Digital Line card is an intelligent 16-channel digital line card that provides voice and data communication links between a CS 1000S, CS 1000M, and Meridian 1 switch and modular digital telephones. Each of the 16 channels support voice-only or simultaneous voice and data service over a single twisted pair of standard telephone wire.

### NT8D09 analog message waiting line card

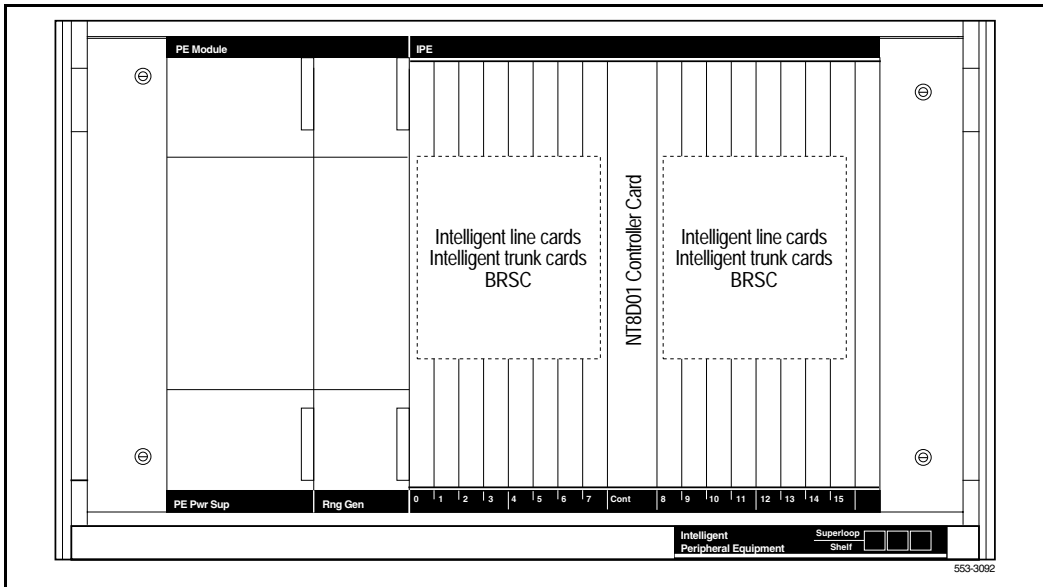
The NT8D09 Analog Message Waiting Line card is an intelligent 16-channel analog line card designed to be used with 2-wire terminal equipment such as analog (500/2500-type) telephones, modems, and key systems. This card can also provide a high-voltage, low-current signal on the Tip and Ring pair of each line to light the message waiting lamp on phones equipped with that feature.

## Installation

This section provides a high-level description of how to install and test line cards.

IPE line cards can be installed in any slot of the NT8D37 IPE module. Figure 1 shows where an IPE line card can be installed in an NT8D37 IPE module.

**Figure 1**  
IPE line cards shown installed in an NT8D37 IPE module



When installing line cards, follow these general procedures:

- Configure the jumpers and switches on the line card (if any) to meet system needs.
- Install the line card into the selected slot.
- Install the cable that connects the backplane connector on the IPE module to the module I/O panel.
- Connect a 25-pair cable from the module I/O panel connector to the Main Distribution Frame (MDF).
- Connect the line card output to the selected terminal equipment at the MDF.
- Configure the individual line interface unit using the Analog (500/2500-type) Telephone Administration program LD 10 for analog line interface units and Multi-line Telephone Administration program LD 11 for digital line interface units.

Once these steps have been completed, the terminal equipment is ready for use.

## Operation

This section describes how line cards fit into the CS 1000S, CS 1000M, and Meridian 1 architecture, the busses that carry signals to and from the line cards, and how they connect to terminal equipment. These differences are summarized in Table 3 on [page 32](#).

### Host interface bus

Cards based on the IPE bus have a built-in microcontroller. The IPE microcontroller is used to do the following:

- perform local diagnostics (self-test)

- configure the card according to instructions issued by the system
- report back to the system information such as card identification (type, vintage, and serial number), firmware version, and programmed configuration status)

**Table 3**  
**IPE module architecture**

Parameter	IPE
Card Dimensions	31.75 x 25.4 x 2.2 cm. (12.5 x10.0 x 0.875 in.)
Network Interface	DS-30X Loops
Communication Interface	card LAN Link
Microcontroller	8031 / 8051 Family
Peripheral Interface card	NT8D01 Controller card
Network Interface card	NT8D04 Superloop Network card
Modules	NT8D37 IPE module

### Intelligent Peripheral Equipment

IPE line cards all have a similar architecture. Figure 2 on [page 34](#) shows a typical IPE line card architecture. The various line cards differ only in the number and types of line interface units.

The switch communicates with IPE modules over two separate interfaces. Voice and signaling data are sent and received over DS-30X loops, and maintenance data is sent over a separate asynchronous communication link called the card LAN link.

Signaling data is information directly related to the operation of the telephone line. Some examples of signaling commands include:

- off-hook/on-hook

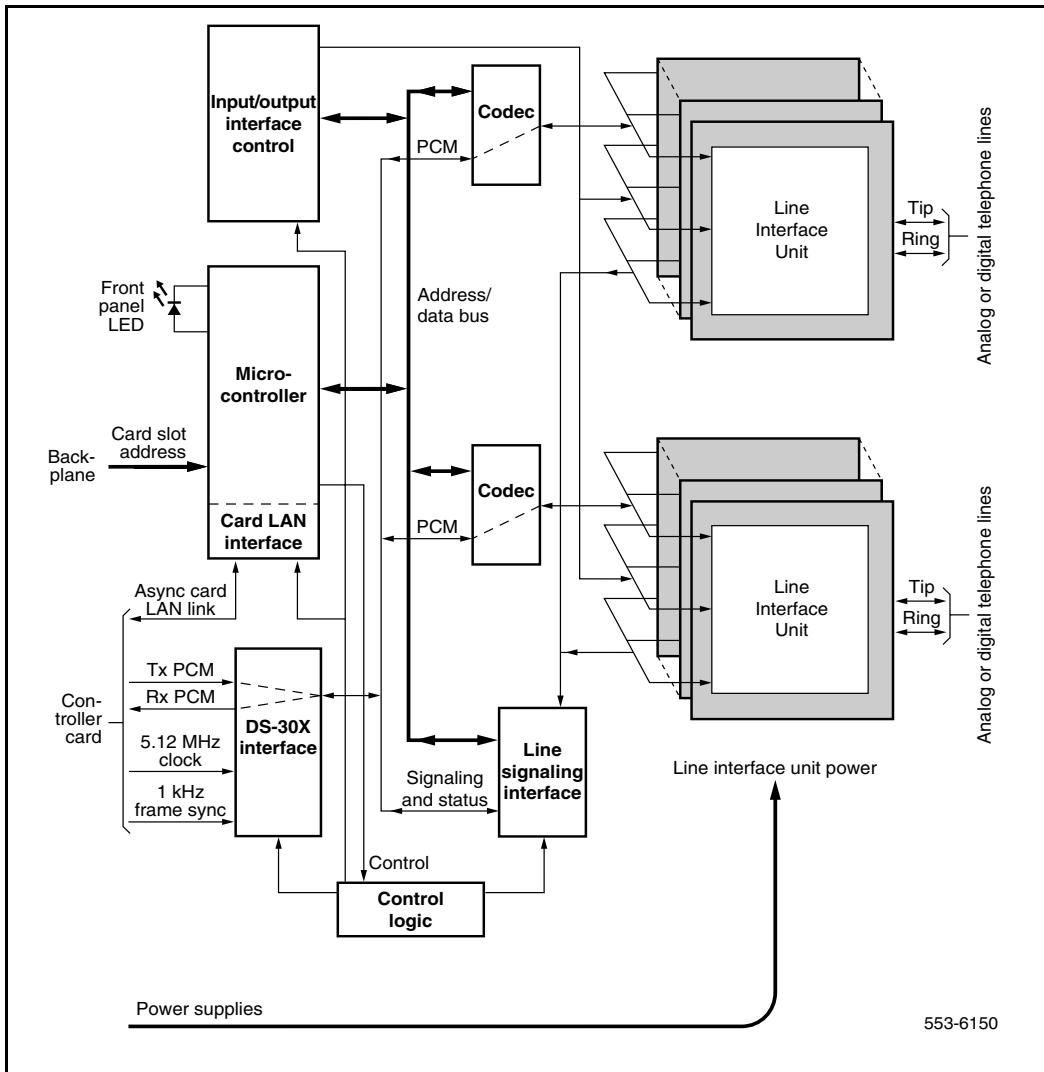


- ringing signal on/off
- message waiting lamp on/off

Maintenance data is data relating to the configuration and operation of the IPE card, and is carried on the card LAN link. Some examples of maintenance data include:

- polling
- reporting of self-test status
- CP initiated card reset
- reporting of card ID (card type and hardware vintage)
- reporting of firmware version
- downloading line interface unit parameters
- reporting of line interface unit configuration
- enabling/disabling of the DS-30X network loop bus
- reporting of card status or T1 link status

**Figure 2**  
**Typical IPE analog line card architecture**



### ***DS-30X loops***

The line interfaces provided by the line cards connect to conventional 2-wire (tip and ring) line facilities. IPE analog line cards convert the incoming analog voice and signaling information to digital form and route it to the Call Server over DS-30X network loops. Conversely, digital voice and signaling information from the Call Server is sent over DS-30X network loops to the analog line cards where it is converted to analog form and applied to the line facility.

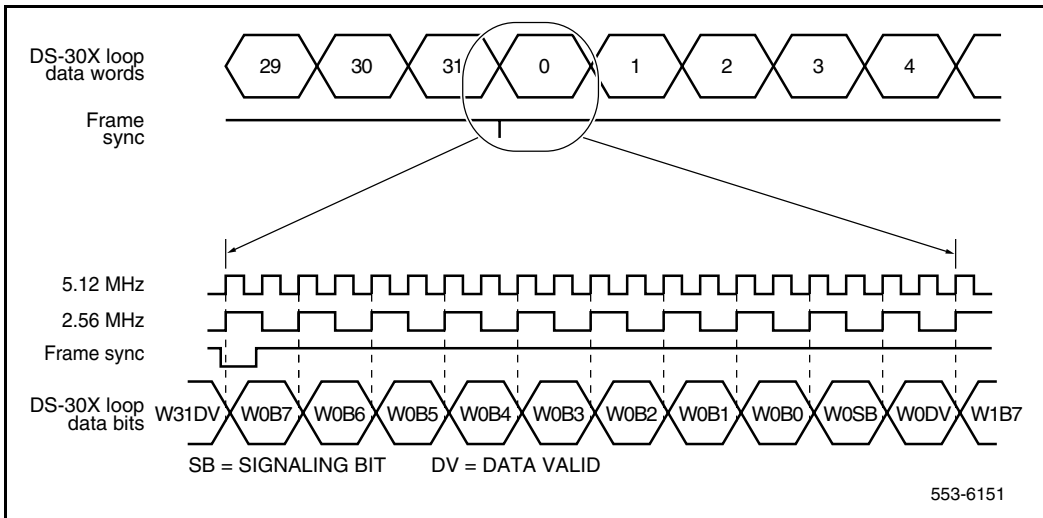
IPE digital line cards receive the data from the digital phone terminal as 512 kHz Time Compressed Multiplexed (TCM) data. The digital line card converts that data to a format compatible with the DS-30X loop and transmits it in the next available timeslot. When a word is received from the DS-30X loop, the digital line card converts it to the TCM format and transmits it to the digital phone terminal over the digital line facility.

A separate dedicated DS-30X network loop is extended between each IPE line/trunk card and the controller cards within an IPE module. A DS-30X network loop is composed of two synchronous serial data buses. One bus transports in the Transmit (Tx) direction towards the line facility and the other in the Receive (Rx) direction towards the CS 1000S, CS 1000M, and Meridian 1.

Each bus has 32 channels for Pulse Code Modulated (PCM) voice data. Each channel consists of a 10-bit word. See Figure 3 on [page 36](#). Eight of the 10 bits are for PCM data, one bit is the call signaling bit, and the last bit is a data valid bit. The eight-bit PCM portion of a channel is called a timeslot. The DS-30X loop is clocked at 2.56 Mbps (one-half the 5.12 MHz clock frequency supplied by the controller card). Thus, the timeslot repetition rate for a single channel is 8 kHz. The controller card also supplies a locally generated 1 kHz frame sync signal for channel synchronization.

Signaling data is transmitted to and from the line cards using the call signaling bit within the 10-bit channel. When the line card detects a condition that the switch needs to know about, it creates a 24-bit signaling word. This word is shifted out on the signaling bit for the associated channel one bit at a time during 24 successive DS-30X frames. Conversely, when the switch sends signaling data to the line card, it is sent as a 24-bit word divided among 24 successive DS-30X frames.

**Figure 3**  
**DS-30X loop data format**



DS-30Y network loops extend between controller cards and superloop network cards in the Common Equipment (CE). They function in a manner similar to DS-30X loops. See Figure 5 on [page 41](#).

A DS-30Y loop carries the PCM timeslot traffic of a DS-30X loop. Four DS-30Y network loops form a superloop with a capacity of 128 channels (120 usable timeslots). See *Communication Server 1000M and Meridian 1: Large System Planning and Engineering (553-3021-120)* for more information on superloops.

**Card LAN link**

Maintenance communication is the exchange of control and status data between IPE line or trunk cards and the Call Server by way of the NT8D01 Controller card. Maintenance data is transported through the *card LAN link*. This link is composed of two asynchronous serial buses (called the Async card LAN link in Figure 2 on [page 34](#)). The output bus is used by the system controller for output of control data to the line card. The input bus is used by the system controller for input of line card status data.

A card LAN link bus is common to all of the line/trunk card slots within an IPE module. This bus is arranged in a master/slave configuration where the controller card is the master and all other cards are slaves. The module backplane provides each line/trunk card slot with a unique hardwired slot address. This slot address enables a slave card to respond when addressed by the controller card. The controller card communicates with only one slave at a time.

In normal operation, the controller card continually scans (polls) all of the slave cards connected to the card LAN to monitor their presence and operational status. The slave card sends replies to the controller on the input bus along with its card slot address for identification. In its reply, the slave informs the controller if any change in card status has taken place. The controller can then prompt the slave for specific information. Slaves only respond when prompted by the controller; they do not initiate exchange of control or status data on their own.

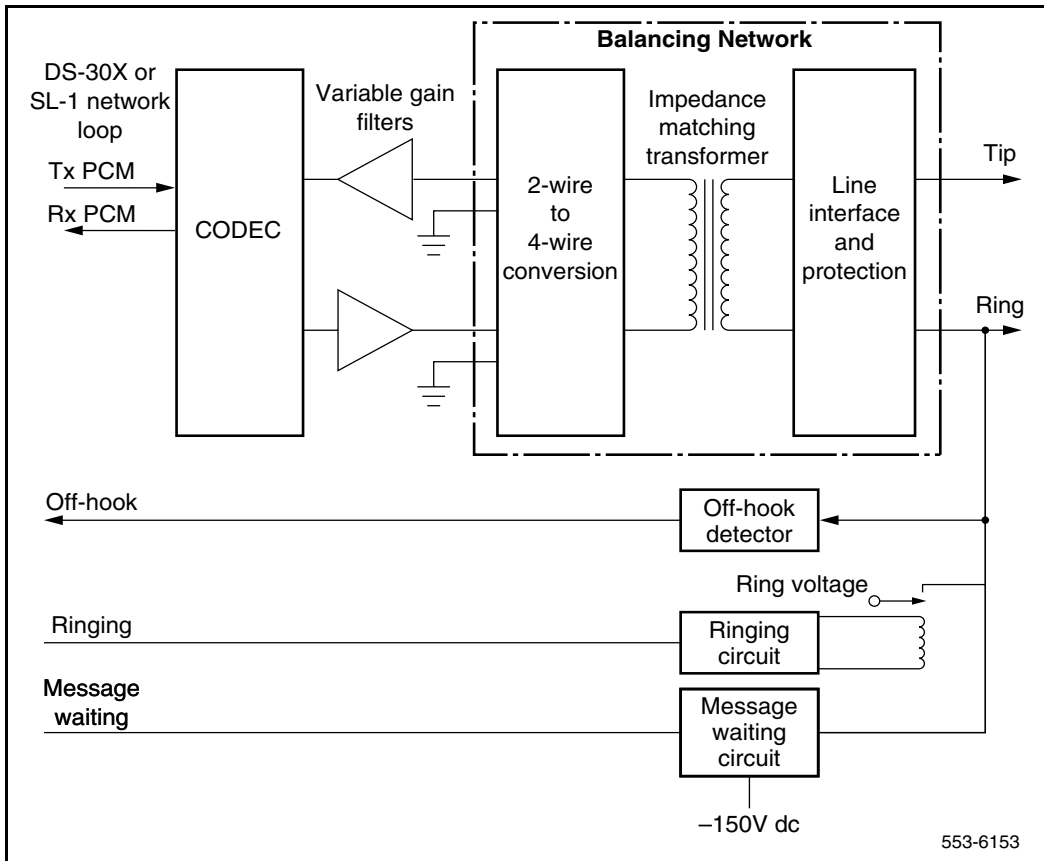
When an IPE line card is first plugged into the backplane, it runs a self-test. When the self-test is completed, a properly functioning card responds to the next controller card poll with the self-test status. The controller then queries for card identification and other status information. The controller then downloads all applicable configuration data to the line card, initializes it, and puts it into an operational mode.

## Analog line interface units

Once the 8-bit digital voice signal has been received by the analog line card, it must be converted back into an analog signal, filtered, converted from a 4-wire transmission path to a 2-wire transmission path, and driven onto the analog telephone line.

Figure 4 on [page 38](#) shows a typical example of the logic that performs these functions. Each part of the analog line interface unit is discussed in the following section.

**Figure 4**  
Typical analog line interface unit block diagram



553-6153

### **Coder/Decoder circuit**

The Coder/Decoder (CODEC) performs Analog to Digital (A/D) and Digital to Analog (D/A) conversion of the line analog voiceband signal to and from a digital PCM signal. This signal can be coded and decoded using either the A-Law or the  $\mu$ -Law companding algorithm.

On some analog line cards, the decoding algorithm depends of the type of CODEC installed when the board is built. On others, it is an option selected using a software overlay.

### **Variable gain filters**

Audio signals received from the analog phone line are passed through a low-pass A/D monolithic filter that limits the frequency spread of the input signal to a nominal 200 to 3400 Hz bandwidth. The audio signal is then applied to the input of the CODEC. Audio signals coming from the CODEC are passed through a low-pass A/D monolithic filter that integrates the amplitude modulated pulses coming from the CODEC, and then filters and amplifies the result. On some of the line cards, the gain of these filters can be programmed by the system controller. This allows the system to make up for line losses according to the loss plan.

### **Balancing network**

Depending on the card type, the balancing network provides a 600  $\frac{3}{4}$ , 900  $\frac{3}{4}$ , 3COM or 3CM2 impedance matching network. It also converts the 2-wire transmission path (tip and ring) to a 4-wire transmission path (Rx/ground and Tx/ground). The balancing network is usually a transformer/analog (hybrid) circuit combination, but can also be a monolithic Subscriber Line Interface Circuit (SLIC) on the newer line cards.

### **Line interface and foreign voltage protection**

The line interface unit connects the balancing network to the telephone tip and ring pairs. The off-premise line card (NT1R20) has circuitry that protects the line card from foreign voltage surges caused by accidental power line connections and lightning surges. This protection is necessary if the telephone line leaves the building where the switch is installed.

The line interface unit has a relay that applies the ringing voltage onto the phone line. See Figure 4 on [page 38](#). The RSYNC signal from the 20 Hz

(nominal) ringing voltage power supply is used to prevent switching of the relay during the current peak. This eliminates switching glitches and extends the life of the switching relay.

The off-hook detection circuit monitors the current draw on the phone line. When the current draw exceeds a preset value, the circuit generates an off-hook signal that is transmitted back to the system controller.

The message waiting circuit on message waiting line cards monitors the status of the message waiting signal and applies –150 V dc power to the tip lead when activated. This voltage is used to light the message waiting lamps on phones that are equipped with that feature. The high voltage supply is automatically disconnected when the phone goes off-hook. Newer line cards can sense when the message waiting lamp is not working and can report that information back to the system controller.

## Digital line interface units

The NT8D02 digital line card provides voice and data communication links between a switch and modular digital telephones. These lines carry multiplexed PCM voice, data and signaling information as Time Compression Multiplexed (TCM) loops. Each TCM loop can be connected to a Nortel “Meridian Modular Digital” telephone.

The digital line interface card contains one or more digital line interface units. See Figure 5 on [page 41](#). Each digital line interface unit contains a Digital Line Interface Circuit (DLIC). The purpose of each DLIC is to demultiplex data from the DS-30X Tx channel into integrated voice and data bitstreams and transmit those bitstreams as Bi-Polar Return to Zero, Alternate Mark Inversion (BPRZ-AMI) data to the TCM loop. It also does the opposite: receives BPRZ-AMI bitstreams from the TCM loop and multiplexes the integrated voice and data bitstream onto the DS-30X Rx channel.

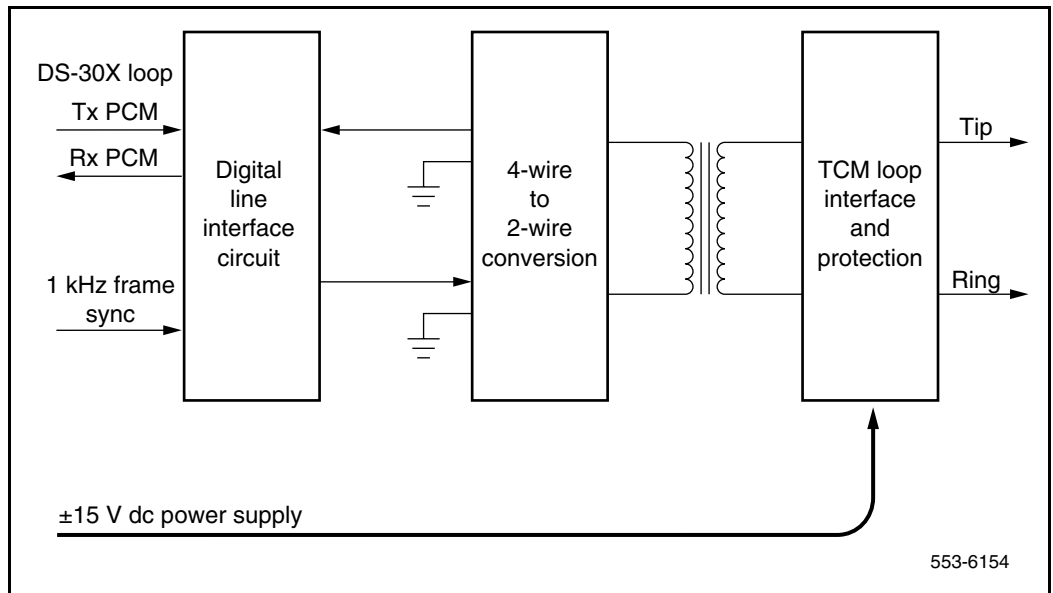
The 4-wire to 2-wire conversion circuit converts the 2-wire tip and ring leads into a 4-wire (Tx and ground and RX and ground) signal that is compatible with the digital line interface circuit.

### TCM loop interfaces

Each digital phone line terminates on the digital line card at a TCM loop interface circuit. The circuit provides transformer coupling and foreign



**Figure 5**  
**Digital line interface unit block diagram**



voltage protection between the TCM loop and the digital line interface circuit. It also provides power for the digital telephone.

To prevent undesirable side effects from occurring when the TCM loop interface cannot provide the proper signals on the digital phone line, the system controller can remove the  $\pm 15$  V dc power supply from the TCM loop interface. This happens when either the card gets a command from the NT8D01 Controller card to shut down the channel, or when the digital line card detects a loss of the 1 KHz frame synchronization signal.

Each TCM loop interface circuit can service loops up to 3500 ft. in length when using 24 gauge wire. The circuit allows for a maximum ac signal loss of 15.5 dB at 256 KHz and a maximum DC loop resistance of 210 ohms.

### Signaling

The digital line interface units also contain signaling and control circuits that establish, monitor, and take down call connections. These circuits work with

the system controller to operate the digital line interface circuits during calls. The circuits receive outgoing call signaling messages from the controller and return incoming call status information to the controller over the DS-30X network loop.

## Analog line call operation

The applications, features, and signalling arrangements for each line interface unit are configured in software and implemented on the card through software download messages. When an analog line interface unit is idle, it provides a voltage near ground on the tip lead and a voltage near  $-48$  V dc on the ring lead to the near-end station. (The near-end station is the telephone or device that is connected to the analog line card by the tip and ring leads.) An on-hook telephone presents a high impedance toward the line interface unit on the card.

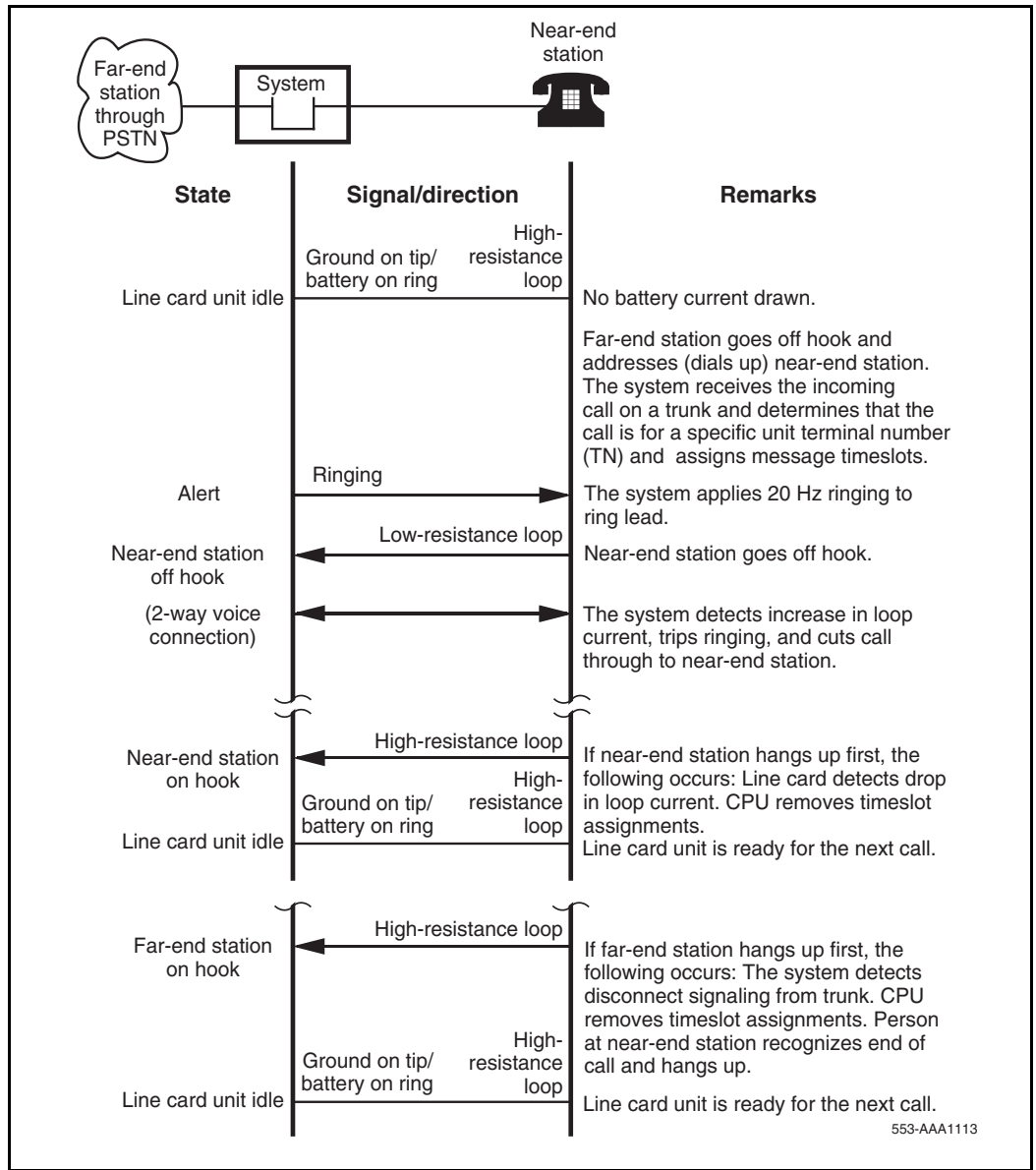
### Incoming calls

Incoming calls to a telephone that is connected to an analog line card can originate either from stations that are local (served by the PBX), or remote (served through the Public Switched Telephone Network (PSTN)). The alerting signal to a telephone is 20 Hz (nominal) ringing. When an incoming call is answered by the near-end station going off-hook, a low-resistance dc loop is placed across the tip and ring leads (towards the analog line card) and ringing is tripped. See Figure 6 on [page 43](#).

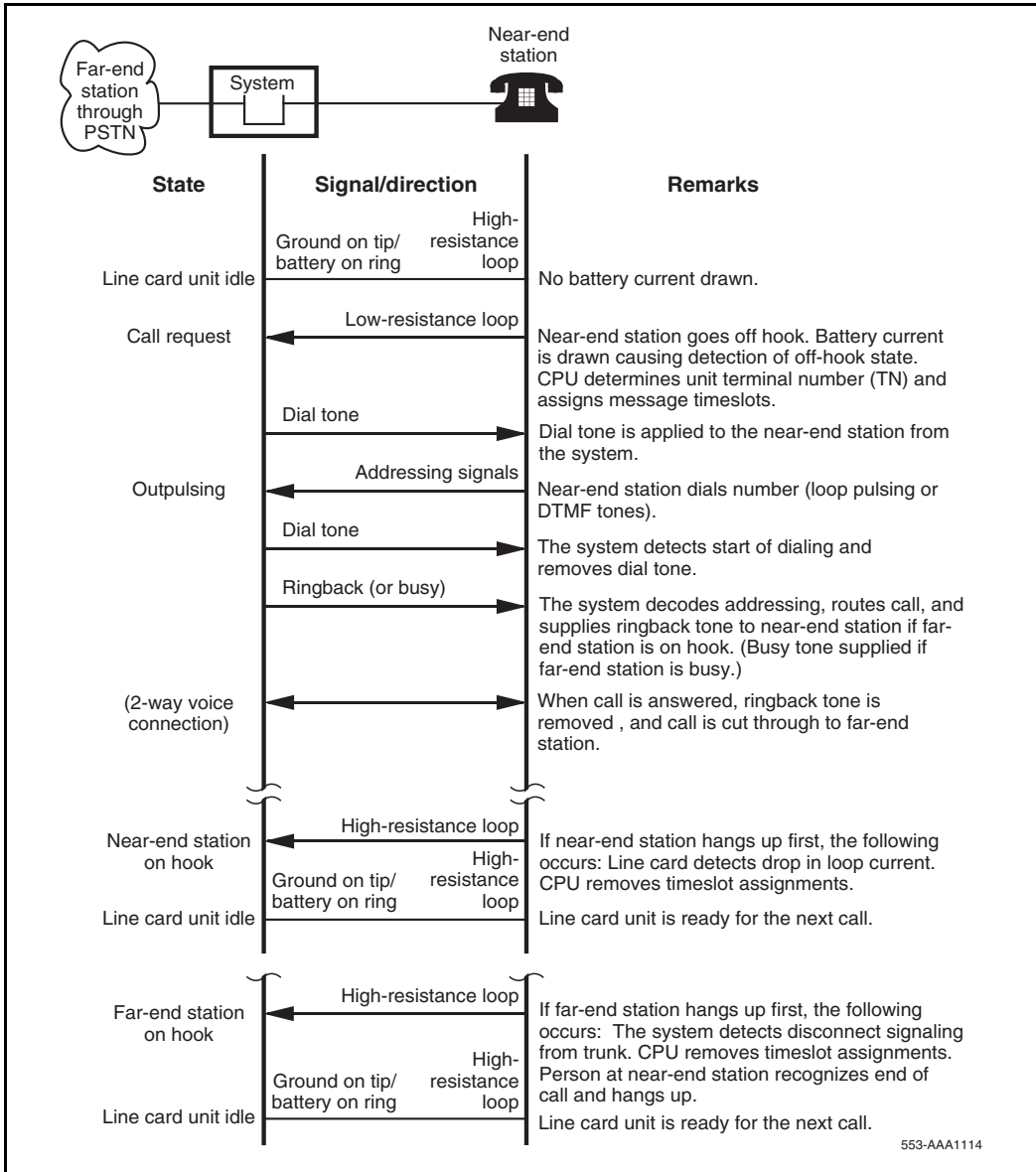
### Outgoing calls

For outgoing calls from the near-end station, a line interface unit is seized when the station goes off-hook, placing a low-resistance loop across the tip and ring leads towards the analog line card. See Figure 7 on [page 44](#). When the card detects the low-resistance loop, it prepares to receive digits. When the system is ready to receive digits, it returns dial tone. Outward address signaling is then applied from the near-end station in the form of loop (interrupting) dial pulses or DTMF tones.

**Figure 6**  
**Call connection sequence – near-end station receiving call**



**Figure 7**  
**Call connection sequence – near-end originating call**



## Message waiting

Line cards that are equipped with the message waiting feature receive notification that a message is waiting across the Card LAN link (IPE cards). On cards that drive a message waiting light, the light is turned on by connecting the ring side of the telephone line to the  $-150\text{ V}$  dc power supply. When the line card senses that the telephone has gone off-hook, it removes the  $-150\text{ V}$  dc voltage until the telephone goes back on-hook. Line cards that use an interrupted dial tone to indicate message waiting do nothing until the receiver is picked up. The line card then interrupts the dial tone at a regular interval to indicate that a message is waiting.

In both cases, the message waiting indication will continue until the user checks his or her messages. At that time, the system will cancel the message waiting indication by sending another message across the Card LAN link or network loop.

## Analog line supervision

Analog line supervision features are used to extend the answer supervision and disconnect supervision signals when the line card is connected to an intelligent terminal device (Key system or intelligent pay phone). Two types of analog line supervision are provided:

- battery reversal answer and disconnect supervision
- hook flash disconnect supervision

### ***Battery reversal answer and disconnect supervision***

Battery reversal answer and disconnect supervision is only used for calls that originate from the terminal device. It provides both far-end answer supervision and far-end disconnect supervision signals to the terminal device. In an intelligent pay phone application, these signals provide the information necessary to accurately compute toll charges.

In the idle state, and during dialing and ringing at the far end, the line card provides a ground signal on the tip lead and battery on the ring lead. See Figure 8 on [page 47](#). When the far-end answers, these polarities are reversed. The reversed battery connection is maintained as long as the call is established. When the far-end disconnects, the system sends a message that

causes the line card to revert the battery and ground signals to the normal state to signal that the call is complete.

### ***Hook Flash disconnect supervision***

Hook flash disconnect supervision is only used for incoming calls that terminate at the terminal device (typically a Key system). See Figure 9 on [page 48](#). The disconnect signal is indicated by the removal of the ground connection to the tip lead for a specific length of time. The length of time is programmed in LD10, and ranges from a minimum of 10 milliseconds to a maximum of 2.55 seconds. See *Software Input/Output: Administration* (553-3001-311) for more information.

## **Digital line call operation**

Digital line call operation is controlled entirely by use of messages between the digital telephone and the system. These messages are carried across the TCM loop interface. There is no call connection sequence similar to the one used for analog telephone line operation.

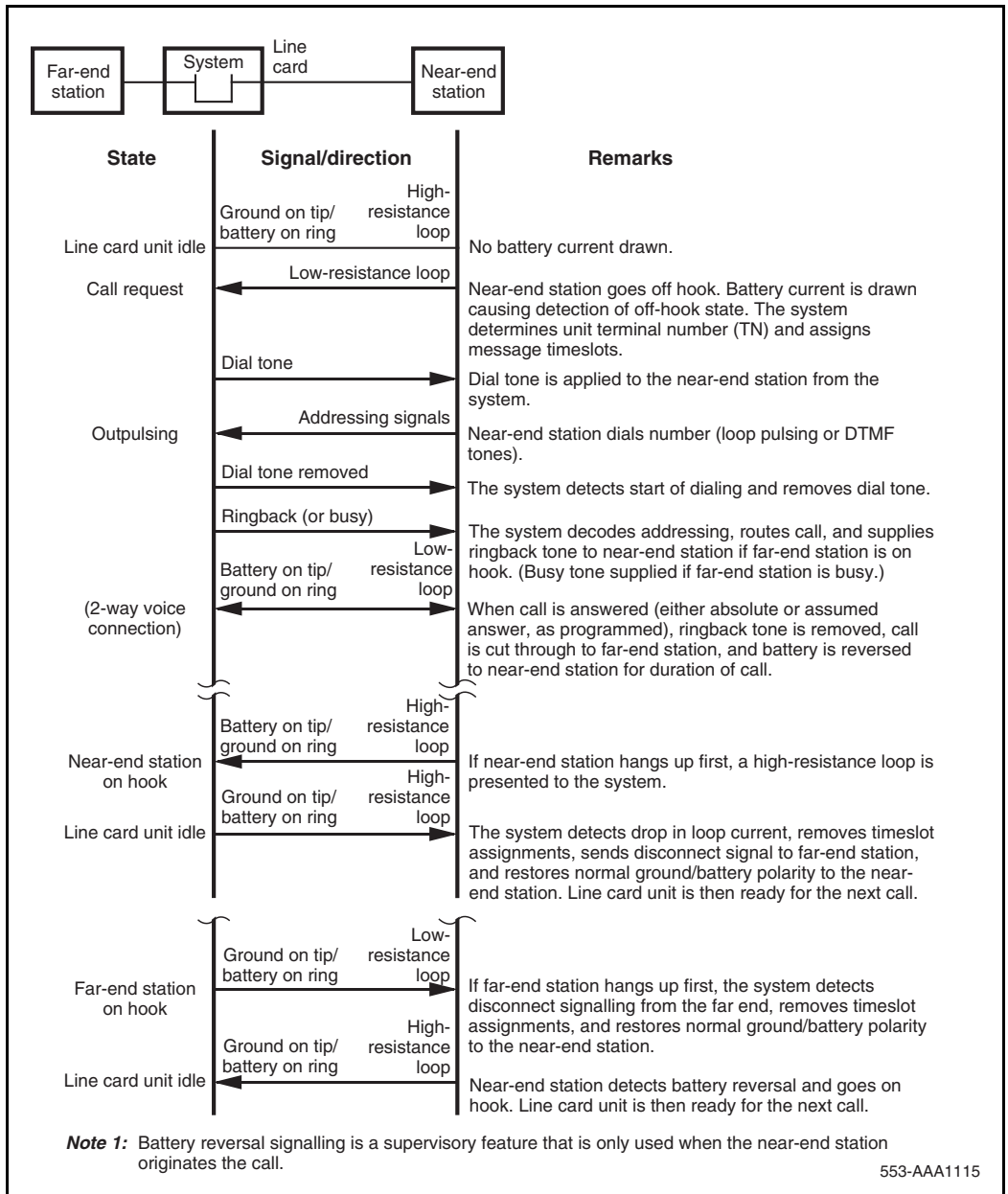
## **Lineside T1 call operation**

The lineside T1 card's call operation is performed differently depending on whether the T1 link is configured to process calls in loop start mode or ground start mode. Configuration is performed through dip switch settings on the lineside T1 card.

The lineside T1 card performs calls processing separately on each of its 24 channels. Signaling is performed using the "A/B robbed bit" signaling standard for T1 communication.

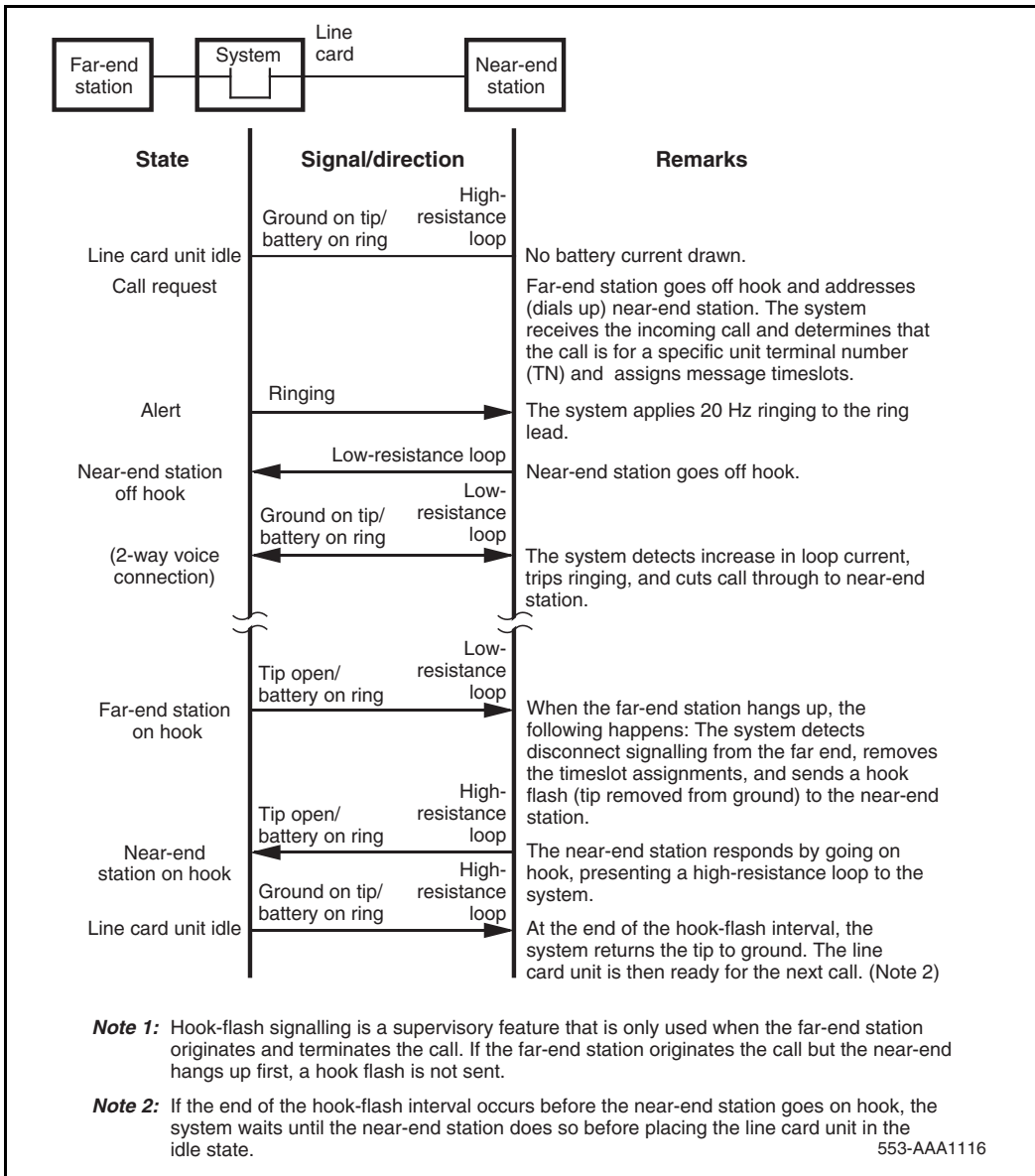
A/B robbed bit signaling simulates standard analog signaling by sending a meaningful combination of ones and zeros across the line that correlates to the electrical impulses that standard analog signaling sends. For example, to represent that an analog line interface unit is idle, the analog line card provides a ground on the tip lead and  $-48\text{Vdc}$  on the ring lead. The lineside T1 card accomplishes the same result by sending its A bit as 0 (translated as ground on the tip lead) and its B bit as 1 (translated as  $-48\text{V dc}$  on the ring lead). However, measuring the voltage of the ring lead on the T1 line would not return  $-48\text{V dc}$ , since actual electrical impulses are not being sent.

**Figure 8**  
**Battery reversal answer and disconnect supervision sequence**



553-AAA1115

**Figure 9**  
**Hook flash disconnect supervision sequence**





Call operation will be described by categorizing the operation into the following main states:

- Idle (on-hook)
- Incoming calls
- Outgoing calls
- Calls disconnected by the CO
- Calls disconnected by the telephone

### **Loop Start Mode**

In Loop Start mode, the A and B bits have the following meaning:

Transmit from LTI: A bit = 0 (tip ground on)

B bit = Ringing (0=on, 1=off)

Receive to LTI: A bit = Loop (0=open, 1=closed)

B bit = 1 (no ring ground)

When a T1 channel is idle, the lineside T1 card simulates a ground on the tip lead and  $-48\text{Vdc}$  on the ring lead to the terminal equipment by setting its transmit A bit to 0 and transmit B bit to 1. Accordingly, an on-hook channel on the terminal equipment simulates an open loop toward the lineside T1 card, causing the lineside T1 card's receive bits to be set to A = 0 and receive B = 1.

### ***Incoming calls***

Incoming calls to terminal equipment attached to the lineside T1 card can originate either from stations that are local (served by the PBX), or remote (served through the PSTN). To provide the ringing signal to a telephone the lineside T1 card simulates an additional 90V on the ring lead to the terminal equipment by alternating the transmit B bit between 0 and 1 (0 during ring on, 1 during ring off). When an incoming call is answered by the terminal equipment going off-hook, the terminal equipment simulates tripping the ringing and shutting off ringing, causing the lineside T1 card's receive A bit to be changed from 0 to 1.

### ***Outgoing calls***

During outgoing calls from the terminal equipment, a channel is seized when the station goes off-hook. This simulates a low-resistance loop across the tip and ring leads toward the lineside T1 card, causing the lineside T1's receive A bit to be changed from 0 to 1. This bit change prepares the lineside T1 to receive digits. Outward address signaling is then applied from the terminal equipment in the form of DTMF tones or loop (interrupting) dial pulses that are signaled by the receive A bit pulsing between 1 and 0.

### ***Call disconnect from far end (PSTN, private network or local Station)***

When a call is in process, the central office may disconnect the call from the CS 1000S, CS 1000M, and Meridian 1. If the lineside T1 port has been configured with the supervised analog line (SAL) feature, the lineside T1 card will respond to the distant end disconnect message by momentarily changing its transmit A bit to 1 and then returning it to 0. The duration of time that the transmit A bit remains at 1 before returning to 0 depends upon the setting that was configured using the SAL. If the terminal equipment is capable of detecting distant end disconnect, it will respond by changing the lineside T1 card's receive A bit to 0 (open loop). The call is now terminated and the interface is in the idle (on-hook) state.

For the lineside T1 card to support distant end disconnect in loop start mode, the following configuration parameters must exist:

- The Supervised Analog Line (SAL) feature must be configured for each lineside T1 port.

**Note:** By default, the SAL feature opens the tip side for 750 m/s in loop start operation. This is configurable in 10 m/s increments.

- For outgoing trunk calls, the trunk facility must provide far end disconnect supervision.
- In order to detect distant end disconnect for calls originating on the lineside T1 card, the battery reversal feature within the SAL software must be enabled. Enabling the battery reversal feature will not provide battery reversal indication but will only provide a momentary interruption of the tip ground by asserting the A bit to 1 for the specified duration.

- In order to detect distant end disconnect for calls terminating on the lineside T1 card, the hook flash feature within the SAL software must be enabled.
- In order to detect distant end disconnect for calls originating and terminating on the lineside T1 card, both the battery reversal and hook flash features must be enabled within the SAL software.

**Call disconnect from lineside T1 terminal equipment**

Alternatively, while a call is in process, the terminal equipment may disconnect by going on-hook. The terminal equipment detects no loop current and sends signaling to the lineside T1 card that causes its receive A bit to change from 1 to 0. The call is now released.

Table 4 outlines the lineside T1’s A and B bit settings in each state of call processing.

**Table 4**  
**Loop Start Call Processing A/B Bit Settings (Part 1 of 2)**

State	Transmit		Receive	
	A	B	A	B
Idle	0	1	0	1
<b>Incoming Calls:</b>				
• Idle	0	1	0	1
• Ringing is applied from lineside T1 card	0	1/0	0	1
• Terminal equipment goes off-hook	0	1/0	1	1
• Lineside T1 card stops ringing	0	1	1	1
<b>Outgoing Calls:</b>				
• Idle	0	1	0	1
• Terminal equipment goes off-hook	0	1	1	1
<b>Call Disconnect from far end:</b>				

**Table 4**  
**Loop Start Call Processing A/B Bit Settings (Part 2 of 2)**

State	Transmit		Receive	
	A	B	A	B
<ul style="list-style-type: none"> <li>Steady state (call in progress)</li> </ul>	0	1	1	1
<ul style="list-style-type: none"> <li>Far end disconnects by dropping loop current and lineside T1 card changes Transmit A bit to 1 momentarily.</li> </ul>	1	1	1	1
<ul style="list-style-type: none"> <li>Terminal equipment responds causing Receive A bit to change to 0.</li> </ul>	1	1	0	1
<ul style="list-style-type: none"> <li>Lineside T1 responds by changing its Transmit A bit to 0. Call is terminated and set to idle state.</li> </ul>	0	1	0	1
<b>Call disconnect from terminal equipment:</b>				
<ul style="list-style-type: none"> <li>Steady state (call in progress)</li> </ul>	0	1	1	1
<ul style="list-style-type: none"> <li>Terminal equipment goes on-hook causing the Receive A bit to change to 0. Call is terminated and set to idle state.</li> </ul>	0	1	0	1

**Ground Start Mode**

In ground start mode, the A and B bits have the following meaning:

Transmit from LTI: A bit = Tip ground (0=grounded, 1=not grounded)

B bit = Ringing (0=on, 1=off)

Receive to LTI: A bit = Loop (0=open, 1=closed)

B bit = Ring ground (0=grounded, 1=not grounded)

When a T1 channel is idle, the lineside T1 card simulates a ground on the tip lead and -48V dc on the ring lead to the terminal equipment by setting the transmit A bit to 1 and transmit B bit to 1. Accordingly, an on-hook telephone simulates an open loop toward the lineside T1 card, causing the lineside T1 card's receive bits to be set to A = 0 and B = 1.

### ***Incoming Calls***

Incoming calls to terminal equipment that is connected to the lineside T1 card can originate either from stations that are local (served by the PBX), or remote (served through the public switched telephone network). To provide the ringing signal to the terminal equipment the lineside T1 card simulates the 90V ring signal on the ring lead by alternating the transmit B bit between 0 and 1 (0 during ring on, 1 during ring off), and ground on the tip lead by setting the transmit A bit to 0. When an incoming call is answered (by the terminal equipment going off-hook), the terminal equipment simulates tripping the ringing and shutting off ringing by causing the lineside T1's receive A bit to change from 0 to 1. The lineside T1 card responds to this message by simulating loop closure by holding the transmit B bit constant at 1.

### ***Outgoing Calls***

During outgoing calls from the terminal equipment, a channel is seized when the terminal equipment goes off-hook, simulating a ground to the ring lead toward the lineside T1 card by causing the lineside T1's receive B bit to change from 1 to 0. In turn, the lineside T1 card simulates grounding its tip lead by changing the transmit A bit to 0. The terminal equipment responds to this message by removing the ring ground (lineside T1's receive B bit is changed to 1) and simulating open loop at the terminal equipment (lineside T1's receive A bit is changed to 0).

### ***Call disconnect from far end (PSTN, private network or local station)***

While a call is in process, the far end might disconnect the call. If the lineside T1 port has been configured with the Supervised Analog Line (SAL) feature, the lineside T1 will respond to the distant end disconnect message by opening tip ground. This causes the lineside T1 card to change the transmit A bit to 1. When the terminal equipment sees the transmit A bit go to 1, it responds by simulating open loop causing the lineside T1's receive A bit to change to 0. The call is terminated and the interface is once again in the idle condition.

For the lineside T1 card to support distant end disconnect in ground start mode, the following configuration parameters must exist:

- The Supervised Analog Line (SAL) feature must be configured for each lineside T1 port.

**Note:** By default, the SAL feature opens the tip side for 750 m/s in loop start operation. This is configurable in 10 m/s increments.

- In order to detect distant end disconnect for calls originating on the lineside T1 card, the “battery reversal” feature within the SAL software must be enabled. Enabling the “battery reversal” feature will not provide battery reversal indication when a call is answered; it will only provide battery reversal indication when a call is disconnected.
- In order to detect distant end disconnect for calls terminating on the lineside T1 card, the “hook flash” feature within the SAL software must be enabled.
- In order to detect distant end disconnect for calls originating and terminating on the lineside T1 card, both the “battery reversal” and “hook flash” features within the SAL software must be enabled.

***Call disconnect from lineside T1 terminal equipment***

Alternatively, while a call is in process, the terminal equipment may disconnect by going on-hook, causing the lineside T1’s receive A bit to change to 0. The lineside T1 card responds to this message by simulating the removal of ground from the tip by changing its transmit A bit to 1. The call is now terminated and the interface is once again in the idle condition.

Table 5 outlines the lineside T1’s A and B bit settings in each state of call processing.

**Table 5  
Ground Start Call Processing A/B Bit Settings (Part 1 of 2)**

State	Transmit		Receive	
	A	B	A	B
Idle	1	1	0	1
<b>Incoming Calls (to terminal equipment):</b>				
• Idle	1	1	0	1
• Ringing is applied from lineside T1 card by simulating ground on tip lead and ringing on ring lead.	0	0/1	0	1

**Table 5**  
**Ground Start Call Processing A/B Bit Settings (Part 2 of 2)**

State	Transmit		Receive	
	A	B	A	B
<ul style="list-style-type: none"> <li>Terminal equipment goes off-hook by simulating ground on tip lead and ringing on ring lead.</li> </ul>	0	0/1	1	1
<b>Outgoing Calls (from terminal equipment):</b>				
<ul style="list-style-type: none"> <li>Idle</li> </ul>	1	1	0	1
<ul style="list-style-type: none"> <li>Terminal equipment goes off-hook.</li> </ul>	1	1	0	0
<ul style="list-style-type: none"> <li>The lineside T1 simulates grounding its tip lead</li> </ul>	0	1	0	0
<ul style="list-style-type: none"> <li>Terminal equipment opens ring ground and closes loop</li> </ul>	0	1	1	1
<b>Call Disconnect from far end:</b>				
<ul style="list-style-type: none"> <li>Steady state (call in progress)</li> </ul>	0	1	1	1
<ul style="list-style-type: none"> <li>The lineside T1 ungrounds tip</li> </ul>	1	1	1	1
<ul style="list-style-type: none"> <li>Terminal equipment opens loop current</li> </ul>	1	1	0	1
<b>Call disconnect from terminal equipment:</b>				
<ul style="list-style-type: none"> <li>Steady state (call in progress)</li> </ul>	0	1	1	1
<ul style="list-style-type: none"> <li>Terminal equipment goes open loop current</li> </ul>	0	1	0	1
<ul style="list-style-type: none"> <li>Lineside T1 card opens tip ground</li> </ul>	1	1	0	1

### Ground Start Restrictions

If the lineside T1 card is used in ground start mode, certain restrictions should be considered. Because the system treats the lineside T1 card as a standard loop start analog line card, the ground start operation of the lineside T1 card has operational limitations compared to typical ground start interface equipment relating to *start of dialing*, *distant end disconnect* and *glare potential*.

### ***Distant end disconnect restrictions***

If the SAL feature is not available in the CS 1000 Release 4.5 software, the lineside T1 card is not capable of indicating to the Customer Premise Equipment (CPE) when a call has been terminated by the distant end. In this case, the lineside T1 card will continue to provide a grounded tip indication (A=0) to the CPE until it detects an open loop indication (A=0) from the CPE, at which time it will provide an open tip indication (A=1). Therefore, without SAL software, the lineside T1 card is not capable of initiating the termination of a call to the CPE.

With the SAL software configured for each lineside T1 line, the lineside T1 card will provide an open tip indication to the CPE when it receives an indication of supervised analog line from the system. This provides normal ground start protocol call termination.

### ***Glare restrictions***

In telephone lines or trunks, glare occurs when a call origination attempt results in the answering of a terminating call that is being presented by the far end simultaneously with the call origination attempt by the near end.

The lineside T1 detects presentation of a terminating call (outgoing to lineside T1 terminal equipment) by detecting ringing voltage. If application of the ringing voltage is delayed due to traffic volume and ringing generator capacity overload, the lineside T1 ground start operation cannot connect the tip side to ground to indicate the line has been seized by the system.

In ground start mode, glare conditions need to be considered if both incoming and outgoing calls to the Customer Premise Equipment (CPE) are going to be encountered. If the system and the CPE simultaneously attempt to use a lineside T1 line, the system will complete the call termination. It does not back down and allow the CPE to complete the call origination, as in normal ground start operation.

If both incoming and outgoing calls are to be handled through the lineside T1 interface, separate channels should be configured in the system and the CPE for each call direction. This eliminates the possibility of glare conditions on call origination.



## Voice frequency audio level

The digital pad for lineside T1 card audio level is fixed for all types of call connection (0 dB insertion loss in both directions), and differs from the analog line. Audio level adjustments, if required, must be made in the lineside T1 terminal equipment.

## Off-premise line protection

Off-premise applications are installations where the telephone lines are extended outside the building where the PBX system is housed, but the lines are not connected to public access facilities. This application is commonly referred to as a “campus installation.”

In off-premise applications, special protection devices and grounding are required to protect PBX and telephone components from any abnormal conditions, such as lightning strikes and power line crosses.

The NT1R20 Off-Premise Station Line card has built-in protection against lightning strikes and power line crosses. These should be the preferred cards for an off-premise application. Other cards can be used when external line protectors are installed.

When using the lineside T1 card for an off-premise or network application, external line protectors must be installed. Install an isolated type Channel Service Unit (CSU) as part of the terminal equipment, to provide the necessary isolation and outside line protection. The CSU should be an FCC part 68 or CSA certified unit.

## Line protectors

Line protectors are voltage-absorbing devices that are installed at the cross-connect terminals at both the main building and the remote building. The use of line protectors will ensure that system and telephone components are not damaged from accidental voltages that are within the limit of the capacity of the protection device. Absolute protection from lightning strikes and other stray voltages cannot be guaranteed, but the use of line protection devices significantly reduces the possibility of damage.

Nortel has tested line protection devices from three manufacturers. See Table 6. Each manufacturer offers devices for protection of digital as well as analog telephone lines.

**Table 6**  
**Line protection device ordering information**

Device order code		
Analog Line	Digital Line	Manufacturer
UP2S-235	UP2S-75	ITW Linx Communication 201 Scott Street Elk Grove Village, IL 60007 (708) 952-8844 or (800) 336-5469
6AP	6DP	Oneac Corporation 27944 North Bradley Road Libertyville, IL 60048-9700 (800) 553-7166 or (800) 327-8801 x555
ESP-200	ESP-050	EDCO Inc. of Florida 1805 N.E. 19th Avenue P.O. Box 1778 Ocala, FL 34478 (904) 732-3029 or (800) 648-4076

These devices are compatible with 66 type M1-50 split blocks or equivalent. Consult the device manufacturer if more specific compatibility information is required.

### Line protection grounding

In conjunction with line protectors, proper system (PBX) grounding is essential to minimize equipment damage. Nortel recommends following the

grounding connection requirements as described in *System installation* (553-3001-210). This requirement includes connecting the ground for the protection devices to the approved building earth ground reference. Any variances to these grounding requirements could limit the functionality of the protection device.

## Line and telephone components

Because testing of the line protectors was limited to the line cards and telephones shown below, only these components should be used for off-premise installations.

### Telephones

- Meridian Modular Telephones (digital)
- Meridian Digital Telephones
- Standard analog (500/2500-type) telephones

### Line cards

- NT1R20 Off-Premise Station Line card
- NT8D02 Digital Line card
- NT8D03 Analog Line card

## Trunk cards

The following trunk cards are designed using the IPE architecture, and are recommended for use in all new system designs.

Each of the trunk cards was designed to fit a specific system need. Use Table 7 to help select the trunk card that will best meet system needs.

**Table 7**  
**Trunk card characteristics**

Part Number	Description	Trunks	Trunk Types	Architecture
NT8D14	Universal Trunk card	8	CO/FX/WATS trunks*, direct inward dial trunks, TIE trunks, Loop Dial Repeating trunks Recorded Announcement trunks, Paging trunks	IPE
NT8D15	E&M Trunk card	4	2-wire E&M trunks, 4-wire E&M trunks, 4-wire DX trunks, Paging trunks	IPE
NTCK16	Generic Central Office Trunk card	8	CO trunks	IPE

\* Central office (CO), Foreign Exchange (FX), and Wide Area Telephone Service (WATS) trunks.

**NT8D14 Universal Trunk card**

The NT8D14 Universal Trunk card is an intelligent four-channel trunk card that is designed to be used in a variety of applications. It supports the following five trunk types:

- Central office (CO), Foreign Exchange (FEX), and Wide Area Telephone Service (WATS) trunks
- Direct Inward Dial (DID) trunks
- TIE trunks: two-way Loop Dial Repeating (LDR) and two-way loop Outgoing Automatic Incoming Dial (OAID)
- Recorded Announcement (RAN) trunks
- Paging (PAG) trunks

The universal trunk card also supports Music, Automatic Wake Up, and Direct Inward System Access (DISA) features.

### **NT8D15 E&M Trunk card**

The NT8D15 E&M Trunk card is an intelligent four-channel trunk card that is designed to be used when connecting to the following types of trunks:

- 2-wire E&M Type I signaling trunks
- 4-wire E&M trunks with:
  - Type I or Type II signaling
  - Duplex (DX) signaling
- Paging (PAG) trunks

The trunk type and function can be configured on a per port basis. Dialing outpulsing is provided on the card. Make and break ratios are defined in software and downloaded by software commands.

### **NTCK16 Generic Central Office Trunk card**

The NTCK16 generic central office trunk cards support up to eight analog central office trunks. They can be installed in any IPE slot that supports IPE. The cards are available with or without the Periodic Pulse Metering (PPM) feature. The cards are also available in numerous countries.

## **Installation**

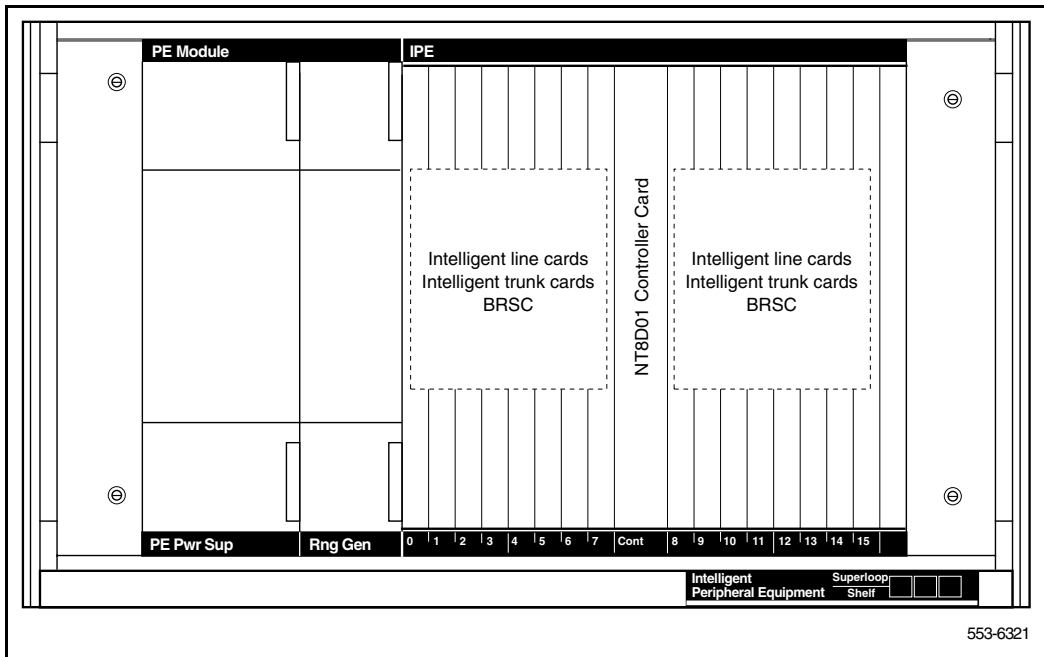
This section provides a high-level description of how to install and test trunk cards.

IPE trunk cards can be installed in any IPE slot of the NT8D37 IPE module. Figure 10 on [page 62](#) shows where an IPE trunk card can be installed in an NT8D37 IPE module.

When installing trunk cards, these general procedures should be used:

- 1** Configure the jumpers and switches on the trunk card (if any) to meet the system needs.
- 2** Install the trunk card into the selected slot.

**Figure 10**  
**IPE trunk cards installed in an NT8D37 IPE module**



- 3 Install the cable that connects the backplane connector on the IPE module to the module I/O panel.
- 4 Connect a 25-pair cable from the module I/O panel connector to the Main Distribution Frame (MDF).
- 5 Connect the trunk card output to the selected terminal equipment at the MDF.
- 6 Configure the individual trunk interface unit using the Trunk Administration program (LD 14) and the Trunk Route Administration program (LD 16).

Once these steps have been completed, the trunk card is ready for use.

## Operation

This section describes how trunk cards fit into the CS 1000S, CS 1000M, and Meridian 1 architecture, the buses that carry signals to and from the trunk cards, and how they connect to terminal equipment. See Table 8 for IPE parameters.

### Host interface bus

Cards based on the IPE bus have a built-in microcontroller. The IPE microcontroller is used for the following:

- to perform local diagnostics (self-test)
- to configure the card according to instructions issued by the system processor
- to report back to the system processor information such as card identification (type, vintage, and serial number), firmware version, and programmed configuration status.

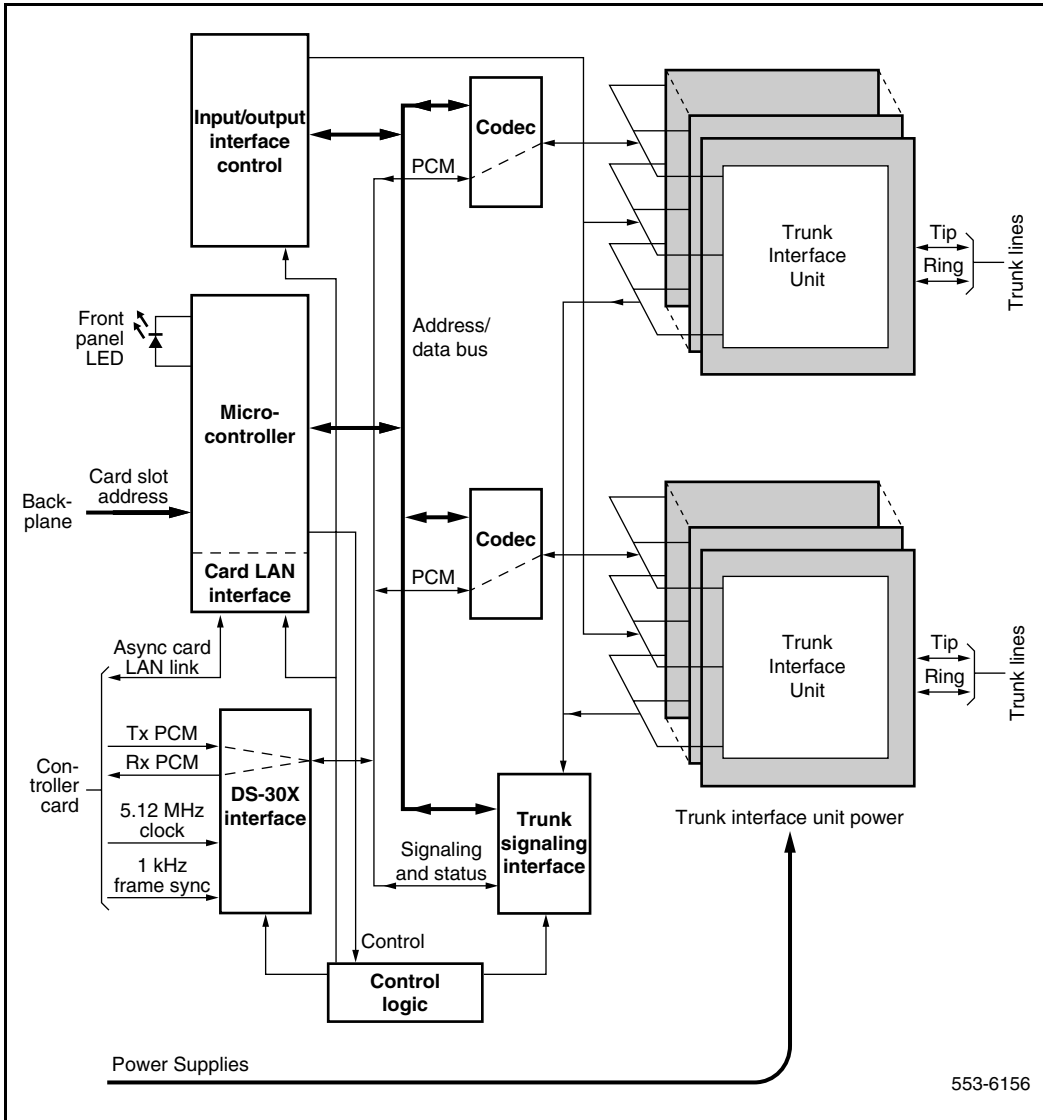
**Table 8**  
**Differences between IPE parameters**

Parameter	IPE
Card Dimensions	31.75 x 25.4 x 2.2 cm. (12.5 x 10.0 x 0.875 in.)
Network Interface	DS-30X Loops
Communication Interface	card LAN Link
Microcontroller	8031
Peripheral Interface card	NT8D01 Controller card
Network Interface card	NT8D04 Superloop Network card
Modules	NT8D37 IPE module

### Intelligent Peripheral Equipment

IPE trunk cards all have a similar architecture. Figure 11 on [page 64](#) shows a typical IPE trunk card architecture. The various trunk cards differ only in the number and types of trunk interface units.

Figure 11  
Typical IPE trunk card architecture





The switch communicates with IPE modules over two separate interfaces. Voice and signaling data are sent and received over DS-30X loops and maintenance data is sent over a separate asynchronous communication link called the card LAN link.

Signaling data is information directly related to the operation of the telephone line. Some examples of signaling commands are as follows:

- off hook/on hook
- ringing signal on/off
- message waiting lamp on/off

Maintenance data is data relating to the configuration and operation of the IPE card, and is carried on the card LAN link. Some examples of maintenance data are as follows:

- polling
- reporting of self-test status
- CPU initiated card reset
- reporting of card ID (card type and hardware vintage)
- reporting of firmware version
- downloading trunk interface unit configuration
- reporting of trunk interface unit configuration
- enabling/disabling of the DS-30X network loop bus
- reporting of card status

### ***DS-30X loops***

The interfaces provided by the line and trunk cards connect to conventional 2-wire (tip and ring) line facilities. IPE analog line and trunk cards convert the incoming analog voice and signaling information to digital form, and route it to the Common Equipment (CE) CPU over DS-30X network loops. Conversely, digital voice and signaling information from the CPU is sent over DS-30X network loops to the analog line and trunk cards where it is converted to analog form and applied to the line or trunk facility.

IPE digital line cards receive the data from the digital phone terminal as 512 kHz Time Compressed Multiplexed (TCM) data. The digital line card converts that data to a format compatible with the DS-30X loop, and transmits it in the next available timeslot. When a word is received from the DS-30X loop, the digital line card converts it to the TCM format and transmits it to the digital phone terminal over the digital line facility.

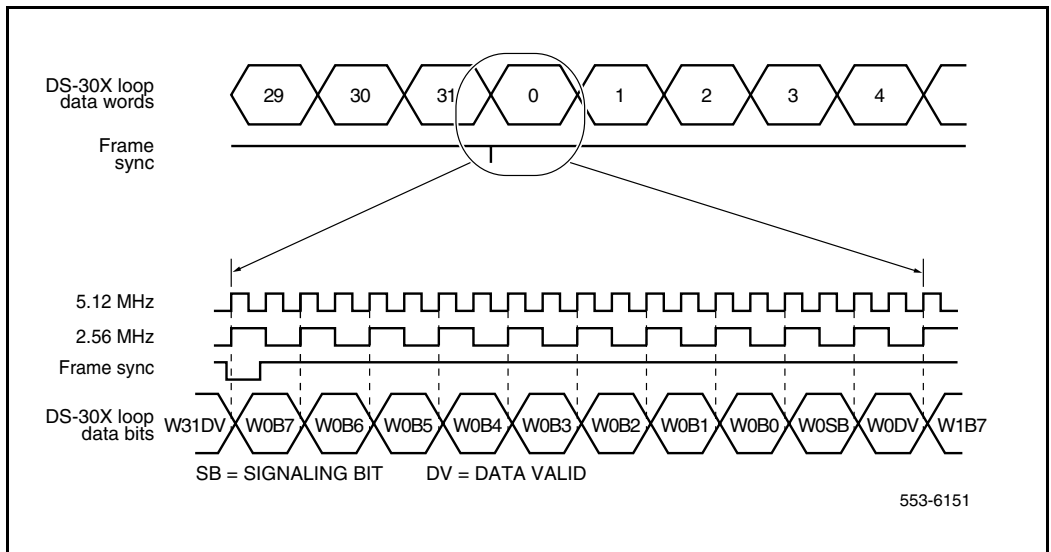
A separate dedicated DS-30X network loop is extended between each IPE line/trunk card and the controller cards within an IPE module (or the controller circuits on a network/DTR card in a CE module). A DS-30X network loop is composed of two synchronous serial data buses. One bus transports in the transmit (Tx) direction toward the line facility and the other in the receive (Rx) direction toward the common equipment.

Each bus has 32 channels for pulse code modulated (PCM) voice data. Each channel consists of a 10-bit word. See Figure 12 on [page 67](#).

Eight of the 10 bits are for PCM data, one bit is the call signaling bit, and the last bit is a data valid bit. The 8-bit PCM portion of a channel is called a *timeslot*. The DS-30X loop is clocked at 2.56 Mbps (one-half the 5.12 MHz clock frequency supplied by the controller card). Thus, the timeslot repetition rate for a single channel is 8 kHz. The controller card also supplies a locally generated 1 kHz frame sync signal for channel synchronization.

Signaling data is transmitted to and from the line cards using the call signaling bit within the 10-bit channel. When the line card detects a condition that the switch needs to know about, it creates a 24-bit signaling word. This word is shifted out on the signaling bit for the associated channel one bit at a time during 24 successive DS-30X frames. Conversely, when the switch sends

**Figure 12**  
**DS-30X loop data format**



signaling data to the line card, it is sent as a 24-bit word divided among 24 successive DS-30X frames.

DS-30Y network loops extend between controller cards and superloop network cards in the common equipment, and function in a manner similar to DS-30X loops. See Figure 13 on [page 68](#).

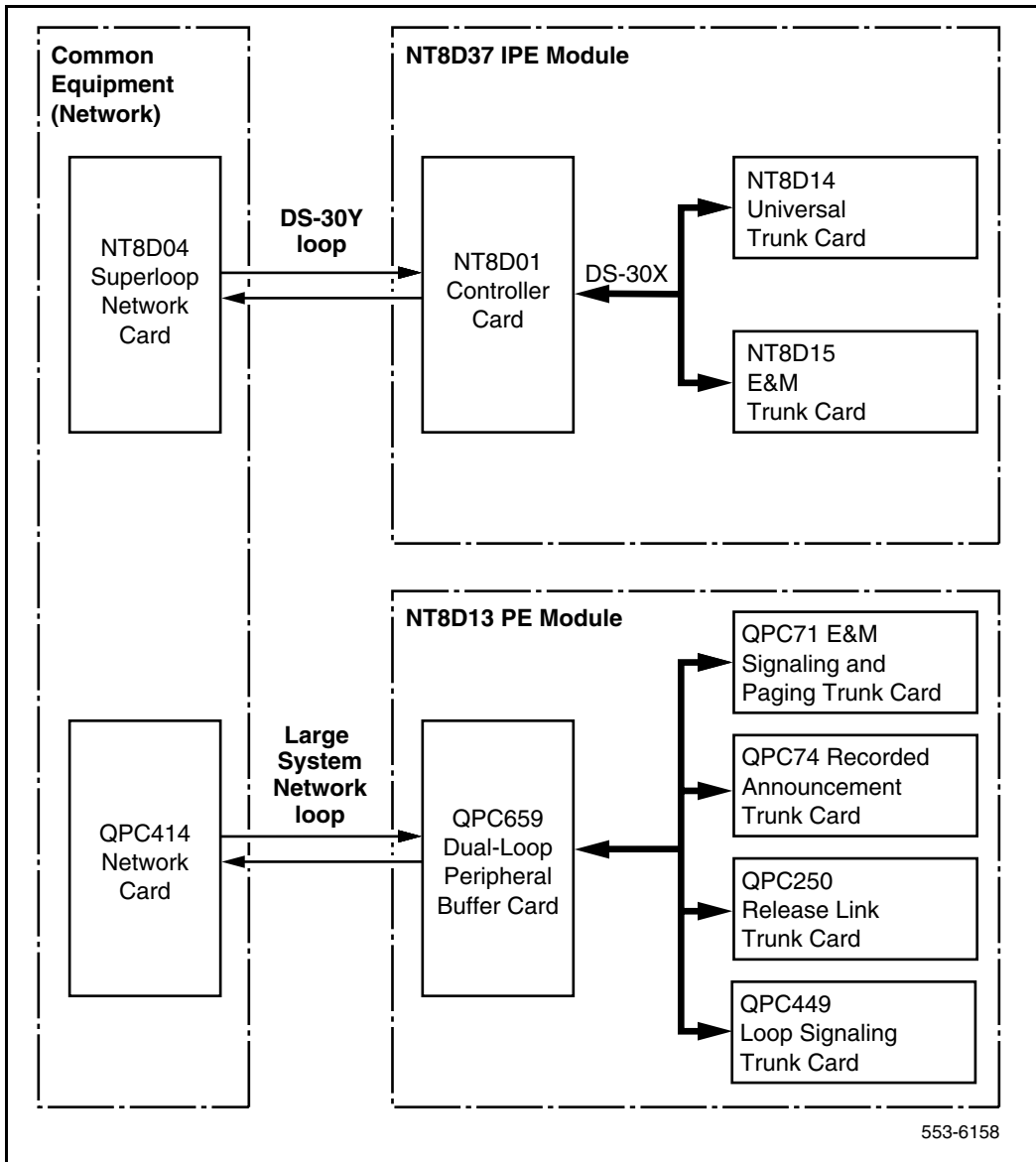
Essentially, a DS-30Y loop carries the PCM timeslot traffic of a DS-30X loop. Four DS-30Y network loops form a *superloop* with a capacity of 128 channels (120 usable timeslots).

See *Communication Server 1000M and Meridian 1: Large System Planning and Engineering* (553-3021-120) for more information on superloops.

### **Card LAN link**

Maintenance communication is the exchange of control and status data between IPE line or trunk cards and the CE CPU by way of the NT8D01 Controller Card. Maintenance data is transported via the *card LAN* link. This

Figure 13  
Network connections to IPE modules



link is composed of two asynchronous serial buses (called the Async card LAN link in Figure 11 on [page 64](#)). The output bus is used by the controller for output of control data to the trunk card. The input bus is used by the controller for input of trunk card status data.

A card LAN link bus is common to all of the line/trunk card slots within an IPE module (or IPE section of a CE module). This bus is arranged in a master/slave configuration where the controller card is the master and all other cards are slaves. The module backplane provides each line/trunk card slot with a unique hardwired slot address. This slot address enables a slave card to respond when addressed by the controller card. The controller card communicates with only one slave at a time.

In normal operation, the controller card continually scans (polls) all of the slave cards connected to the card LAN to monitor their presence and operational status. The slave card sends replies to the controller on the input bus along with its card slot address for identification. In this reply, the slave informs the controller if any change in card status has taken place. The controller can then prompt the slave for specific information. Slaves only respond when prompted by the controller; they do not initiate exchange of control or status data on their own.

When an IPE line or trunk card is first plugged into the backplane, it runs a self-test. When the self test is completed, a properly functioning card responds to the next controller card poll with the self-test status. The controller then queries for card identification and other status information. The controller then downloads all applicable configuration data to the line/trunk card, initializes it, and puts it into an operational mode.

The network card regularly polls the IPE cards during TSO to see if any of them has a message to be sent. When an IPE card has a message waiting it responds to the poll by sending a series of 1s during the next five successive timeslot 0s. The network card responds by sending a “message send enable” message (all 1s). The IPE card replies by sending 1, 1, 1, 0, and then the message in successive timeslot 0s.

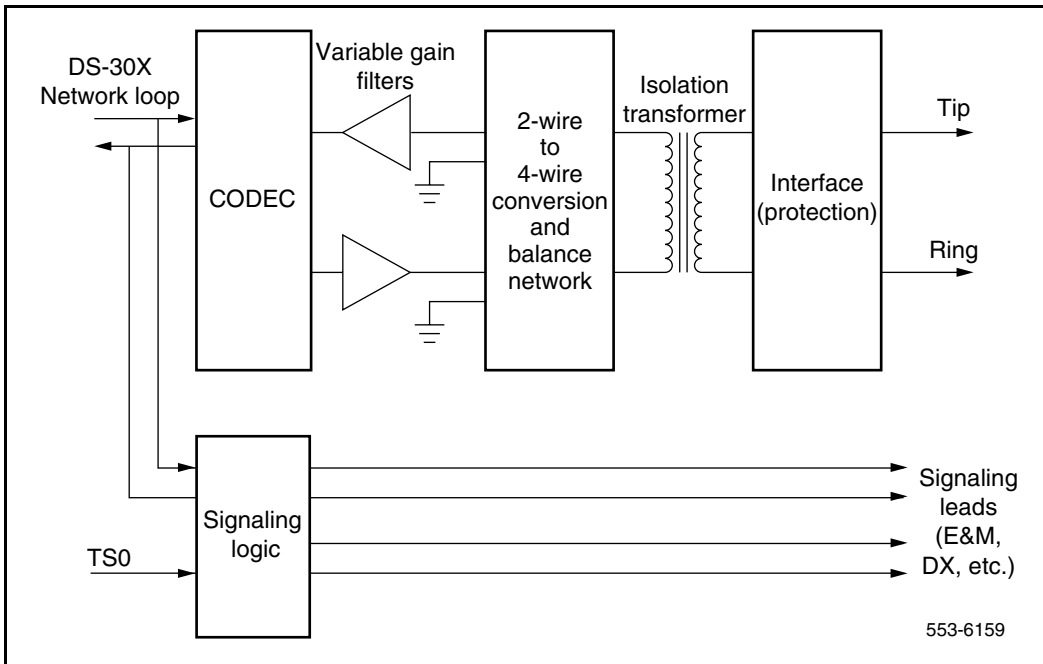
## Trunk interface unit

Once the 8-bit digital voice signal has been received by the trunk card, it must be converted back into an analog signal, filtered, and driven onto the analog

trunk line through an impedance matching and balance network. The trunk interface also includes the logic necessary to place outgoing call signaling onto the trunk, or the logic to connect to special services such as recorded announcement and paging equipment.

Figure 14 shows a typical example of the logic that performs these functions. Each part of the trunk interface unit is discussed in the following section.

**Figure 14**  
**Typical trunk interface unit block diagram**



**Coder/Decoder circuit**

The coder/decoder (codec) performs Analog to Digital (A/D) and Digital to Analog (D/A) conversion of the line analog voiceband signal to and from a digital PCM signal. This signal can be coded and decoded using either the A-Law or the  $\mu$ -Law companding algorithm. On some trunk cards the decoding algorithm depends of the type of codec installed when the board is built. On others, it is an option selected using a software overlay.

### ***Variable gain filters***

Audio signals received from the analog phone trunk are passed through a low-pass A/D monolithic filter that limits the frequency spread of the input signal to a nominal 200–3400 Hz bandwidth. The audio signal is then applied to the input of the codec. Audio signals coming from the CODEC are passed through a low-pass A/D monolithic filter that integrates the amplitude modulated pulses coming from the CODEC, and then filters and amplifies the result.

On some of the trunk cards, the gain of these filters can be programmed by the system controller. This allows the system to make up for line losses according to the loss plan.

### ***Balancing network***

Depending on the card type, the balancing network is capable of providing either a 600 ohm or a 900 ohm (or both) impedance matching network. It also converts the 2-wire transmission path (tip and ring) to a 4-wire transmission path (Rx/ground and Tx/ground). The balancing network is a transformer/ analog (hybrid) circuit combination.

### ***Signaling circuits***

Signaling circuits are relays that place outgoing call signaling onto the trunk. Signal detection circuits monitor the incoming call signaling.

### ***Control signals***

Control signals and logic are provided when the trunk is going to be connected to special services such as recorded announcement and paging equipment.

## Serial Data Interface (SDI) cards

The NT8D41BA QSDI paddle board provides four bidirectional asynchronous serial ports for the system processor, and the QPC841 QSDI card also provides four. Any device that conforms to the RS-232-C serial communication standard can be connected to these serial ports.

The QPC513 ESDI card provides two fully synchronous serial ports for the system processor. The ESDI card communicates using the Link Access Procedure Balanced (LAP-B) synchronous communication protocol.

The electrical interface uses either standard RS-232-C signals or a special high-speed interface that combines the high-speed differential interface of the RS-422-A standard with the handshake signals of the RS-232-C standard.

The RS-232-C interface is normally used when data rates are less than 19.2 Kbps, and the cable length is less than 15.24 m (50 ft). The high-speed interface is used when the signal rates are greater than 19.2 kbps (up to 64 kbps) and/or when the cable length is greater than 15.24 m (50 ft).

Table 9 shows compatibility between the three SDI cards and the various switch options.

**Table 9**  
**Serial data interface cards**

Card	Ports	Port types	Compatible System Options	
			51C, 61C	81C
NT8D41BA	4	RS-232-C asynchronous	X	X
QPC841	4	RS-232-C asynchronous	X	X
QPC513	2	RS-232-C synchronous or high-speed synchronous*	X	X
*See the section on the QPC513 card in this manual for details on the high-speed interface				

The NT8D41BA QSDI paddle board does not have a front panel. It mounts to the rear of the backplane in the NT5D21 Core/Network module, and does



not consume a module slot. The RS-232-C connections are brought out through special cables to the backplane I/O panel.

The QPC841 Quad SDI card and the QPC513 Enhanced SDI card mount in standard backplane slots, and their serial interface connectors are located on the card front panels. A list of the modules that they can be mounted in is given in the following sections on the individual cards.

## Uses

Examples of asynchronous devices that can be connected to the system processor using the NT8D41BA QSDI paddle board and the QPC841 Quad SDI card are:

- an administration and maintenance terminal
- a background terminal for use in a hotel/motel
- the Automatic Call Distribution (ACD) feature
- the Call Detail Recording (CDR) feature

Examples of synchronous devices that can be connected to the system processor using the QPC513 Enhanced SDI card are:

- a host computer (DEC, Tandem, for example) using the Meridian Link communication program
- the Meridian Mail voice-mail option

## Features

The NT8D41 QSDI paddle board and the QPC841 QSDI card provide the following features:

- asynchronous serial data interface ports, each supporting
  - RS-232-C interface
  - 8-bit ASCII data with parity and stop bit
  - Asynchronous, start-stop operation
  - Data rates of 150, 300, 600, 1200, 2400, 4800, and 9600 baud

- Data terminal equipment (DTE) emulation mode
- Data communication equipment (DCE) emulation mode
- enable/disable switch and LED
- input/output (I/O) device address selectable by on-board switches.

The QPC513 ESDI card provides these features:

- fully synchronous serial data interface ports, each supporting
  - RS-232-C or modified RS-422-A interface
  - LAPB subset of the HDLC synchronous protocol
  - Data rates of 1200, 2400, 4800, 9600, 19200, 48000, 56000, and 64000 baud
  - Data terminal equipment (DTE) emulation mode
  - Data communication equipment (DCE) emulation mode
- enable/disable switch and LED
- input/output (I/O) device address selectable by on-board switches.

## Specifications

This section lists the specifications shared by all of the SDI cards. See the appropriate section in this document for information specific to any particular card.

## Power consumption

The SDI cards obtain their power directly from the module backplane. Power consumption for each of the cards is shown in Table 10.

**Table 10**  
**Power consumption**

Voltage	Maximum power consumption		
	NT8D41BA	QPC513	QPC841
+5 VDC $\pm 5\%$	1.0 Amp	3.0 Amp	1.5 Amp
+12 VDC $\pm 5\%$	100 mA	50 mA	100 mA
-12 VDC $\pm 5\%$	100 mA	50 mA	100 mA

## Environmental

The SDI cards operate without degradation under the conditions listed in Table 11.

**Table 11**  
**Environmental specifications**

Specification	Operation	Storage
Ambient temperature	0° to 50°C; (32° to 122°F)	-55° to +70°C; (-58° to 158°F)
Relative humidity (non-condensing)	5% to 95%	0% to 95%
Altitude	3500m; (11000 ft)	15000m; (50000 ft)

## Electrostatic discharge

The SDI cards meet the requirements of the IEC 801-2, clause 8.0 procedure. They can withstand a direct discharge of  $\pm 5$  to  $\pm 20$  kV without being damaged.

### **Electromagnetic interference**

The CS 1000S, CS 1000M, and Meridian 1 systems meet the requirements of FCC Part 15 and CSA C108.8 electromagnetic interference (EMI) standards as a class “A” computing device. To accomplish this, the SDI cables must exit the module through EMI filters on the I/O panel.

### **Reliability**

The Mean Time Between Failure (MTBF) for all SDI cards is 55 years at 40°C and 29 years at 55°C.

## **Installation**

To use a serial data interface card in a CS 1000S, CS 1000M, or Meridian 1 system, first install the card in the system, and then configure the system software to recognize it. These steps are discussed in the following sections.

Instructions for cabling the serial data interface cards to the various system consoles and peripherals are found in *Communication Server 1000M and Meridian 1: Large System Installation and Configuration* (553-3021-210).

### **Configuring the system software**

Once an SDI card has been installed in the system, the system software needs to be configured to recognize it. This is done using the Configuration Record program LD 17. Instructions for the Configuration Record program are found in *Software Input/Output: Administration* (553-3001-311).

## **Maintenance**

The following maintenance programs are used to maintain individual SDI asynchronous ports. The program used depends on the application of the port.

- LD 37 Input/Output Diagnostics – Used for system terminal, printer, background terminal ports, and system monitor status.
- LD 42 Call Detail Recording (CDR) Diagnostic – For checking CDR links and CDR system terminals.

The following maintenance program is used to maintain individual SDI synchronous ports.

- LD 48 Link Diagnostic – For checking Automatic Call Distribution (ACD) and Meridian Link ports.

Instructions for running the various maintenance programs are found in *Software Input/Output: Administration* (553-3001-311). System messages are interpreted in *Software Input/Output: System Messages* (553-3001-411).



---

# Circuit card installation

---

## Contents

This section contains information on the following topics:

Card slots — Large System . . . . .	79
Circuit card installation . . . . .	80
Precautions . . . . .	84
Installing a circuit card . . . . .	86

## Card slots — Large System

The following table in this chapter identifies card slot compatibility in the following modules:

- NT4N41 Core/Network module required for CS 1000M SG, CS 1000M MG, Meridian 1 PBX 61C Call Processor (CP) PII, CP PIV, and Meridian 1 PBX 81C
- NT4N46 Core/Network module required for CS 1000M MG and Option 81C CP PII, CP PIV
- NT6D60 Core/Network module required for the CS 1000M MG and Option 81C only
- NT8D35 Network module required for CS 1000M MG and Meridian 1 PBX 81C
- NT8D37 Intelligent Peripheral Equipment (IPE) module required for CS 1000M HG, CS 1000M SG, CS 1000M MG, Meridian 1 Option 51, Meridian 1 PBX 61C, and Meridian 1 PBX 81C

## Circuit card installation

**Table 12**  
**Large System card slots (Part 1 of 4)**

Component	Large System
A0786611 Call Processor Pentium II® card	81C Core/Net: "CP"
A0810486 Call Processor Pentium II	81C Core/Net: "CP"
NT1P61 Fiber Superloop Network card	Core/Net: 0–7
NT1P62 Fiber Peripheral Controller card	IPE: "Contr"
NT1R52 Remote Carrier Interface	IPE: "Contr"
NT1R20 Off-Premise Station	IPE: any slot but "Contr"
NT4D18 Hybrid Bus Terminator	Core/Net: between 11 and 12
NT4D19 and NT423 Hybrid Bus Terminator	Core/Net: between 0 and 1
NT4D20 and NT422 Hybrid Bus Terminator	Core/Net: between 1 and 2
NT4N43 Multi-Medium Disk Unit	81C Core/Net:
NT4N64 Call Processor Pentium II card	61C Core/Net: CP PII
NT4N64 Call Processor Pentium II card	81C Core/Net: CP PII
NT4N39 Call Processor Pentium IV card	61C Core/Net: CP PIV
NT4N39 Call Processor Pentium IV card	81C Core/Net: CP PIV
NT4N65 cPCI® Core to Network Interface card	81C Core/Net: c9–c12
NT4N66 cPCI Core to Network Interface Transition card	81C Core/Net cPCI Core backplane: 9–12
NT4N67 System Utility card	81C Core/Net: c15
NT4N68 System Utility Transition card	81C Core/Net cPCI Core backplane:
NT5D11 and NT5D14 Line side T1 Line card	IPE: any slot but "Contr"
NT5D12AA Dual DTI/PRI card	Core/Net: 0–7
NT5D61 Input/Output Disk Unit with CD-ROM (MMDU)	61C Core/Net: 17, 18 and 19



**Table 12**  
**Large System card slots (Part 2 of 4)**

<b>Component</b>	<b>Large System</b>
NT5K02 Analog Line card	IPE: any slot but "Contr"
NT5K07 Universal Trunk card	IPE: any slot but "Contr"
NT5K17 Direct Dial Inward Trunk card	IPE: any slot but "Contr"
NT5K18 Central Office Trunk card	IPE: any slot but "Contr"
NT5K19 E&M Trunk card	IPE: any slot but "Contr"
NT5K35 D-channel Handler Interface	Core/Net: 0-7 Net: 5-12
NT5K36 Direct Inward/Direct Outward Dial Trunk card	IPE: any slot but "Contr"
NT5K70 Central Office Trunk card	IPE: any slot but "Contr"
NT5K71 Central Office Trunk card	IPE: any slot but "Contr"
NT5K72 E&M Trunk card	IPE: any slot but "Contr"
NT5K82 Central Office Trunk card	IPE: any slot but "Contr"
NT5K83 E&M Trunk card	IPE: any slot but "Contr"
NT5K84 Direct Inward Dial Trunk card	IPE: any slot but "Contr"
NT5K90 Central Office Trunk card	IPE: any slot but "Contr"
NT5K93 Central Office Trunk card	IPE: any slot but "Contr"
NT5K96 Analog Line card	IPE: any slot but "Contr"
NT5K99 Central Office Trunk card	IPE: any slot but "Contr"
NT5K20 Extended Tone Detector	IPE: any slot but "Contr"
NT6D65 Core to Network Interface	61C Core/Net: 12
NT6D66 Call Processor card	61C Core/Net: 15 and 16
NT6D70 S/T Interface Line card	IPE: any slot but "Contr"

**Table 12**  
**Large System card slots (Part 3 of 4)**

Component	Large System
NT6D71 U Interface Line card	IPE: any slot but "Contr"
NT6D72 Basic Rate Signal Concentrator card	IPE: any slot but "Contr"
NT6D73 Multi-purpose ISDN Signaling Processor card	Core/Net: 0–7
NT6D80 MSDL	Core/Net: 0–7
NT7D16 Data Access card	IPE: any slot but "Contr"
NT7R51 Local Carrier Interface	Core/Net: 0–7
NT8D01 Controller card	IPE: "Contr"
NT8D02 Digital Line card	IPE: any slot but "Contr"
NT8D04 Superloop Network card	Core/Net: 0–7 Net: 5-12
NT8D09 Analog Message Waiting Line card	IPE: any slot but "Contr"
NT8D14 Universal Trunk card	IPE: any slot but "Contr"
NT8D15 E&M Trunk card	IPE: any slot but "Contr"
NT8D16 Digitone Receiver card	IPE: any slot but "Contr"
NT8D17 Conference/TDS card	Core/Net: 0–7
NT8D41 Dual Port Serial Data Interface card	Serial Port back of Core/Net module
NT9D19 Call Processor card	61C Core/Net: 15 and 16
NTAG03 Central Office Trunk card	IPE: any slot but "Contr"
NTAG04 Central Office/Direct Inward Dial Trunk card	IPE: any slot but "Contr"
NTAG36 Nortel Integrated Recorded Announcer	IPE: any slot but "Contr"
NTBK51 Downloadable D-channel daughterboard	Connects to DDP card
NTCK16 Generic Central Office Trunk card	IPE: any slot but "Contr"

**Table 12**  
**Large System card slots (Part 4 of 4)**

<b>Component</b>	<b>Large System</b>
NTCK43AA Primary Rate Interface card	Core/Net: 0-7 Net: 5-11, 13-14
NTRB33 Fiber Junctor Interface card	For 81C: Core/Net: 8 and 9, Net module: 2 and 3
NTRE39 Optical Cable Management card	For 81C: Net module: the slot to the right side of 14, the slot to the left of the 3PE in slot 1
QPC43 Peripheral Signaling card	Core/Net: 10 Net: 4
QPC71 E&M/DX Trunk card	IPE: any slot but "Contr"
QPC414 Network card	Core/Net: 0-7 Net: 5-12
QPC441 3-Port Extender card	Core/Net: 11 Net: 1
QPC471 Clock Controller card	61C Core/Net: 9 Net: 5 -12 For 81C, use NT8D35 Net slot 13; in QSD39 shelf, use Net slot 2; in QSD40 shelf, use slot 13
QPC513 Enhanced Serial Data Interface card	Core/Net: 9, 13
QPC578 Integrated Services Digital Line card	IPE: any slot but "Contr"
QPC659 Dual Loop Peripheral Buffer card	IPE: "DLB"
QPC720 Primary Rate Interface card	Core/Net: 0-7 Net: 5-11, 13-14
QPC775 Clock Controller	61C Core/Net: slot 14. For 81C use NT8D35 Net slot 13; in QSD39 shelf, use Net slot 2; in QSD40 shelf, use slot 13.
QPC789 16-Port 500/2500 Message Waiting Line card	IPE: any slot but "Contr"
QPC841 4-Port Serial Data Interface card	Core/Net: 0-7

## Precautions

To avoid personal injury and equipment damage, review the following guidelines before handling system equipment.



### **WARNING**

Module covers are not hinged; do not let go of the covers. Lift covers away from the module and set them out of your work area.



### **WARNING**

Circuit cards may contain a lithium battery. There is a danger of explosion if the battery is incorrectly replaced. Do not replace components on any circuit card; you must replace the entire card.

Dispose of circuit cards according to the manufacturer's instructions.

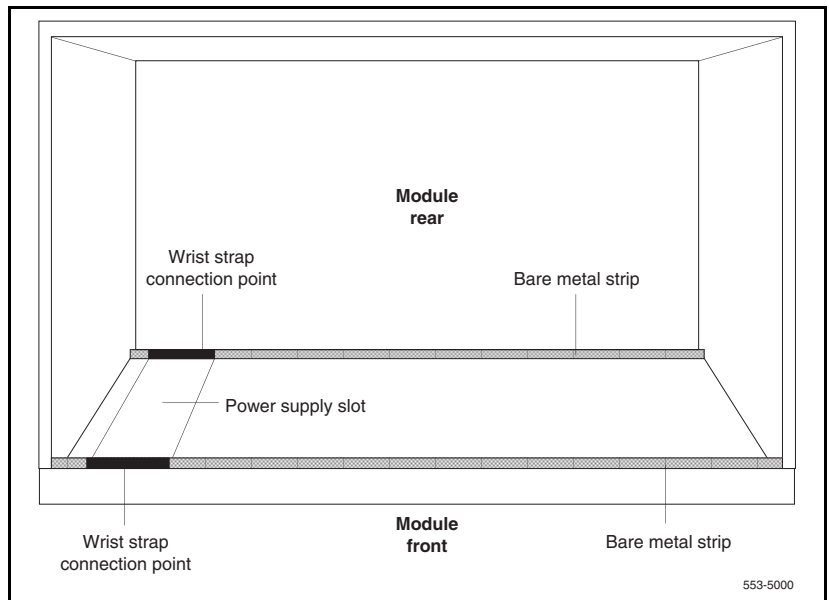
To avoid damage to circuit cards from static discharge, wear a properly connected antistatic wrist strap when you work on system equipment. If a wrist strap is not available, regularly touch one of the bare metal strips in a module to discharge static. Figure 15 on [page 85](#) shows the recommended connection points for the wrist strap and the bare metal strips you should touch.

Handle circuit cards as follows:

- Unpack or handle cards away from electric motors, transformers, or similar machinery.
- Handle cards by the edges only. Do not touch the contacts or components.
- Set cards on a protective antistatic bag. If an antistatic bag is not available, hand-hold the card, or set it in a card cage unseated from the connectors.
- Store cards in protective packing. Do not stack cards on top of each other unless they are packaged.

- Keep cards installed in the system as much as possible to avoid dirty contacts and unnecessary wear.
- Store cards in a cool, dry, dust-free area.

**Figure 15**  
**Static discharge points**



During repair and maintenance procedures do the following:

- Turn off the circuit breaker or switch for a module power supply before the power supply is removed or inserted.
- In AC-powered systems, capacitors in the power supply must discharge. Wait five full minutes between turning off the circuit breaker and removing the power supply from the module.
- Software disable cards, if applicable, before they are removed or inserted.

- Hardware disable cards, whenever there is an enable/disable switch, before they are removed or inserted.
- Return defective or heavily contaminated cards to a repair center. Do not try to repair or clean them.

## Installing a circuit card

This procedure provides detailed installation instructions for circuit cards.



### **DANGER**

To avoid personal injury and equipment damage, read all of the guidelines in “Circuit card installation” on [page 80](#) before you begin installation and follow all guidelines throughout the procedure.

### **Procedure 1 Installation**

- 1 Open the protective carton and remove the circuit card from the antistatic bag. Return the antistatic bag to the carton and store it for future use.
- 2 Inspect the card components, faceplate, locking devices, and connectors for damage. If damaged, tag the card with a description of the problem and package it for return to a repair center.
- 3 Refer to the work order to determine the module and slot location for the card.
- 4 If there is an enable/disable (Enb/Dis) switch on the faceplate, set it to Dis.
- 5 If there are option switches or jumpers on the card, set them according to the work order (see “Option settings” on [page 101](#)).



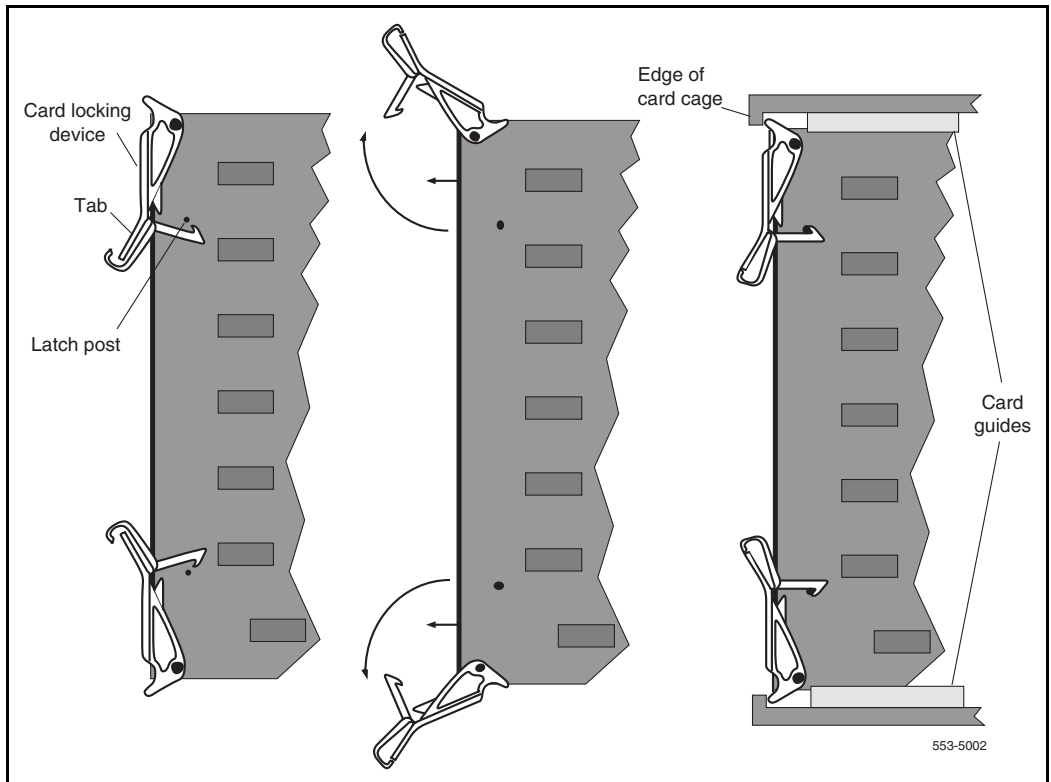
### **CAUTION**

#### **System Failure**

Incorrectly set switches on common equipment circuit cards may cause a system failure.

- 6 Squeeze the ends of the locking devices on the card and pull the tabs away from the latch posts and faceplate (see Figure 16).

**Figure 16**  
**Installing the circuit card in the card cage**



- 7 Insert the card into the card aligning guides in the card cage. Gently push the card into the slot until you feel resistance. The tip of the locking device must be behind the edge of the card cage (see Figure 16).
- 8 Lock the card into position by simultaneously pushing the ends of the locking devices against the faceplate.

**Note:** When IPE cards are installed, the red LED on the faceplate remains lit for two to five seconds as a self-test runs. If the self-test completes successfully, the LED flashes three times and remains lit until the card is configured and enabled in software, then the LED goes out. If the LED does not follow the pattern described or operates in any other manner (such as continually flashing or remaining weakly lit), replace the card.

- 9    If there is an enable/disable switch, set it to Enb.  
**Note:** Do not enable the switch on an NT8D04 Superloop Network card or QPC414 Network card until network loop cables are installed.
- 10   If you are adding a voice, conference, or tone and digit loop, press the manual initialize (Man Int) button on the NT5D03 or the NT5D10 Call Processor if the card is associated with the active Call Processor:  
**Note:** An initialization causes a momentary interruption in call processing.
- 11   If you are installing the card in a working system, refer to the work order and the *Software Input/Output: Administration* (553-3001-311) to add the required office data to the system memory.
- 12   Go to the appropriate test procedure in “Acceptance tests” on [page 89](#).



---

# Acceptance tests

---

## Contents

This section contains information on the following topics:

Introduction . . . . .	89
Conference cards . . . . .	90
Digitone receiver cards . . . . .	92
Line cards . . . . .	93
Multifrequency sender cards . . . . .	94
Multifrequency signaling cards . . . . .	95
Network cards . . . . .	95
Trunk cards . . . . .	96
Tone and digit switch cards . . . . .	97

## Introduction

Test procedures for most circuit cards require that internal and external cabling be installed. See the appropriate installation document for your system and *Telephones and Consoles: Description, Installation, and Operation* (553-3001-367) for cabling procedures.

## Conference cards

### Procedure 2 Testing conference cards

Use this procedure to test a conference card or to test the conference function of an NT8D17 Conference/TDS card.

- 1 Log into the system:

**LOGI** (password)

- 2 Request the status of a loop on the conference card:

**LD 38**  
**STAT loop**

Conference status is formatted as follows:

**CNFC n DSBL n BUSY**

“n” represents the number of conference groups disabled and busy

**CHAN n DSBL n BUSY**

“n” represents the number of channels disabled and busy

**UNEQ**

card is not equipped in the system

**DSBL**

card is disabled in software

- 3 If the conference card loop is disabled, enable it.

For an NT8D17 Conference/TDS card, enter:

**ENLX loop**

(the conference loop is the odd loop of the conference/TDS loop pair)

**Note:** The conference/TDS card is not enabled automatically when it is inserted. You must enable the card with the command ENLX. (This command is used in LD 34 and LD 46 to address even loops and in LD 38 to address odd loops.) Enabling the loops with the command ENLL does not enable the hardware for the card.

For other than an NT8D17 Conference/TDS card, enter:

**ENLL loop**

(the conference loop must be an even loop for cards other than the NT8D17)

If the system response is other than **OK**, see the *Software Input/Output: Administration* (553-3001-311) to analyze the messages.

- 4 Test the conference loop for channel, group, and switching faults:  
**CNFC loop**

If the conference loop passes the tests, the output is **OK**.

If the system response is other than **OK**, see the *Software Input/Output: Administration* (553-3001-311) to analyze the messages.

- 5 Prepare the system for a manual conference call on a specified loop:  
**CNFC MAN loop c**

Where “c” is the manual conference group (1-15)

A manual conference test is performed by stepping through conference channels and groups, listening for noise that indicates a faulty card.

The manual conference test can be performed through a system terminal or BCS maintenance telephone. If commands are entered from a maintenance telephone, this telephone automatically becomes part of the manual conference call.

Only one manual conference call is allowed at one time. A manual conference consists of only two telephones, where one telephone acts as a signal source while the other acts as a listening monitor.

After you enter the CNFC command, any two telephones (one may already be the maintenance telephone) dialing the special service prefix code (SPRE) and the digits 93 will enter the manual conference call. The prime directory number (PDN) indicator, if equipped, will light on each telephone.

Going on-hook takes the telephone out of the manual conference call, and the test must be restarted.

See LD 38 in the *Software Input/Output: Administration* (553-3001-311) for more detailed information on using this command.

- 6 Test various channels and conference groups audibly with the command  
**CNFC STEP**

When stepping through channels and groups, a clicking followed by silence is normal. Any distortion or other noises indicates a faulty card.

Once the CNFC STEP command has been entered, entering **C** on the system terminal or maintenance telephone steps through the conference channels. Entering **G** steps through the conference groups. There are 15 channels per group and 15 groups per conference card.

Entering an asterisk (\*) and END stops the test.

Again, see "LD 38" in the *Software Input/Output: Maintenance* (553-3001-511) for detailed information on using this command.

- 7 End the session in LD 38:  
\*\*\*\*

---

**End of Procedure**

---

## Digitone receiver cards

### Procedure 3

#### Testing digitone receiver cards

Use this procedure to test a Digitone receiver (DTR) card, a DTR daughterboard, or the DTR function on the NT8D18 Network/DTR card.

**Note:** The DTR daughterboard connected to a QPC659 Dual Loop Peripheral Buffer card cannot be assigned when the IPE shelf is used in single loop mode.

- 1 Log into the system:  
**LOGI** (password)
- 2 See if the Digitone receiver to be tested is disabled:  
**LD 34**  
**STAT**

The system responds with the terminal number (TN), or numbers, of any disabled Digitone receivers.

- 3 If the Digitone receiver is disabled, enable it:  
**ENLR I s c u**loop, shelf, card, and unit numbers
- 4 Test the Digitone receiver:  
**DTR I s c u**loop, shelf, card, and unit numbers

If the system response is other than **OK**, see the *Software Input/Output: Administration* (553-3001-311) to analyze the messages.

- 5 End the session in LD 34:  
\*\*\*\*

---

**End of Procedure**

---

---

## Line cards

### Procedure 4 Testing line cards

Use this procedure to test a line card.

- 1 Log into the system:  
**LOGI** (password)
- 2 Perform a network memory test, continuity test, and signaling test on a specific loop and shelf:  
**LD 30**  
**SHLF I** sloop and shelf numbers  
  
If the system response is other than **OK**, see the *Software Input/Output: Administration* (553-3001-311) to analyze the messages.
- 3 For a line card on a superloop, perform a signaling test on a specific card or unit:

**UNTT I s c** loop, shelf, and card numbers

For the NT8D02 Digital Line card, enter:

**UNTT I s c u** loop, shelf, card, and unit numbers

If the system response is other than **OK**, see the *Software Input/Output: Administration* (553-3001-311) to analyze the messages.

- 4 End the session in LD 30:  
\*\*\*\*

---

**End of Procedure**

---

## Multifrequency sender cards

### Procedure 5 Testing multifrequency sender cards

Use this procedure to test a multifrequency sender (MFS) card or the MFS function of an NT8D17 Conference/TDS card.

- 1 Log into the system:  
**LOGI** (password)
- 2 Test and enable an MFS loop:  
**LD 46**  
**MFS loop**  
(on the NT8D17 Conference/TDS card, the TDS/MFS loop is the even loop of the conference/TDS loop pair)

**Note:** The conference/TDS card is not enabled automatically when it is inserted. You must enable the card with the command ENLX. (This command is used in LD 34 and LD 46 to address even loops and in LD 38 to address odd loops.) Enabling the loops with the command ENLL does not enable the hardware for the card.

If the system response is other than **OK**, see the *Software Input/Output: Administration* (553-3001-311) to analyze the messages.

- 3 Access the system from a maintenance telephone; then enter:  
**LD 46**  
  
Give the system approximately 20 seconds to load the program.  
  
See "Communicating with the Meridian 1" in the *Software Input/Output: Administration* (553-3001-311) for details on accessing the system from a maintenance telephone.
- 4 Obtain 10-second bursts of digits 1 to 9, 0, and 11 to 15 (in that order) for all digits on the specified loop:  
**TONE loop ALL**  
  
Each burst should sound different. If the bursts do not sound different, replace the card.
- 5 End the session in LD 46:  
\*\*\*\*

---

End of Procedure

---

---

## Multifrequency signaling cards

### Procedure 6 Testing multifrequency signaling cards

Use this procedure to test a multifrequency signaling card.

- 1 Log into the system:  
**LOGI** (password)
- 2 Test and enable the specified unit:  
**LD 54**  
**ATST l s c u**      loop, shelf, card, and unit numbers  
  
If the system response is other than **OK**, see the *Software Input/Output: Administration* (553-3001-311) to analyze the messages.
- 3 End the session in LD 54:  
\*\*\*\*

---

**End of Procedure**

---

## Network cards

### Procedure 7 Testing network cards

Use this procedure to test a network card.

- 1 Log into the system:  
**LOGI** (password)
- 2 Perform a network memory test, continuity test, and signaling test:  
**LD 30**  
**LOOP loop**      can be a specific loop number or ALL  
  
If ALL is specified, all enabled loops (except attendant console loops) and all shelves on each loop are tested.  
  
If only one loop is being tested and it is disabled, enter **ENLL loop** to enable and test a network card associated with the specified loop. (This command cannot enable network cards disabled by LD 32.)  
  
If the system response is other than **OK**, see the *Software Input/Output: Administration* (553-3001-311) to analyze the messages.

- 3 End the session in LD 30:  
\*\*\*\*

---

**End of Procedure**

---

## Trunk cards

Use the following procedures to test a trunk card.

### Procedure 8

#### Testing a trunk card using a maintenance telephone

- 1 Access the system from a maintenance telephone.  
  
See "Communicating with the Meridian 1" in the *Software Input/Output: Administration* (553-3001-311) for details on accessing the system from a maintenance telephone.
- 2 Test the trunk unit:  
**LD 36**  
**TRK I s c u**                      loop, shelf, card, and unit numbers
- 3 If the maintenance telephone is hooked up to a monitor and the system response is other than **OK**, see the *Software Input/Output: Administration* (553-3001-311) to analyze the messages.

---

**End of Procedure**

---

### Procedure 9

#### Testing a trunk card using a system terminal

- 1 Log into the system:  
**LOGI** (password)
- 2 Enter:  
**LD 36**
- 3 To test a trunk from a remote test center, seize a central office (CO) monitor trunk:  
**CALL**  
or  
**CALL I s c u**  
  
Seize the automatic number identification (ANI) trunk:  
**TRK I s c u**                      loop, shelf, card, and unit numbers



When you see the **DN?** prompt, enter the directory number (DN) you want the system to dial.

If the system response is other than **OK**, see the *Software Input/Output: Administration* (553-3001-311) to analyze the messages.

- 4 End the session in LD 36:

\*\*\*\*

- 5 Test an automatically identified outward dialing (AIOD) trunk card:

**LD 41**

**AIOD I s c** loop, shelf, and card numbers

If the system response is other than **OK**, see the *Software Input/Output: Administration* (553-3001-311) to analyze the messages.

- 6 End the session in LD 41:

\*\*\*\*

---

**End of Procedure**

---

## Tone and digit switch cards

### Procedure 10

#### Testing tone and digit switch cards

Use this procedure to test a tone and digit switch (TDS) card or to test the TDS function of an NT8D17 Conference/TDS card.

- 1 Log into the system:  
**LOGI** (password)
- 2 Obtain a list of terminal numbers (TNs) for disabled TDS cards:  
**LD 34**  
**STAD**

- 3 If the TDS loop to be tested is disabled, enable it.

For an NT8D17 Conference/TDS card, enter:

**ENLX loop**

(the TDS/MFS loop is the even loop of the conference/TDS loop pair)

**Note:** The conference/TDS card is not enabled automatically when it is inserted. You must enable the card with the command ENLX. (This command is used in LD 34 and LD 46 to address even loops and in LD 38 to address odd loops.) Enabling the loops with the command ENLL does not enable the hardware for the card.

For other than an NT8D17 Conference/TDS card, enter:  
**ENLL loop**

- 4 Test the TDS loop:  
**TDS loop**

If the system response is other than **OK**, see the *Software Input/Output: Administration* (553-3001-311) to analyze the messages.

- 5 End the session in LD 34:  
 \*\*\*\*

- 6 Using a maintenance telephone, log into the system.

See “Communicating with the Meridian 1” in the *Software Input/Output: Administration* (553-3001-311) for details on accessing the system using a maintenance telephone.

- 7 From the maintenance telephone, enter:  
**LD#34##**

To test outpulsers and channels for the TDS loop, see Table 13 on [page 98](#) for a sample of the input commands used with the maintenance telephone. See the *Software Input/Output: Administration* (553-3001-311) for all tones that can be tested.

- 8 Exit LD 34 from the maintenance telephone:  
 \*\*\*\*

---

**End of Procedure**

---

**Table 13**  
**TDS tone tests**

<b>Input command</b>	<b>Dial pad equivalent</b>	<b>Description</b>
BSY#loop##	279#loop##	Provides busy tone from TDS loop specified.
C##	2##	Removes any active tone.
DIA#loop##	342#loop##	Provides dial tone from TDS loop specified.
OVF#loop##	683#loop##	Provides overflow tone from TDS loop specified.
RBK#loop##	725#loop##	Provides ringback tone from TDS loop specified.

**Table 13**  
**TDS tone tests**

RNG#loop##	764#loop##	Provides ring tone from TDS loop specified.
****		Exits TDS test program.



---

# Option settings

---

## Contents

This section contains information on the following topics:

Circuit card grid . . . . .	102
NT1R20 Off-Premise Station card . . . . .	104
General purpose switch settings . . . . .	107
NT6D42 Ringing Generator DC . . . . .	114
NT5D2101/NT9D1102 Core/Network module backplane . . . . .	117
NT6D68 Core module backplane . . . . .	117
NT6D80 Multi-purpose Serial Data Link card . . . . .	118
NT8D14 Universal Trunk card . . . . .	119
NT8D15 E&M Trunk card . . . . .	124
NT8D17 Conference/TDS card . . . . .	125
NT8D21 Ringing Generator AC . . . . .	126
NT8D22 System Monitor . . . . .	127
NT8D41BA Quad Serial Data Interface Paddle Board . . . . .	132
NT8D72 Primary Rate Interface card . . . . .	134
QPC43 Peripheral Signaling card . . . . .	136
QPC71 E&M/DX Signaling and Paging Trunk cards . . . . .	136
QPC414 Network card . . . . .	137
QPC441 3-Port Extender cards . . . . .	138
QPC559, QPC560 Loop Signaling Trunk cards . . . . .	141

QPC528 CO/FX/WATS Trunk cards . . . . .	143
QPC471 Clock Controller card . . . . .	144
QPC525, QPC526, QPC527, QPC777 CO Trunk card . . . . .	145
QPC550 Direct Inward Dial Trunk card . . . . .	146
QPC551 Radio Paging Trunk card . . . . .	149
QPC595 Digitone Receiver cards . . . . .	150
QPC577, QPC596 Digitone Receiver daughterboards . . . . .	150
QPC720 Primary Rate Interface card . . . . .	150
QPC775 Clock Controller card . . . . .	152
QPC841 4-Port Serial Data Interface card . . . . .	153

## Circuit card grid

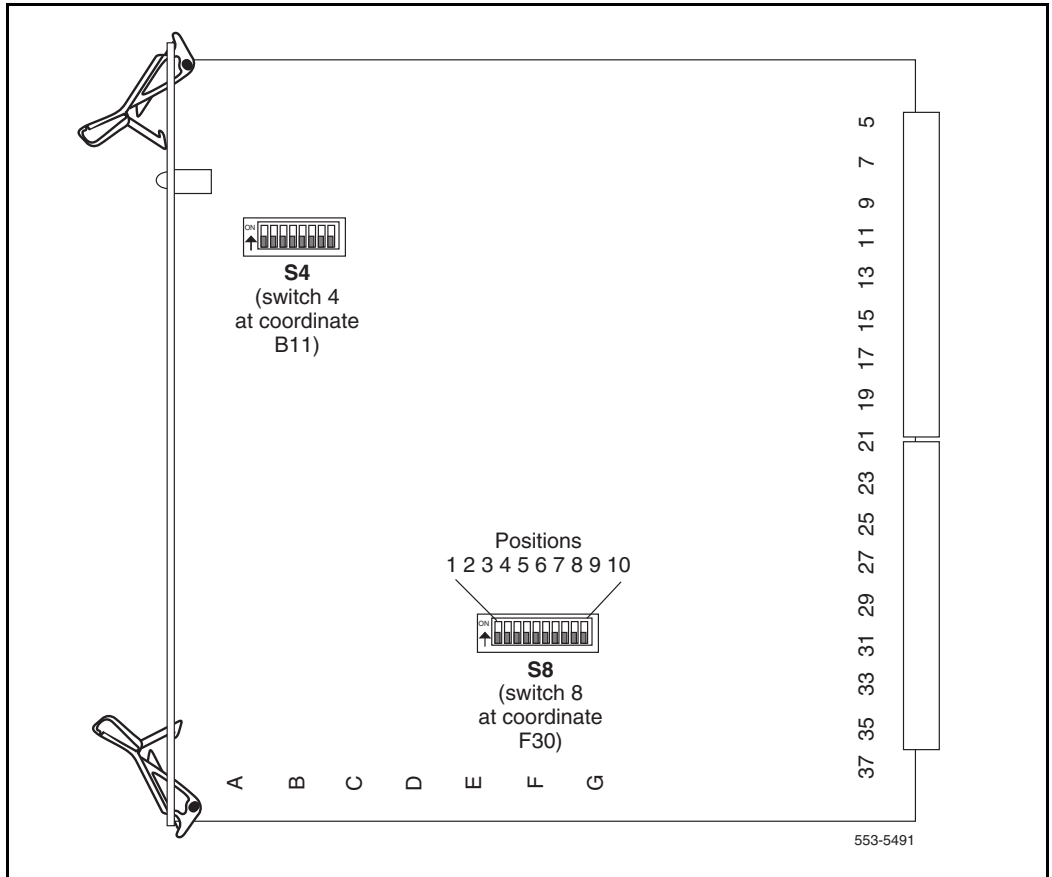
Some circuit cards contain option switches or jumpers, or both, that define specific functions. A switch or jumper can be identified by an alphanumeric coordinate (such as D29) that indicates a location on the card, or by a switch number (such as SW2) printed on the circuit board (see Figure 17). Positions on a switch (for example, positions 1, 2, 3, and 4 on SW2) are labeled on the switch block.

On a circuit card:

- ON may be indicated by the word “on,” the word “up,” the word “closed,” the number “1,” an arrow pointing up, or a solid dot (•).
- OFF may be indicated by the word “down,” the word “open,” the number “0,” or an arrow pointing down.

Throughout this document, if neither ON nor OFF is given (there is a blank space) for a position on a switch, that position may be set to either ON or OFF because it has no function for the option described.

**Figure 17**  
**Circuit card grid**



## NT1R20 Off-Premise Station card

Table 14 lists option settings for the NT1R20 Off-Premise Station analog card.

**Table 14**  
**OPS analog line card configuration (Part 1 of 3)**

Application	On-premise station (ONS)	Off-premise station (OPS)	
Class of Service (CLS) (Note 1)	ONP	OPX	
Loop resistance (ohms)	0–460	0–2300 (Note 2)	
Jumper strap setting (Note 6)	Both JX.0 and JX.1 off	Both JX.0 and JX.1 off	Both JX.0 and JX.1 on

**Note 1:** Configured in the Analog (500/2500-type) Telephone Administration program (LD 10).

**Note 2:** The maximum signaling range supported by the OPS analog line card is 2300 ohms.

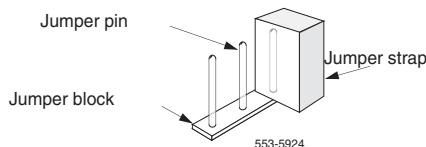
**Note 3:** Loss of untreated (no gain devices) metallic line facility. Upper loss limits correspond to loop resistance ranges for 26 AWG wire.

**Note 4:** Default software impedance settings are:

	<u>ONP CLS</u>	<u>OPX CLS</u>
<b>TIMP:</b>	600 ohms	600 ohms
<b>BIMP:</b>	600 ohms	3COM2

**Note:** Gain treatment, such as a voice frequency repeater (VFR) is required to limit the actual OPS loop loss to 4.5 dB, maximum. VFR treatment of metallic loops having untreated loss greater than 15 dB (equivalent to a maximum signaling range of 2300 ohms on 26 AWG wire) is not recommended.

**Note:** Jumper strap settings JX.0 and JX.1 apply to all eight units; “X” indicates the unit number, 0–7. “Off” indicates that a jumper strap is not installed across both pins on a jumper block. Store unused straps on the OPS analog line card by installing them on a single jumper pin as shown below:





**Table 14**  
**OPS analog line card configuration (Part 2 of 3)**

Application	On-premise station (ONS)			Off-premise station (OPS)			
Class of Service (CLS) (Note 1)	ONP			OPX			
Loop loss (dB) (Note 3)	0–1.5	>1.5–2.5	>2.5–3.0	0–1.5	>1.5–2.5	>2.5–4.5	>4.5–15
TIMP (Notes 1, 4)	600 ohms	600 ohms	600 ohms	600 ohms	600 ohms	600 ohms	600 ohms

**Note 1:** Configured in the Analog (500/2500-type) Telephone Administration program (LD 10).

**Note 2:** The maximum signaling range supported by the OPS analog line card is 2300 ohms.

**Note 3:** Loss of untreated (no gain devices) metallic line facility. Upper loss limits correspond to loop resistance ranges for 26 AWG wire.

**Note 4:** Default software impedance settings are:

	<u>ONP CLS</u>	<u>OPX CLS</u>
<b>TIMP:</b>	600 ohms	600 ohms
<b>BIMP:</b>	600 ohms	3COM2

**Note:** Gain treatment, such as a voice frequency repeater (VFR) is required to limit the actual OPS loop loss to 4.5 dB, maximum. VFR treatment of metallic loops having untreated loss greater than 15 dB (equivalent to a maximum signaling range of 2300 ohms on 26 AWG wire) is not recommended.

**Note:** Jumper strap settings JX.0 and JX.1 apply to all eight units; “X” indicates the unit number, 0–7. “Off” indicates that a jumper strap is not installed across both pins on a jumper block. Store unused straps on the OPS analog line card by installing them on a single jumper pin as shown below:

553-5924

**Table 14**  
**OPS analog line card configuration (Part 3 of 3)**

Application	On-premise station (ONS)			Off-premise station (OPS)			
Class of Service (CLS) (Note 1)	ONP			OPX			
BIMP (Notes 1, 4)	600 ohms	3COM1	3COM2	600 ohms	3COM1	3COM2	3COM2
Gain treatment (Note 5)	No						Yes

**Note 1:** Configured in the Analog (500/2500-type) Telephone Administration program (LD 10).

**Note 2:** The maximum signaling range supported by the OPS analog line card is 2300 ohms.

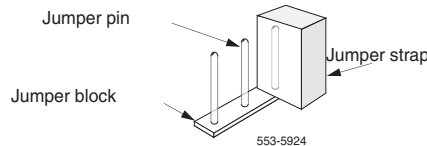
**Note 3:** Loss of untreated (no gain devices) metallic line facility. Upper loss limits correspond to loop resistance ranges for 26 AWG wire.

**Note 4:** Default software impedance settings are:

	<u>ONP CLS</u>	<u>OPX CLS</u>
<b>TIMP:</b>	600 ohms	600 ohms
<b>BIMP:</b>	600 ohms	3COM2

**Note:** Gain treatment, such as a voice frequency repeater (VFR) is required to limit the actual OPS loop loss to 4.5 dB, maximum. VFR treatment of metallic loops having untreated loss greater than 15 dB (equivalent to a maximum signaling range of 2300 ohms on 26 AWG wire) is not recommended.

**Note:** Jumper strap settings JX.0 and JX.1 apply to all eight units; “X” indicates the unit number, 0–7. “Off” indicates that a jumper strap is not installed across both pins on a jumper block. Store unused straps on the OPS analog line card by installing them on a single jumper pin as shown below:



## NT5D12AA Dual DTI/PRI (DDP) card

Switch setting tables for this card are listed in subsections according to their function. Bold font designates factory (default) settings.

### General purpose switches

Use switch set SW9 for Trunk 0; use switch set SW15 for Trunk 1 (see Table 15).

**Table 15**  
**General purpose switch settings**

Switch	Description	SW9/SW15 switch setting
1	Framing Mode	off - ESF on - SF
2	Yellow Alarm Method	off - FDL on - Digit2
3	Zero Code Suppression Mode	off - B8ZS on - AMI
4	Unused	off

### Trunk interface switches

A switch provides selection of T1 transmission. Use switch SW4 for Trunk 0; use switch SW10 for Trunk 1 (see Table 16).

**Table 16**  
**Trunk interface transmission mode switch settings**

Description	SW4/SW10 switch setting
For future use	off
T1	on

A set of three switches provides selection of dB values. Use SW5, SW6, and SW7 for Trunk 0; use SW11, SW12, and SW13 for Trunk 1 (see Table 17).

**Table 17**  
**Trunk interface line build out switch settings**

Description	Switch Setting		
	SW5/SW11	SW6/SW12	SW7/SW13
0 dB	off	off	off
7.5 dB	on	on	off
15 dB	on	off	on

A set of four DIP switches provides selection among three values for receiver impedance. Use SW8 for Trunk 0; use SW14 for Trunk 1 (see Table 18).

**Table 18**  
**Trunk interface impedance switch settings**

Description	SW8/SW14 Switch Settings			
75 Ω	off	off	on	off
100 Ω	on	off	off	on
120 Ω	off	off	off	on

---

## Ring ground switches

A set of four DIP switches selects which Ring lines are connected to ground (see Table 19).

**Table 19**  
**Ring ground switch settings**

<b>Switch</b>	<b>Description</b>	<b>S2 switch setting</b>
1	Trunk 0 Transmit	off - Ring line is not grounded on- Ring line is grounded
2	Trunk 0 Receive	off - Ring line is not grounded on - Ring line is grounded
3	Trunk 1 Transmit	off - Ring line is not grounded on - Ring line is grounded
4	Trunk 1 Receive	off - Ring line is not grounded on - Ring line is grounded

## DCH mode and address select switches

One switch selects an on-board NTBK51AA D-Channel daughterboard and an external MSDL/DCHI card. Four other switches provide the daughterboard address (see Table 20).

**Table 20**  
DCH mode and address select switch settings

Switch	Description	S3 Switch Setting
1-4	D-Channel daughterboard Address	See the next table.
5-7	For future use	off
8	External DCH or Onboard DDCH	off - MSDL or DCHI card on - Onboard DDCH daughterboard

**Table 21**  
NTBK51AA daughterboard address select switch settings (Part 1 of 2)

Device Address <sup>1</sup>	Switch Setting			
0 <sup>2</sup>	off	off	off	off
1	on	off	off	off
2	off	on	off	off
3	on	on	off	off
4	off	off	on	off
5	on	off	on	off
6	off	on	on	off
7	on	on	on	off
8	off	off	off	on

**Table 21**  
**NTBK51AA daughterboard address select switch settings (Part 2 of 2)**

Device Address <sup>1</sup>	Switch Setting			
9	on	off	off	on
10	off	on	off	on
11	on	on	off	on
12	off	off	on	on
13	on	off	on	on
14	off	on	on	on
15	on	on	on	on
<p><b>Note 1:</b> The maximum number of DCHI, MSDL, and DDCH devices in the system is 16.</p> <p>The Device Addresses are equivalent to the MSDL DNUM designations. For programming information on the MSDL, refer to <i>NTP Software Input/Output: Administration (553-3001-311) guide</i>.</p> <p><b>Note 2:</b> Device address 0 is commonly assigned to the System Monitor.</p>				

## Illustrations of switch locations and settings

Figure 18 on [page 112](#) displays functional areas for switches on the NT5D12AA DDP card.

**Figure 18**  
**Switch functions and areas**

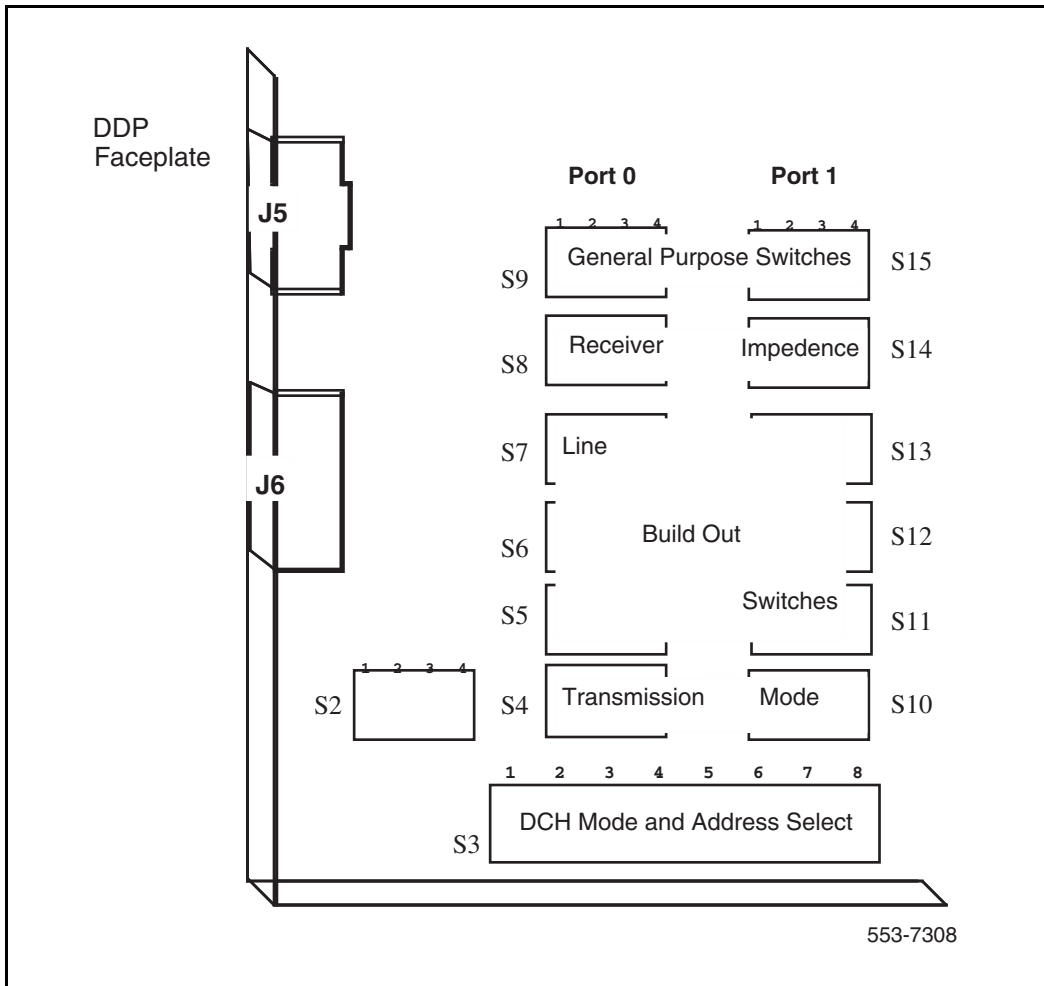
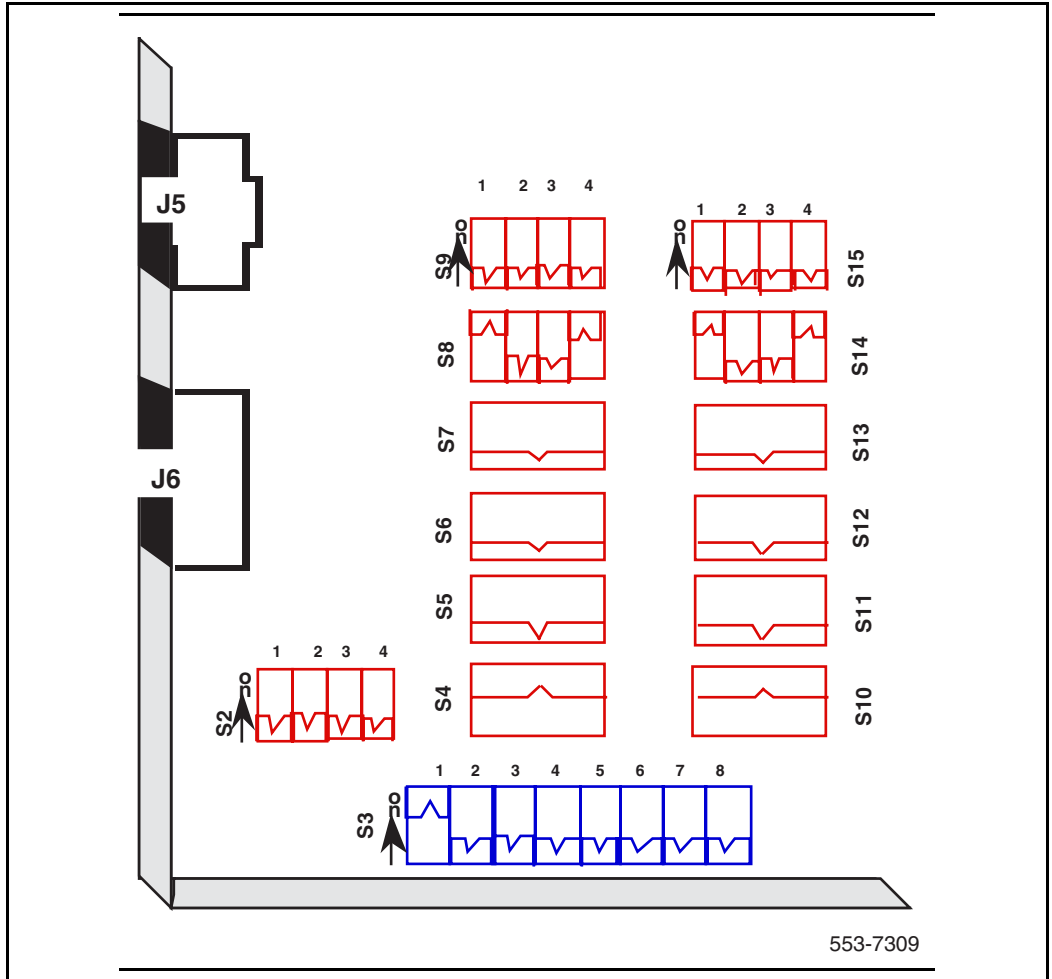




Figure 19 displays default settings for switches on the NT5D12AA DDP card.

**Figure 19**  
**Switch default settings**



## NT6D42 Ringing Generator DC

Tables 22 through 27 list option settings for the NT6D42 Ringing Generator.

**Table 22**  
**NT6D42 recommended options for North American and British Telecom**

Application	Ringling frequency	Ringling voltage	Jumper locations	Ringling output
North America	20 Hz	86 V ac	P5 High voltage message waiting	Low impedance
British Telecom	25 Hz	80 V ac	P4 No high voltage message waiting	Low impedance

**Table 23**  
**NT6D42 jumper locations P4 and P5**

High voltage message waiting	Pin location
Disable	Jumper in P4
Enable	Jumper in P5
<b>Note:</b> One jumper must be installed.	

**Table 24**  
**NT6D42 jumper location J7**

Ringling output	Jumper location J7
Low impedance (normal)	Connect pins 1 and 2
High impedance (Australia)	Connect pins 2 and 3

**Table 25**  
**NT6D42 SW1**

Ringling frequency (Hz)	Position SW1
20	1
25	2
50	3

**Table 26**  
**NT6D42CB SW2**

		SW2			
Ringling voltage	Message waiting voltage	1	2	3	4
86 V ac	-120 V dc	off	off	off	off
86 V ac	-150 V dc	off	off	off	on
80 V ac	-120 V dc	on	off	off	off
80 V ac	-150 V dc	on	off	off	on
75 V ac	-120 V dc	off	on	off	off
75 V ac	-150 V dc	off	on	off	on
70 V ac	-120 V dc	off	off	on	off
70 V ac	-150 V dc	off	off	on	on

**Table 27**  
**NT6D42CC SW2**

		<b>SW2</b>			
<b>Ringing voltage</b>	<b>Message waiting voltage</b>	<b>1</b>	<b>2</b>	<b>3</b>	<b>4</b>
86 V ac	-100 V dc	off	off	off	off
86 V ac	-150 V dc	off	off	off	on
80 V ac	-100 V dc	on	off	off	off
80 V ac	-150 V dc	on	off	off	on
75 V ac	-100 V dc	off	on	off	off
75 V ac	-150 V dc	off	on	off	on
70 V ac	-100 V dc	off	off	on	off
70 V ac	-150 V dc	off	off	on	on

## NT5D2101/NT9D1102 Core/Network module backplane

**Table 28**  
NT5D2101/NT9D1102 Core/Network module backplane

Jumper	Location (between slots)	Core/Network 1	Core/Network 0
JB1	14/15	Jumper plug not installed	Plug installed
<b>Note:</b> Berg jumper is located at the bottom of the primary side of the backplane. (This is inside the card cage assembly.)			

## NT6D68 Core module backplane

**Table 29**  
NT6D68 Core module backplane

Jumper	Location (between slots)	Core 1	Core 0
JB4	9 / 10	Jumper plug not installed	Plug installed
JB3	10 / 11	Plug installed	Plug installed
JB2	11 / 12	Plug installed	Plug installed
JB1	12 / 13	Plug installed	Plug installed
<b>Note:</b> Berg jumpers are located along the bottom of the primary side of the backplane. (This is inside the card cage assembly.)			

## NT6D80 Multi-purpose Serial Data Link card

**Table 30**  
**NT6D80 Multi-purpose Serial Data Link card**

	Port 0—SW4	Port 0—SW8
RS-232-D DTE or DCE*	all off	all off
RS-422-A DTE (terminal)	all off	all on
RS-422-A DCE (modem)	all on	all off
	Port 1—SW3	Port 1—SW7
RS-232-D DTE or DCE*	all off	all off
RS-422-A DTE	all off	all on
RS-422-A DCE	all on	all off
	Port 2—SW2	Port 2—SW6
RS-232-D DTE or DCE*	all off	all off
RS-422-A DTE	all off	all on
RS-422-A DCE	all on	all off
	Port 3—SW1	Port 3—SW5
RS-232-D DTE or DCE*	all off	all off
RS-422-A DTE	all off	all on
RS-422-A DCE	all on	all off
<p>* RS-232-D DTE and DCE modes are software configured. RS-422-A DTE and DEC modes are switch configured.</p> <p><b>Note:</b> The device number for the MSDL card is configured in LD17 at the prompt DNUM. You must also set the device number, using switches S9 and S10, on the MSDL card. S9 designates ones and S10 designates tens. To set the device number as 14, for example, set S10 to 1 and S9 to 4.</p>		

## NT8D14 Universal Trunk card

Tables 31 through 35 list option settings for the NT8D14 Universal Trunk card.

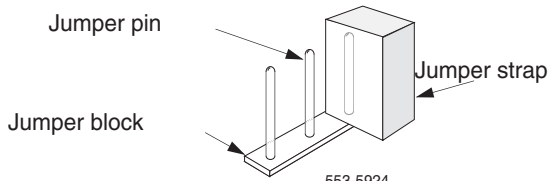
**Table 31**  
**NT8D14 vintage AA jumper strap settings**

Modes	Location	Jumper strap
Central Office (CO)	J1, J2	off
2-way tie trunk (loop dial repeat)	J1, J2	off
2-way tie trunk (outgoing/incoming dial)	J1, J2	off
Recorded announcement (RAN)	J1, J2	off
Paging trunk	J1, J2	off
Japan CO/DID operation	J1, J2	off
DID operation: loop length $\geq 2000 \frac{3}{4}$	J1, J2	on
DID operation: loop length $< 2000 \frac{3}{4}$	J1, J2	off
<b>Note 1:</b> off = no strap present.		
<b>Note 2:</b> Locations (J1, J2) apply to all eight units.		

**Table 32**  
**NT8D14 vintages BA/BB jumper strap settings—factory standard**

Trunk types	Loop length	Jumper strap settings			
		J1.X	J2.X	J3.X	J4.X
CO/FX/WATS	Zero–1524 m (5000 ft)	Off	Off	1–2	1–2
2-way tie (LDR)					
2-way tie (OAID)					
DID	Zero–600 ohms				
RAN: continuous operation mode	Not applicable: RAN and paging trunks should not leave the building.				
Paging					

**Note:** Jumper strap settings J1.X, J2.X, J3.X, and J4.X apply to all eight units; “X” indicates the unit number, 0–7. “Off” indicates that no jumper strap is installed on a jumper block. Store unused straps on the universal trunk card by installing them on a single jumper pin as shown below:



553-5924



**Table 33**  
**NT8D14 vintages BA/BB jumper strap settings—extended range**

Trunk types	Loop length	Jumper strap settings			
		J1.X	J2.X	J3.X	J4.X
CO/FX/WATS	> 1524 m (5000 ft)	Off	Off	1–2	2–3
2-way tie (LDR)					
2-way tie (OAID)					
DID	> 600 ohms	On	On	1–2	2–3
RAN: pulse start or level start modes	Not applicable: RAN trunks should not leave the building.	Off	Off	2–3	1–2

**Note:** Jumper strap settings J1.X, J2.X, J3.X, and J4.X apply to all eight units; “X” indicates the unit number, 0–7. “Off” indicates that no jumper strap is installed on a jumper block.

**Table 34**  
**NT8D14 vintages BA/BB trunk types—termination impedance and balance network**  
**(Part 1 of 2)**

Trunk types	Terminating impedance (Note 1)	Balance network for loop lengths (Note 2)		
		Zero–915 m (zero–3000 ft)	915–1524 m (3000–5000 ft)	> 1524 m (> 5000 ft)
CO/FX/WATS	600 or 900 ohms	600 ohms	3COM1	3COM2
2-way tie (LDR)	600 or 900 ohms	600 ohms	3COM1	3COM2

**Note 1:** The terminating impedance of each trunk unit is software selectable in LD 14 and should match the nominal impedance of the connecting equipment.

**Note 2:** The balance network of each trunk unit is software selectable between resistive 600 or 900 ohms or 3COM and is jumper selectable between 3COM1 and 3COM2.

**Table 34**  
**NT8D14 vintages BA/BB trunk types—termination impedance and balance network**  
**(Part 2 of 2)**

Trunk types	Terminating impedance (Note 1)	Balance network for loop lengths (Note 2)		
		Zero–915 m (zero–3000 ft)	915–1524 m (3000–5000 ft)	> 1524 m (> 5000 ft)
2-way tie (OAID)	600 or 900 ohms	600 ohms	3COM1	3COM2
DID (loop < 600 ohms)	600 or 900 ohms	600 ohms	3COM1	3COM2
DID (loop $\geq$ 600 ohms)	600 or 900 ohms	600 ohms	N/A	3COM2
RAN: continuous operation mode	600 or 900 ohms	600 or 900 ohms	N/A	N/A
Paging	600 ohms	600 ohms	N/A	N/A
<p><b>Note 1:</b> The terminating impedance of each trunk unit is software selectable in LD 14 and should match the nominal impedance of the connecting equipment.</p> <p><b>Note 2:</b> The balance network of each trunk unit is software selectable between resistive 600 or 900 ohms or 3COM and is jumper selectable between 3COM1 and 3COM2.</p>				

**Table 35**  
**NT8D14 vintages BA/BB cable loop resistance and loss**

Cable length	Cable loop resistance (ohms)			Cable loop loss (dB) (non-loaded at 1kHz)		
	22 AWG	24 AWG	26 AWG	22 AWG	24 AWG	26 AWG
915 m (3000 ft)	97	155	251	0.9	1.2	1.5
1524 m (5000 ft)	162	260	417	1.6	2.0	2.5
2225 m (7300 ft)	236	378	609	2.3	3.0	3.7
3566 m (11700 ft)	379	607	977	3.7	4.8	6.0
5639 m (18500 ft)	600	960	1544	5.9	7.6	9.4

## NT8D15 E&M Trunk card

Table 36  
NT8D15 E&M Trunk card

Jumper (Note 1)	Mode of operation (Note 2)					
	2-wire trunk		4-wire trunk			
	Type I	Paging	Type I	Type II	DX tip & ring pair	
					M—rcv M—xmt	E—rcv M—xmt
J1.X	off	off	off	off	Pins 1–2	Pins 2–3
J2.X	on	on (Note 3)	on	on	off	off
J3.X	off	off	off	off	(Note 4)	(Note 4)
J4.X	off	off	off	off	Pins 2–3	Pins 1–2
J5.X	off	off	off	off	(Note 4)	(Note 4)
J6.X	off	off	off	off	on	on
J7.X	off	off	off	off	on	on
J8.X	off	off	off	off	on	on
J9.X	Pins 2–3	Pins 2–3	Pins 2–3	Pins 2–3	Pins 1–2	Pins 1–2

**Note 1:** Jumper strap settings J1.X through J9.X apply to all 4 units; “X” indicates the unit number, 0–3.

**Note 2:** Off indicates that no jumper strap is installed on a jumper block.

**Note 3:** Paging trunk mode is not zone selectable.

**Note 4:** Jumper strap installed in this location only if external loop resistance exceeds 2500 ohms.

**Note 5:** Dot next to the jumper block indicates pin 1.

## NT8D17 Conference/TDS card

Switch and jumper settings are used to select the companding law and to change the conference attenuation PAD levels. These PAD levels are used if prompt CPAD = 1 in LD97. The J1 connector on the faceplate is reserved for future use.

You can enable or disable a warning tone for conference calls. When the option is enabled, the tone lets callers know they are entering a conference call. The switch for this option is preset to disable the warning tone.

Companding law	Jumper at J3		
$\mu$ -law (North America), A-law	connect pins 2 and 3		
Special cases	connect pins 1 and 2		
Attenuation levels	SW2 (see Note)		
	1	2	3
10.2 db	on	on	on
8.5 db	on	off	on
6 db	off	on	on
6 db	off	off	on
4.5 db	on	on	off
3 db	on	off	off
0 db	off	on	off
0 db	off	off	off
<b>Note:</b> Set position 4 to ON to disable the warning tone option. When the warning tone is enabled, select the warning tone level as shown below.			
Level	Jumper at J2		
24 db	connect pins 1 and 2		
30 db	connect pins 2 and 3		

## NT8D21 Ringing Generator AC

Frequency	Amplitude	Settings		
		P1	P2	P3
20 Hz	86 V ac	open	open	2-5 8-11
25 Hz	70 V ac	open	1-4 7-10	open
25 Hz	80 V ac	open	3-6 9-12	open
25 Hz	86 V ac	open	2-5 8-11	open
50 Hz	70 V ac	1-4 7-10	open	open
50 Hz	80 V ac	3-6 9-12	open	open

## NT8D22 System Monitor

The master system monitor, located in the column with CP 0, must be numbered 0. Slave system monitors are numbered from 1 to 63.

For examples of system monitor option settings in basic configurations, see “Sample settings for NT8D22 System Monitors.”

Configure the system monitor in Remote Peripheral Equipment (RPE) columns as slaves. There is no serial connection between RPE columns.

**Table 37**  
**NT8D22 SW1**

SW1 function	Position							
	1	2	3	4	5	6	7	8
Not used Meridian 1 columns only	on off							
Position 1 is OFF (Meridian 1 columns only) Not used Position 1 is ON, master column contains CP:master slaves		off off on off						
DC-powered system AC-powered system			on off					
PFTU is activated by this column due to over-temperature PFTU is not activated by this column				on off				
Position 1 is OFF (Meridian 1 columns only) Not used Not used					off on off			
Position 1 is OFF (Meridian 1 columns only) Not used Not used						off on off		
Not used Not used Not used Meridian 1 columns only							on on off off	on off on off



**Table 38**  
**NT8D22 SW2**

SW2 indication	Position							
	1	2	3	4	5	6	7	8
Master system monitor Slave system monitor	on off							
Not used All other operation		on off						
For master, indicates total number of slaves			Configure 3–8 according to the Table 40 on <a href="#">page 130</a> .					
For each slave, indicates the slave address			Configure 3–8 according to the Table 41 on <a href="#">page 131</a> .					

**Table 39**  
**NT8D22 SW3**

SW3 indication		Position			
		1	2	3	4
CTA	master slave	on off			
CTR	master slave		on off		
FAIL	master slave			on off	
MAJOR	master slave				on off

**Table 40**  
**NT8D22 settings for total number of slaves—SW2 on master**

How many slave units	Switch position						How many slave units	Switch position					
	3	4	5	6	7	8		3	4	5	6	7	8
0	on	on	on	on	on	on	32	off	on	on	on	on	on
1	on	on	on	on	on	off	33	off	on	on	on	on	off
2	on	on	on	on	off	on	34	off	on	on	on	off	on
3	on	on	on	on	off	off	35	off	on	on	on	off	off
4	on	on	on	off	on	on	36	off	on	on	off	on	on
5	on	on	on	off	on	off	37	off	on	on	off	on	off
6	on	on	on	off	off	on	38	off	on	on	off	off	on
7	on	on	on	off	off	off	39	off	on	on	off	off	off
8	on	on	off	on	on	on	40	off	on	off	on	on	on
9	on	on	off	on	on	off	41	off	on	off	on	on	off
10	on	on	off	on	off	on	42	off	on	off	on	off	on
11	on	on	off	on	off	off	43	off	on	off	on	off	off
12	on	on	off	off	on	on	44	off	on	off	off	on	on
13	on	on	off	off	on	off	45	off	on	off	off	on	off
14	on	on	off	off	off	on	46	off	on	off	off	off	on
15	on	on	off	off	off	off	47	off	on	off	off	off	off
16	on	off	on	on	on	on	48	off	off	on	on	on	on
17	on	off	on	on	on	off	49	off	off	on	on	on	off
18	on	off	on	on	off	on	50	off	off	on	on	off	on
19	on	off	on	on	off	off	51	off	off	on	on	off	off
20	on	off	on	off	on	on	52	off	off	on	off	on	on
21	on	off	on	off	on	off	53	off	off	on	off	on	off
22	on	off	on	off	off	on	54	off	off	on	off	off	on
23	on	off	on	off	off	off	55	off	off	on	off	off	off
24	on	off	off	on	on	on	56	off	off	off	on	on	on
25	on	off	off	on	on	off	57	off	off	off	on	on	off
26	on	off	off	on	off	on	58	off	off	off	on	off	on
27	on	off	off	on	off	off	59	off	off	off	on	off	off
28	on	off	off	off	on	on	60	off	off	off	off	on	on
29	on	off	off	off	on	off	61	off	off	off	off	on	off
30	on	off	off	off	off	on	62	off	off	off	off	off	on
31	on	off	off	off	off	off	63	off	off	off	off	off	off

**Table 41**  
**NT8D22 slave address—SW2 on slave**

Slave unit address	Position						Slave unit address	Position					
	3	4	5	6	7	8		3	4	5	6	7	8
1	on	on	on	on	on	off	33	off	on	on	on	on	off
2	on	on	on	on	off	on	34	off	on	on	on	off	on
3	on	on	on	on	off	off	35	off	on	on	on	off	off
4	on	on	on	off	on	on	36	off	on	on	off	on	on
5	on	on	on	off	on	off	37	off	on	on	off	on	off
6	on	on	on	off	off	on	38	off	on	on	off	off	on
7	on	on	on	off	off	off	39	off	on	on	off	off	off
8	on	on	off	on	on	on	40	off	on	off	on	on	on
9	on	on	off	on	on	off	41	off	on	off	on	on	off
10	on	on	off	on	off	on	42	off	on	off	on	off	on
11	on	on	off	on	off	off	43	off	on	off	on	off	off
12	on	on	off	off	on	on	44	off	on	off	off	on	on
13	on	on	off	off	on	off	45	off	on	off	off	on	off
14	on	on	off	off	off	on	46	off	on	off	off	off	on
15	on	on	off	off	off	off	47	off	on	off	off	off	off
16	on	off	on	on	on	on	48	off	off	on	on	on	on
17	on	off	on	on	on	off	49	off	off	on	on	on	off
18	on	off	on	on	off	on	50	off	off	on	on	off	on
19	on	off	on	on	off	off	51	off	off	on	on	off	off
20	on	off	on	off	on	on	52	off	off	on	off	on	on
21	on	off	on	off	on	off	53	off	off	on	off	on	off
22	on	off	on	off	off	on	54	off	off	on	off	off	on
23	on	off	on	off	off	off	55	off	off	on	off	off	off
24	on	off	off	on	on	on	56	off	off	off	on	on	on
25	on	off	off	on	on	off	57	off	off	off	on	on	off
26	on	off	off	on	off	on	58	off	off	off	on	off	on
27	on	off	off	on	off	off	59	off	off	off	on	off	off
28	on	off	off	off	on	on	60	off	off	off	off	on	on
29	on	off	off	off	on	off	61	off	off	off	off	on	off
30	on	off	off	off	off	on	62	off	off	off	off	off	on
31	on	off	off	off	off	off	63	off	off	off	off	off	off
32	off	on	on	on	on	on							

## NT8D41BA Quad Serial Data Interface Paddle Board

### Baud rate

Switches SW13, SW10, SW11, and SW12 determine the baud rate for ports 1, 2, 3, and 4, respectively. See the configuration for these switches in Table 42.

**Table 42**  
**QSDI paddle board baud rate switch settings**

Baud rate	Baud Clock (kHz)	SW13 (port 1), SW10 (port 2), SW11 (port 3), SW12 (port 4)			
		1	2	3	4
150	2.40	on	off	on	on
300	4.80	on	on	off	on
600	9.60	on	off	off	on
1,200	19.20	on	on	on	off
2,400	38.40	on	off	on	off
4,800	76.80	on	on	off	off
9,600	153.60	on	off	off	off
19,200*	307.20	on	on	on	on

\* For future use.

### Address

Switch SW15 or SW16 and logic on the card always address the four UARTs using a pair of addresses: 0 and 1, 2 and 3 through 14 and 15. The

configurations for both switches are shown in Table 43. To avoid system problems, switches SW15 and SW16 must not be configured identically.

**Table 43**  
**QSDI paddle board address switch settings**

SW15	Port 1	Port 2	Switch settings							
SW16	Port 3	Port 4	1*	2*	3	4	5	6	7	8
Device pair addresses	0	1	E	X	off	off	off	off	off	off
	2	3	E	X	off	off	off	off	off	on
	4	5	E	X	off	off	off	off	on	off
	6	7	E	X	off	off	off	off	on	on
	8	9	E	X	off	off	off	on	off	off
	10	11	E	X	off	off	off	on	off	on
	12	13	E	X	off	off	off	on	on	off
	14	15	E	X	off	off	off	on	on	on

\* To enable ports 1 and 2, set SW15 position 1 to ON. To enable ports 3 and 4, set SW16 position 1 to ON.

+ For each X, the setting for this switch makes no difference, because it is not used.

### DTE/DCE mode

Each serial port can be configured to connect to a terminal (DTE equipment) or a modem (DCE equipment). Instructions for configuring the DTE/DCE switches SW2, SW3, SW4, SW5, SW6, SW7, SW8, and SW9 are shown in Table 44.

Example: Port 1 is changed from DTE to DCE by reversing every switch position on SW3 and SW2; i.e., switches that were off for DTE are turned on for DCE, and switches that were on for DTE are turned off for DCE.

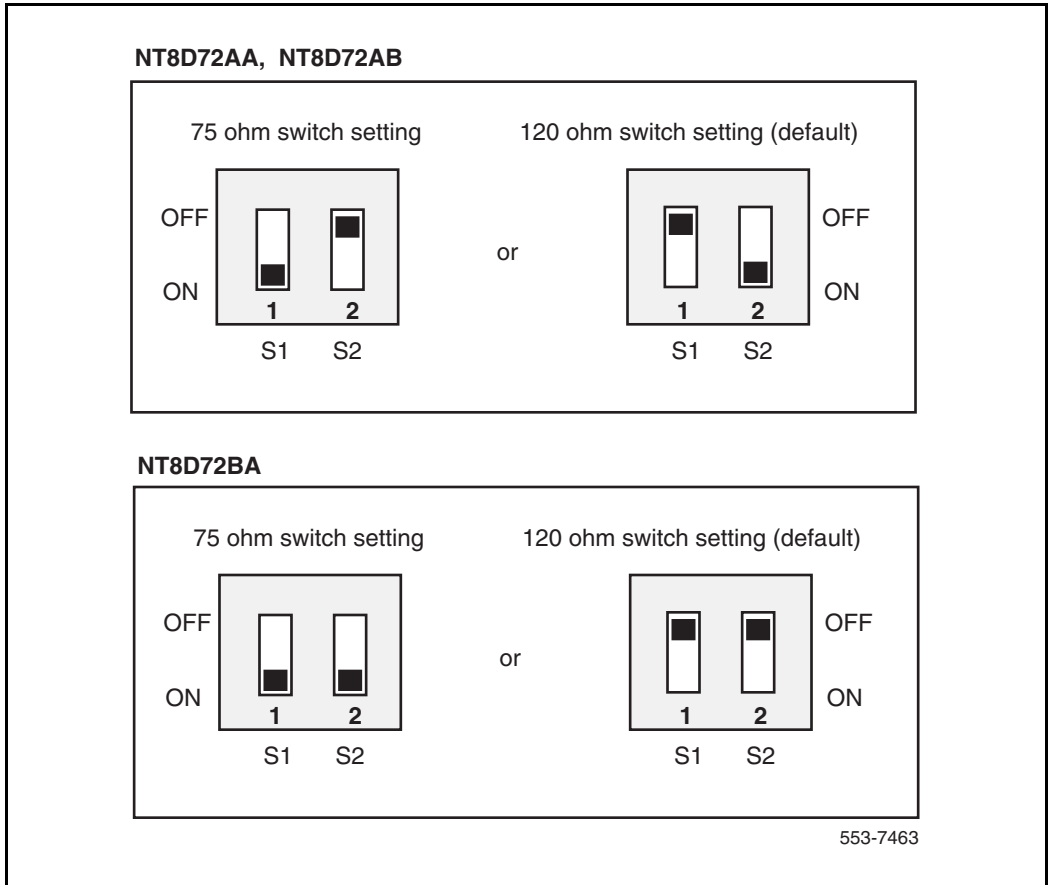
**Table 44**  
**QSDI paddle board DTE/DCE mode switch settings**

Mode	Port 1 — SW 3						Port 1 —SW 2					
	1	2	3	4	5	6	1	2	3	4	5	6
DTE (terminal)	on	on	on	off	on	off	off	on	off	on	off	on
DCE (modem)	off	off	off	on	off	on	on	off	on	off	on	off
	Port 2 — SW 5						Port 2 — SW4					
DTE (terminal)	on	on	on	off	on	off	off	on	off	on	off	on
DCE (modem)	off	off	off	on	off	on	on	off	on	off	on	off
	Port 3 — SW 7						Port 3— SW 6					
DTE (terminal)	on	on	on	off	on	off	off	on	off	on	off	on
DCE (modem)	off	off	off	on	off	on	on	off	on	off	on	off
	Port 4 — SW 9						Port 4 — SW 8					
DTE (terminal)	on	on	on	off	on	off	off	on	off	on	off	on
DCE (modem)	off	off	off	on	off	on	on	off	on	off	on	off

## NT8D72 Primary Rate Interface card

The NT8D72 Primary Rate Interface card allows the configuration of interface impedance by way of DIP switches.

**Figure 20**  
**NT8D72 DIP switch settings**



## QPC43 Peripheral Signaling card

Options (minimum vintage N)	Plug location
NT5D21 Core/Network module	F13
NT8D35 Network module	

## QPC71 E&M/DX Signaling and Paging Trunk cards

Application	Unit 0 E35 switch								Unit 1 E5 switch							
	1	2	3	4	5	6	7	8	1	2	3	4	5	6	7	8
E&M	off	off	off	on	off	off	on	off	off	off	off	on	off	off	on	off
Paging	off	off	off	off	off	off	off	off	off	off	off	off	off	off	off	off
DX 2-wire (conductor loop < 2.5 K <sup>3</sup> / <sub>4</sub> )	on	on	off	off	off	on	off	on	on	on	off	off	off	on	off	on
DX 2-wire (conductor loop > 2.5 K <sup>3</sup> / <sub>4</sub> )	on	on	on	on	off	on	off	on	on	on	on	on	off	on	off	on
DX 4-wire (conductor loop < 2.5 K <sup>3</sup> / <sub>4</sub> )	off	off	off	off	on	on	off	on	off	off	off	off	on	on	off	on
DX 4-wire (conductor loop > 2.5 K <sup>3</sup> / <sub>4</sub> )	off	off	on	on	on	on	off	on	off	off	on	on	on	on	off	on

**Note:** DX trunks must be balanced correctly. If the loop is <2.5 K <sup>3</sup>/<sub>4</sub>, far-end balancing is standard. If the loop is >2.5 K <sup>3</sup>/<sub>4</sub>, far end balancing requires standard plus 2.5 K <sup>3</sup>/<sub>4</sub>. To connect PBX to PBX, switches should be arranged for loops to be >2.5 K <sup>3</sup>/<sub>4</sub> at one end and <2.5 K <sup>3</sup>/<sub>4</sub> at the other. Apply similar treatment when connecting to Pulse QPJ69 trunks.



## QPC414 Network card

<b>Application</b>	<b>Pin connection J3/S2 and J4/S1</b>
T-1 facilities (including PRI/DTI),* channel service unit	connect pins 1 and 2 (pin 1 is next to the white dot)
<p><b>Note 1:</b> Possible jumper locations for vintage B (for different styles/series):            J3—E11 or H11            J4—H17 or E7            S1 and S2—E33</p> <p><b>Note 2:</b> Possible jumper locations for vintage A (for different styles/series). These cards do not have the option selection and can only be used in the option A setting:            J3—H5 or E11            J4—H17 or E7            S1 and S2—E33</p> <p><b>Note 3:</b> Connectors and loop relations:            Even loop: J1 faceplate connector, jumper at J4 or S1            Odd loop: J2 faceplate connector, jumper at J3 or S2</p>	

## QPC441 3-Port Extender cards

For CS 1000M SG and Multi Group systems, QPC441 vintage F or later must be used in all modules.

**Table 45**  
**QPC441 3PE card installed in the NT4N41CP PII Core/Net modules**

<b>Jumper Settings:</b> Set Jumper RN27 at E35 to "A".									
Switch Settings									
Module		D20 switch position							
NT4N41 CP Core/Net modules only		1	2	3	4	5	6	7	8
Core/Net 0 (Shelf 0)	Group 0	off	on	on	off	on	on	on	on
	Group 1	off	on	on	off	on	on	off	on
	Group 2	off	on	on	off	on	off	on	on
	Group 3	off	on	on	off	on	off	off	on
	Group 4	off	on	on	off	off	on	on	on
	Group 5	off	on	on	off	off	on	off	on
	Group 6	off	on	on	off	off	off	on	on
	Group 7	off	on	on	off	off	off	off	on
Core/Net 1 (Shelf 1)	Group 0	off	on	on	off	on	on	on	off
	Group 1	off	on	on	off	on	on	off	off
	Group 2	off	on	on	off	on	off	on	off
	Group 3	off	on	on	off	on	off	off	off
	Group 4	off	on	on	off	off	on	on	off
	Group 5	off	on	on	off	off	on	off	off
	Group 6	off	on	on	off	off	off	on	off
	Group 7	off	on	on	off	off	off	off	off

**Table 46**  
**QPC441 3PE card installed in the NT5D21 modules**

<b>Jumper Settings: Set Jumper RN27 at E35 to "A".</b>									
<b>Switch Settings</b>									
<b>Module</b>	<b>D20 switch position</b>								
	<b>1</b>	<b>2</b>	<b>3</b>	<b>4</b>	<b>5</b>	<b>6</b>	<b>7</b>	<b>8</b>	
NT5D21 (Option 61C)									
Core/Network 0	off	on	on	off	on	on	on	on	on
Core/Network 1	off	on	on	off	on	on	on	on	off
NT5D21 (Option 81C)									
Core/Net 0 (Shelf 0)	Group 0	off	on	on	off	on	on	on	on
	Group 1	off	on	on	off	on	on	off	on
	Group 2	off	on	on	off	on	off	on	on
	Group 3	off	on	on	off	on	off	off	on
	Group 4	off	on	on	off	off	on	on	on
	Group 5	off	on	on	off	off	on	off	on
	Group 6	off	on	on	off	off	off	on	on
	Group 7	off	on	on	off	off	off	off	on
Core/Net 1 (Shelf 1)	Group 0	off	on	on	off	on	on	on	off
	Group 1	off	on	on	off	on	on	off	off
	Group 2	off	on	on	off	on	off	on	off
	Group 3	off	on	on	off	on	off	off	off
	Group 4	off	on	on	off	off	on	on	off
	Group 5	off	on	on	off	off	on	off	off
	Group 6	off	on	on	off	off	off	on	off
	Group 7	off	on	on	off	off	off	off	off

**Table 47**  
**QPC441 3PE card installed in the NT8D35 module**

<b>Jumper Settings:</b> Set Jumper RN27 at E35 to "A".									
<b>Switch Settings</b>									
<b>Modules</b>		<b>D20 switch position</b>							
		<b>1</b>	<b>2</b>	<b>3</b>	<b>4</b>				
<b>Option 81, 81C (Note 1)</b>		off	on	on	on				
<b>Shelf</b>	<b>Group</b>					<b>5</b>	<b>6</b>	<b>7</b>	<b>8</b>
0	0					on	on	on	on
	1					on	on	off	on
	2					on	off	on	on
	3					on	off	off	on
	4					off	on	on	on
	5					off	on	off	on
	6					off	off	on	on
	7					off	off	off	on
1	0					on	on	on	off
	1					on	on	off	off
	2					on	off	on	off
	3					on	off	off	off
	4					off	on	on	off
	5					off	on	off	off
	6					off	off	on	off
	7					off	off	off	off

## QPC559, QPC560 Loop Signaling Trunk cards

Table 48 and Table 49 on [page 142](#) list option settings for loop signaling trunk cards.

**Table 48**  
**QPC559, QPC560 single density**

Application	Single density—Unit 0/1 F30/F8 switch					
	1	2	3	4	5	6
Outgoing ANI only:						
loop pulsing	off	off	off	off	off	off
battery and ground pulsing	off	off	off	off	on	off
Other than outgoing ANI	on	off	on	off	on	off
	Jumpers (QPC560) Units 0/1/2/3					
600 $\frac{3}{4}$ resistive impedance	connect pins 1 and 2					
3-component complex impedance	connect pins 2 and 3					

**Table 49**  
**QPC559, QPC560 double density**

<b>Application</b>	<b>Double density—Unit 0/1/2/3 H17/H3/A17/A3 switch</b>					
	<b>1</b>	<b>2</b>	<b>3</b>	<b>4</b>	<b>5</b>	<b>6</b>
Outgoing ANI only:						
loop pulsing	off	off	off	off	off	off
battery and ground pulsing	off	off	off	off	on	off
Other than outgoing ANI	on	off	on	off	on	off
	<b>Jumpers (QPC560) Units 0/1/2/3</b>					
600 $\frac{3}{4}$ resistive impedance	connect pins 1 and 2					
3-component complex impedance	connect pins 2 and 3					

## QPC528 CO/FX/WATS Trunk cards

Table 50 lists switch and jumper settings for options available.

**Table 50**  
**QPC528 Trunk cards switch and jumper settings**

Switch Settings										
Switch position:	Switch S1 (location A23)									
	1	2	3	4	5	6	7	8		
	on	off	on	off	on	off	on	off		
Switch position:	Unit 0, Switch S2 (Location E29) Unit 1, Switch S3 (Location E9) Unit 2, Switch S4 (Location A28) Unit 3, Switch S5 (Location A10)									
	1	2	3	4	5	6	7	8	9	10
Trunk type:										
Loop start	off	on	off	off	on	off			off	off
Ground start	off	on	on	on	on	off			off	off
Metering:										
Second pair (M, MM) or							off	off		
Third wire, battery on M or							off	on		
Third wire, ground on M							on	off		
Jumper Settings										
Jumper:	Unit 0 jumper (Location E27) Unit 1 jumper (Location E11) Unit 2 jumper (Location D29) Unit 3 jumper (Location D9)									
	<b>Unit 0 Jumper</b>	<b>Unit 1 Jumper</b>		<b>Unit 2 Jumper</b>		<b>Unit 3 Jumper</b>				
600 $\frac{3}{4}$ resistive impedance	Pin 1 to 2	Pin 1 to 2		Pin 1 to 2		Pin 1 to 2				
3-component complex impedance	Pin 2 to 3	Pin 2 to 3		Pin 2 to 3		Pin 2 to 3				

## QPC471 Clock Controller card

Table 51 lists option settings for the QPC471 Clock Controller card.

**Table 51**  
**QPC471 vintage H**

System	SW1				SW2				SW4				
	1	2	3	4	1	2	3	4	1	2	3	4	
61C	on	on	on	on	off	off	off	off	off	on	*	*	
81	off	off	off	off	off	off	off	off	off	on	*	*	
81C	on	off	off	off	off	off	off	off	**	on	*	*	
81C with Fiber Network	on	off	off	off	off	off	off	off	**	on	*	*	
					*Cable length between the J3 faceplate connectors:								
					0–4.3 m (0–14 ft)					off		off	
					4.6–6.1 m (15–20 ft)					off		on	
					6.4–10.1 m (21–33 ft)					on		off	
					10.4–15.2 m (34–50 ft)					on		on	
<p>* If there is only one Clock Controller card in the system, set to OFF. If there are two Clock Controller cards, determine the total cable length between the J3 connectors (no single cable can exceed 25 ft.) and set these two switch positions for this cable length, as shown above. The maximum total (combined) length is 50 ft. Set the switches on both cards to the same settings.</p> <p>** Set to ON for clock controller 0. Set to OFF for clock controller 1.</p> <p><b>Note:</b> FNF based-systems the total clock path length is equal to the length of the NTRC49 cable used to connect between the two clock controller cards.</p>													



## QPC525, QPC526, QPC527, QPC777 CO Trunk card

Application	Switches at E29/E9/A29/A11 Units 0/1/2/3							
	1	2	3	4	5	6	7	8
Zero ohm outpulsing	on	off						off
Standard outpulsing	off	on						off
Ground start			on	on				off
Loop start			off	off				off
Loop start, automatic guard detection			off	on				off
PPM daughterboard not installed					on			off
PPM daughterboard installed					off			off
Battery on M operation						off	on	off
Ground on M operation						on	off	off
Second pair M&MM						off	off	off

**Note 1:** There is no ground start signalling for QPC777 CO trunk cards. Always select loop start signalling for QPC777 CO trunk cards.

**Note 2:** On QPC777 CO trunk cards, the pads are in for short line lengths and the pads are out for long line lengths.

## QPC550 Direct Inward Dial Trunk card

Tables 52 through 56 give the option settings for the QPC550 DID Trunk card.

**Table 52**  
**QPC550 vintages A and B—real/complex balance impedance selection**

Device location	Device designation	Switch number	Unit number	Impedance type	
				Real	Complex
F31	S4.0	1	0	on	off
F24	S4.1	1	1	on	off
F16	S4.2	1	2	on	off
F11	S4.3	1	3	on	off

**Table 53**  
**QPC550 vintage A—600/900 Ohm impedance selection**

Device location	Device designation	Unit number	Impedance (ohms)	Switch number							
				1	2	3	4	5	6	7	8
G29(a)	S3.0	0	600	off	on	on	off	off	on	on	off
			900	on	off	off	on	on	off	off	on
G29(b)	S3.1	1	600	off	on	on	off	off	on	on	off
			900	on	off	off	on	on	off	off	on
G8(a)	S3.2	2	600	off	on	on	off	off	on	on	off
			900	on	off	off	on	on	off	off	on
G8(b)	S3.3	3	600	off	on	on	off	off	on	on	off
			900	on	off	off	on	on	off	off	on

**Table 54**  
**QPC550 vintage A—software/hardware control for 2dB pad**

Device location	Device designation	Unit number	Switch number	S/W	2 dB pad control H/W	
					(pad in)	(pad out)
F38	S1	0	1	off	off	on
			2	on	off	off
		1	3	on	off	off
			4	off	off	on
F1	S2	0	1	off	off	on
			2	on	off	off
		1	3	on	off	off
			4	off	off	on

**Table 55**  
**QPC550 vintage B—attenuation level control**

Device location	Device designation	Unit number	Switch number								2 dB option
			1	2	3	4	5	6	7	8	
D39	S2.0/1	0	on		on		on		on		on
		1		off		off		off		off	off
D1	S2.2/3	2	on		on		on		on		on
		3		off		off		off		off	off

**Table 56**  
**QPC550 vintage B—software control for 2dB pad**

Device location	Device designation	Unit number	Switch number	2 dB pad control H/W	
				(pad in)	(pad out)
F38	S1.0/1	1	1	on	off
			2	off	off
		0	3	off	off
			4	on	off
F1	S1.2/3	3	1	on	off
			2	off	off
		2	3	off	off
			4	on	off

## QPC551 Radio Paging Trunk card

Signal duration on the 18-pair faceplate							S1 (F33)					
	1	2	3	4	5	6						
Binary value (.1 second)	1	2	4	8	16	32						
<p><b>Note:</b> This switch determines the length of time a signal stays on the 18-pair data bus. The time is set in binary to the nearest tenth second. For example, to keep data on the bus for 5 seconds, the switch settings total 50 by closing S1.2, S1.5, and S1.6.</p>												
Signal duration and pause time							S2 (G33)					
	1	2	3	4	5	6	7					
Binary value (.1 second)	1	2	4	8	16	32	64					
<p><b>Note:</b> This switch determines the time data must stay on the 18-pair data bus plus the pause time between the removal of data and the reappearance of subsequent data. The time is set in binary to the nearest tenth second. For example, to keep data on the bus for 5 seconds and have a pause time of 3.2 seconds, the switch settings should total 82 by closing S2.2, S2.5, and S2.7.</p>												
Application			S3 (E2) S4 (F2) Unit 0, Unit 1									
	1	2	Address	3	4	5	6	Address	3	4	5	6
Paging			0	off	off	off	off	8	off	off	off	on
single	on		1	on	off	off	off	9	on	off	off	on
multiple	off		2	off	on	off	off	10	off	on	off	on
			3	on	on	off	off	11	on	on	off	on
Timer*			4	on	off	on	off	12	on	off	on	on
enabled		on	5	on	on	on	off	13	on	off	on	on
disabled		off	6	off	on	on	off	14	off	on	on	on
			7	on	on	on	off	15	on	on	on	on
<p>* When enabled, this switch prevents a signal from being sent from a paging unit until 5 seconds have elapsed since the beginning of the previous signal on that same unit.</p>												
			S5 (E38) Unit 0				S6 (D1) Unit 1					
Impedance termination			1									
Real			on									
Complex			off									

## QPC595 Digitone Receiver cards

	Location	Connection
12 DTMF tones	E9	Center to E3
16 DTMF tones	E9	Center to E2

## QPC577, QPC596 Digitone Receiver daughterboards

16/12 tone options jumper	Jumper at P1
16 tone (4 x 4)	connect pins 1 and 2
12 tone (3 x 4)	connect pins 2 and 3

**Note:** When a DTR daughterboard is installed, check YES on the faceplate of the QPC659 Dual Loop Peripheral Buffer.

## QPC720 Primary Rate Interface card

Table 57

QPC720 Primary Rate Interface card (Part 1 of 2)

Switch S2 settings	To repeater facility	To cross-connect point
5 on	0–45 m (0–150 ft)	0–30 m (0–100 ft)
2, 4, 6 on	46–135 m (151–450 ft)	31–100 m (101–355 ft)

**Note 1:** All positions on S2 (location B22) are OFF except as shown under the column labeled “Switch S2 settings.”

**Note 2:** Framing format, line encoding, and method of yellow alarm are selectable for both DTI and PRI in LD17 with the DLOP, LCMT, and YALM prompts. All SW3 switch positions should be OFF.

**Table 57**  
**QPC720 Primary Rate Interface card (Part 2 of 2)**

Switch S2 settings		To repeater facility	To cross-connect point
1, 3, 7 on		136–225 m (451–750 ft)	101–200 m (356–655 ft)
<b>Switch 3 option for DTI with ESF</b>			
SW3-1	on = extended superframe format (ESF) off = superframe format (SF)		
<p><b>Note 1:</b> All positions on S2 (location B22) are OFF except as shown under the column labeled “Switch S2 settings.”</p> <p><b>Note 2:</b> Framing format, line encoding, and method of yellow alarm are selectable for both DTI and PRI in LD17 with the DLOP, LCMT, and YALM prompts. All SW3 switch positions should be OFF.</p>			

## QPC775 Clock Controller card

Tables 58 and 59 give option settings for the QPC775 Clock Controller card.

**Table 58**  
**QPC775 (before vintage E) switch settings**

System	SW2				SW3				SW4			
	1	2	3	4	1	2	3	4	1	2	3	4
CS 1000M MG	off	off	off	off	off	off	off	off	on	on	on	on
CS 1000M SG	on	on	on	on	off	off	off	off	on	on	on	on

**Table 59**  
**QPC775 vintage E switch settings**

System	SW1				SW2				SW4			
	1	2	3	4	1	2	3	4	1	2	3	4
CS 1000M SG	on	on	on	on	off	off	off	off	off	on	*	*
CS 1000M MG	on	off	off	off	off	off	off	off	**	on	*	*
					*Cable length between the J3 faceplate connectors:							
					0–4.3 m (0–14 ft)				off		off	
					4.6–6.1 m (15–20 ft)				off		on	
					6.4–10.1 m (21–33 ft)				on		off	
					10.4–15.2 m (34–50 ft)				on		on	
<p>* If there is only one Clock Controller card in the system, set to OFF. If there are two Clock Controller cards, determine the total cable length between the J3 connectors (no single cable can exceed 25 ft.) and set these two switch positions for this cable length, as shown above. The maximum total (combined) length is 50 ft. Set the switches on both cards to the same settings.</p> <p>** Set to ON for clock controller 0. Set to OFF for clock controller 1.</p>												



## QPC841 4-Port Serial Data Interface card

Tables 60 through 62 list option settings for the QPC841 4-Port SDI card.

**Table 60**  
**QPC841 port 1 and 2 address selection**

Device number		SW14							
Port 1	Port 2	1	2	3	4	5	6	7	8
0	1	off	off	off	off	off	on	on	on
2	3	off	off	off	off	off	on	on	off
4	5	off	off	off	off	off	on	off	on
6	7	off	off	off	off	off	on	off	off
8	9	off	off	off	off	off	off	on	on
10	11	off	off	off	off	off	off	on	off
12	13	off	off	off	off	off	off	off	on
14	15	off	off	off	off	off	off	off	off

**Note 1:** On SW16, positions 1, 2, 3, and 4 must be OFF.

**Note 2:** To avoid address conflicts, SW14 and SW15 can never have identical setting.

**Note 3:** To disable ports 1 and 2, set SW14 position 1 to ON.

Device number		SW15							
Port 3	Port 4	1	2	3	4	5	6	7	8
0	1	off	off	off	off	off	on	on	on
2	3	off	off	off	off	off	on	on	off
4	5	off	off	off	off	off	on	off	on
6	7	off	off	off	off	off	on	off	off
8	9	off	off	off	off	off	off	on	on
10	11	off	off	off	off	off	off	on	off
12	13	off	off	off	off	off	off	off	on
14	15	off	off	off	off	off	off	off	off

**Note 1:** On SW16, positions 1, 2, 3, and 4 must be OFF.

**Note 2:** To avoid address conflicts, SW14 and SW15 can never have identical setting.

**Note 3:** To disable ports 3 and 4, set SW15 position 1 to ON.

**Table 61**  
**QPC841 baud rate**

Baud rate	Port 1 SW10				Port 2 SW11				Port 3 SW12				Port 4 SW13			
	1	2	3	4	1	2	3	4	1	2	3	4	1	2	3	4
150	off	off	on	on	off	off	on	on	off	off	on	on	off	off	on	on
300	off	on	off	on	off	on	off	on	off	on	off	on	off	on	off	on
600	off	off	off	on	off	off	off	on	off	off	off	on	off	off	off	on
1200	off	on	on	off	off	on	on	off	off	on	on	off	off	on	on	off
2400	off	off	on	off	off	off	on	off	off	off	on	off	off	off	on	off
4800	off	on	off	off	off	on	off	off	off	on	off	off	off	on	off	off
9600	off	off	off	off	off	off	off	off	off	off	off	off	off	off	off	off

**Table 62**  
**QPC841 DTE or DCE selection**

Mode	Port 1—SW8						Port 1—SW9					
	1	2	3	4	5	6	1	2	3	4	5	6
DTE (terminal)	on	on	on	on	on	on	off	off	off	off	off	off
DCE (modem)	off	off	off	off	off	off	on	on	on	on	on	on
NT1P61 (Fiber)	on	off	off	on	off	off	on	off	off	off	on	on
	Port 2—SW6						Port 2—SW7					
DTE	on	on	on	on	on	on	off	off	off	off	off	off
DCE	off	off	off	off	off	off	on	on	on	on	on	on
NT1P61 (Fiber)	on	off	off	on	off	off	on	off	off	off	on	on
	Port 3—SW4						Port 3—SW5					
DTE	on	on	on	on	on	on	off	off	off	off	off	off
DCE	off	off	off	off	off	off	on	on	on	on	on	on
	Port 4—SW2						Port 4—SW3					
DTE	on	on	on	on	on	on	off	off	off	off	off	off
DCE	off	off	off	off	off	off	on	on	on	on	on	on



---

# NT1R20 Off-Premise Station Analog Line card

---

## Contents

This section contains information on the following topics:

Introduction . . . . .	157
Physical description . . . . .	158
Functional description . . . . .	160
Electrical specifications . . . . .	165
Operation . . . . .	168
Connector pin assignments . . . . .	172
Configuring the OPS analog line card . . . . .	174
Application . . . . .	175

## Introduction

The NT1R20 Off-Premise Station (OPS) analog line card is an intelligent eight-channel analog line card designed to be used with 2-wire analog terminal equipment such as analog (500/2500-type) telephones and analog modems.

The NT1R20 Off-Premise Station (OPS) analog line card provides eight full-duplex analog telephone line interfaces. Each line has integral hazardous and surge voltage protection to protect the system from damage due to lightning strikes and accidental power line connections. This card is normally

used whenever the phone lines have to leave the building in which the switch is installed.

The NT1R20 OPS analog line card provides:

- line supervision
- hookflash
- battery reversal

Each unit is independently configured by software control in the Analog (500/2500 type) Telephone Administration program LD 10.

You can install this card in any IPE slot.

## Physical description

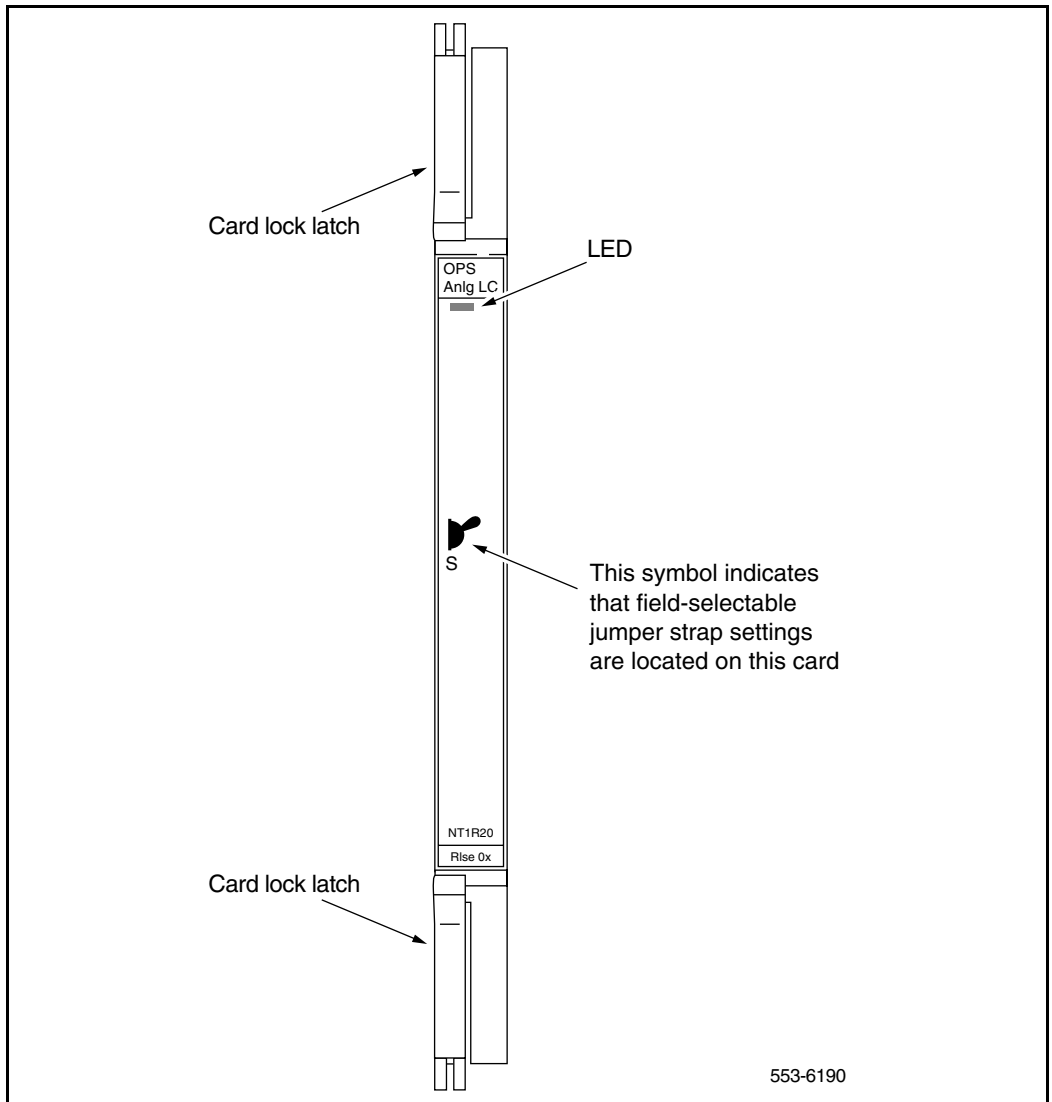
The line interface and common multiplexing circuitry is mounted on a 31.75 cm by 25.40 cm (12.5 in. by 10 in.) printed circuit board.

The OPS analog line card connects to the IPE backplane through a 160-pin connector shroud. A 25-pair amphenol connector below the card is cabled to the cross connect terminal (also called the Main Distribution Frame (MDF)). Telephone lines from station equipment cross connect to the OPS analog line card at the cross connect using a wiring plan similar to trunk cards.

## Self Test

The faceplate of the NT1R20 OPS analog line card is equipped with a red LED. When an OPS analog line card is installed, the LED remains lit for two to five seconds while the self-test runs. If the self-test completes successfully, the LED flashes three times and remains lit. When the card is configured and enabled in software; then the LED goes out. If the LED continues to flash or remains weakly lit, replace the card. See Figure 21 on [page 159](#).

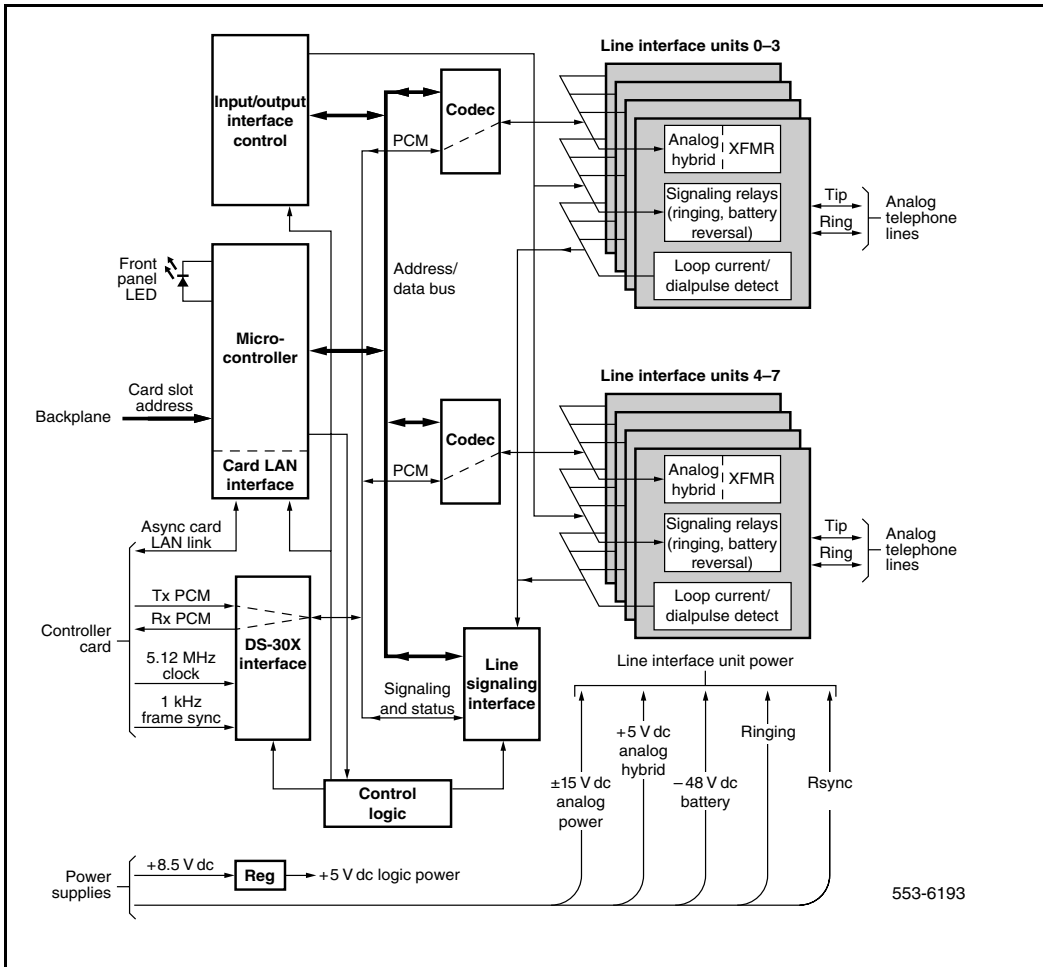
**Figure 21**  
**OPS analog line card – faceplate**



## Functional description

This functional description of the NT1R20 Off-Premise Station (OPS) analog line card is divided into two parts. First, a description of the card's control, signaling, and power interfaces is given, followed by a description of how the card itself functions. See Figure 22.

**Figure 22**  
OPS analog line card – block diagram





## Card interfaces

### Voice and signaling interfaces

The eight line interfaces provided by the NT1R20 OPS analog line card connect to conventional, 2-wire (tip and ring), analog line facilities. Incoming analog voice and signaling information from a line facility is converted by the OPS analog line card to digital form and routed to the CPU over DS-30 network loops. Conversely, digital voice and signaling information from the CPU is sent over DS-30 network loops to the OPS analog line card where it is converted to analog form and applied to the line facility.

The OPS analog line card uses only eight of the 30 available timeslots for its eight line interfaces. The OPS analog line card can be configured in software to format PCM data in the  $\mu$ -law or A-law conventions.

### Maintenance communication

Maintenance communication is the exchange of control and status data between line or trunk cards and the CPU. Maintenance data is transported through the card LAN link.

The card LAN link supports the following functions on the NT1R20 OPS analog line card:

- polling
- reporting of self-test status
- CPU initiated card reset
- reporting of card ID (card type and hardware vintage)
- reporting of firmware version
- reporting of line interface unit configuration
- enabling/disabling of the DS-30X network loop busy
- reporting of card status

### Power interface

Power is provided to the NT1R20 OPS analog line card by the NTAK78 ac/dc or NTAK72 DC power supply.

### **Line interface units**

The NT1R20 OPS analog line card contains eight independently configurable interface units. Relays are provided in each unit to apply ringing onto the line. Signal detection circuits monitor on-hook/off-hook signaling. Two codecs are provided for performing Analog/Digital (A/D) and Digital/Analog (D/A) conversion of analog voiceband signals to digital PCM signals.

Each codec supports four interface units and contains switchable pads for control of transmission loss on a per unit basis. The following features are common to all units on the card:

- OPS or ONS service configurable on a per unit basis
- terminating impedance (600 or 900 ohms) selectable on a per unit basis
- standard or complex balance impedance (600 or 900 ohms, 3COM1 or 3COM2) selectable on a per unit basis
- loopback of PCM signals over DS-30X network loop for diagnostic purposes

### **Signaling and control**

This portion of the card provides circuits that establish, supervise, and take down call connections. These circuits work with the CPU to operate line interface circuits during calls. The circuits receive outgoing call signaling messages from the CPU and return incoming call status information over the DS-30X network loop.

## **Card control functions**

Control functions are provided by a microcontroller, a card LAN interface, and signaling and control circuits on the NT1R20 OPS analog line card.

### **Microcontroller**

The NT1R20 OPS analog line card contains a microcontroller that controls the internal operation of the card and the serial card LAN link to the controller card. The microcontroller controls the following:

- reporting to the CPU through the card LAN link:
  - card identification (card type, vintage, and serial number)

- firmware version
- self-test status
- programmed configuration status
- receipt and implementation of card configuration:
  - programming of the codecs
  - enabling/disabling of individual units or entire card
  - programming of input/output interface control circuits for administration of line interface unit operation
  - maintenance diagnostics
  - transmission loss levels

### **Card LAN interface**

Maintenance data is exchanged with the CPU over a dedicated asynchronous serial network called the Card LAN link. The Card LAN link is described in the section “Intelligent Peripheral Equipment” on [page 32](#).

The NT1R20 OPS analog line card has the capability of providing an interrupted dial tone to indicate that a message is waiting or that call forwarding is enabled. The line card (optionally) receives messages stating that these conditions exist over the Card LAN Interface and interrupts the dial tone when either of these conditions are detected.

### **Software service changes**

Individual line interface units on the NT1R20 OPS analog line card are configured to either OPS (for OPS application) or On-premises Station (ONS) (for ONS application) Class of Service (CLS) in the Analog (500/2500-type) Telephone Administration program LD 10. See Table 63.

LD 10 is also used to select unit terminating impedance and balance network impedance at the TIMP and BIMP prompts, respectively.

The message waiting interrupted dial tone and call forward reminder tone features are enabled by entering data into the customer data block using LD 15.

See *Software Input/Output: Administration* (553-3001-311) for LD 10 service change instructions.

**Table 63**  
**OPS analog line card configuration**

Application	On-premise station (ONS)			Off-premise station (OPS)			
Class of service	ONS			OPS			
Loop resistance	0 - 460 ohm			0 - 2300 ohm			
Jumper strap setting <sup>b</sup>	Both JX. 0 and JX 1 off			Both JX. 0 and JX. 1 off		Both JX. 0 and JX. 1 on	
Loop loss dB <sup>c</sup>	0-1.5	>1.5-2.5	>2.5-3.0	0-1.5	>1.5-2.5	>2.5-4.5	>4.5-15
TIMP	600 ohm	600 ohm	600 ohm	600 ohm	600 ohm	600 ohm	600 ohm
BIMP	600 ohm	3COM	3CM2	600 ohm	3COM	3CM2	3CM2
Gain treatment <sup>e</sup>	No						Yes
<p><b>a.</b> Configured in the Analog (500/2500-type) Telephone Administration program (LD 10).</p> <p><b>b.</b> Jumper strap settings JX 0 and JX. 1 apply to all eight units; "X" indicates the unit number, 0-7. "OFF" indicates that a jumper strap is not installed across both pins on a jumper block. Store unused straps on the OPS analog line card by installing them on a single jumper pin.</p> <p><b>c.</b> Loss of untreated (no gain devices) metallic line facility. Upper loss limits correspond to loop resistance ranges for 26 AWG wire.</p> <p><b>d.</b> Default software impedance settings are:  <u>ONS CLSOPS CLS</u>                      TIMP:600 ohm600 ohm                      BIMP:600 ohm3COM2</p> <p><b>e.</b> Gain treatment, such as a voice frequency repeater (VFR) is required to limit the actual OPS loop loss to 4.5 dB, maximum. VFR treatment of metallic loops having untreated loss greater than 15dB (equivalent to a maximum signaling range of 2300 ohm on 26 AWG wire) is not recommended.</p>							

### **Port-to-port loss configuration**

The loss plan for the NT1R20 OPS analog line card determines port-to-port loss for connections between an OPS analog line card unit (port) and other ports.

The transmission properties of each line unit are characterized by the OPS or ONS class of service assigned in the Analog (500/2500-type) Telephone Administration program LD 10.

The OPS analog line card provides transmission loss switching for control of end-to-end connection loss. Control of loss is a major element in controlling transmission performance parameters such as received volume, echo, noise, and crosstalk. The loss plan for the OPS analog line card determines port-to-port loss for connections between an OPS analog line card unit (port) and other IPE ports. LD 97 is used to configure systems for port-to-port loss.

See *Software Input/Output: Administration* (553-3001-311) for LD 97 service change instructions.

## **Electrical specifications**

This section lists the electrical characteristics of the NT1R20 OPS analog line card.

### **Circuit power**

The +8.5 V dc input is regulated down to +5 V dc for use by the digital logic circuits. All other power to the card is used by the line interface circuits.

The  $\pm 15.0$  V dc inputs to the card are used to power the analog circuits. The +5 V dc from the module power supply is used for the analog hybrid. The  $-48.0$  V dc input is for the telephone battery. Ringing power for telephones is 86 Vrms ac at 20 Hz on  $-48$  V dc. The Rsync signal is used to switch the 20 Hz ringing on and off at the zero cross-over point to lengthen the life of the switching circuits.

## Analog line interface

Table 64 lists the electrical characteristics of NT1R20 OPS analog line card line interface units.

**Table 64**  
**OPS analog line card – electrical characteristics**

Characteristic	Specification
Terminal impedance (TIMP)	600 or 900 ohms
Balance impedance (BIMP)	600 or 900 ohms, 3COM, or 3CM2
DC signaling loop length (max)	2300 ohm loop (including resistance of telephone) with nominal battery of -48 V dc
Battery supply voltage	-42 to -52.5 V dc
Minimum detected loop current	16 mA
Ground potential difference	± 3 V
Line leakage	≥ 30k ohms, tip-to-ring, tip-to-ground, ring-to-ground
AC induction rejection	10 V rms, tip-to-ring, tip-to-ground, ring-to-ground

## Power requirements

Table 65 shows the maximum power consumed by the card from each system power supply.

**Table 65**  
**OPS analog line card – power requirements**

Voltage	Tolerance	Current (max.)
±15.0 V dc	± 5%	150 mA
+8.5 V dc	± 2%	200 mA
+5.0 V dc	± 5%	100 mA
–48.0 V dc	± 5%	350 mA

## Foreign and surge voltage protection

The NT1R20 OPS analog line card meets UL-1489 and CS03 over-voltage (power cross) specifications and FCC Part 68 requirements for hazardous and surge voltage limits.

## Ringer limitations

The OPS line card supports up to three NE-C4A (3 REN) ringers on each line for either ONS or OPS applications. See Table 66.

**Table 66**  
**OPS analog line card – ringer limitations (Part 1 of 2)**

ONS Loop Range	Maximum Number of Ringers (REN)
0–10 ohms	3
> 10–460 ohms	2

**Table 66**  
**OPS analog line card – ringer limitations (Part 2 of 2)**

<b>OPS Loop Range</b>	<b>Maximum Number of Ringers (REN)</b>
0 – 10 ohms	3
> 10 – 900 ohms	2
> 900 – 2300 ohms	1

## Environmental specifications

Table 67 shows the environmental specifications of the OPS analog line card.

**Table 67**  
**OPS analog line card – environmental specifications**

<b>Parameter</b>	<b>Specifications</b>
Operating temperature	0° to +60° C (+32 to +140° F), ambient
Operating humidity	5 to 95% RH (non-condensing)
Storage temperature	-40° to +70° C (-40° to +158° F)

## Operation

The applications, features, and signaling arrangements for each unit on the NT1R20 OPS analog line card are assigned through LD 10 and/or jumper strap settings on the card.





The operation of each unit is configured in software and implemented in the card through software download messages. When the NT1R20 OPS analog line card unit is idle, it provides a ground on the tip lead and -48 V dc on the ring lead. The on-hook telephone presents a high impedance toward the line interface unit on the card.




## Incoming calls

Incoming calls to a telephone connected to the NT1R20 OPS analog line card originate from stations that can be local (served by the PBX) or remote (served through the public switched telephone network). The alerting signal to telephones is 20 Hz (nominal) ringing. When an incoming call is answered, ringing is tripped as the telephone goes off-hook, placing a low-resistance dc loop across the tip and ring leads toward the OPS analog line card. (see Table 68).

**Table 68**  
**Call connection sequence—near-end station receiving call (Part 1 of 2)**

State	Signal / Direction Far-end / Near-end	Remarks
Line card unit idle	Group on tip, battery on ring High resistance loop	No battery current drawn.  Far-end station goes off-hook and addresses (dials-up) the near-end station. The system receives the incoming call on a trunk and determine the TN.
Incoming call	Ringing 	The system applies 20 Hz ringing to ring lead.
Near-end station off-hook	Low resistance loop 	
Two-way voice connection		The system detects increase in loop current, tips ringing, and put call through to near-end station.
Near end station hangs up first	High-resistance loop 	If near end station hangs-up first, the line card detects the drop in loop current.
Line card unit idle	Group on tip, battery on ring High resistance loop	Line card unit is ready for the next call.



**Table 68**  
**Call connection sequence—near-end station receiving call (Part 2 of 2)**

State	Signal / Direction Far-end / Near-end	Remarks
Far end station hangs up first	High resistance loop  	If the far-end hangs-up first, the system detects disconnect signalling from the trunk. The person at the near-end recognizes the end of the call and hangs-up.
Line card unit idle	Ground on tip/battery on ring High resistance loop	Line card unit is ready for the next call.






### Outgoing calls

For outgoing calls from a telephone, a line unit is seized when the telephone goes off-hook, placing a low-resistance loop across the tip and ring leads towards the NT1R20 OPS analog line card (see Table 69 on [page 170](#)). When the card detects the low-resistance loop, it prepares to receive digits. When the system is ready to receive digits, it returns a dial tone. Outward address signaling is then applied from the telephone in the form of loop (interrupting dial pulses or DTMF tones).

**Table 69**  
**Call connection sequence—near-end station receiving call (Part 1 of 2)**

State	Signal / Direction Far-end / Near-end	Remarks
Line card unit idle	Group on tip, battery on ring High resistance loop	No battery current drawn.
Call request	Low resistance loop  	Near-end station goes off-hook. Battery current is drawn, causing detection of off-hook state.
	Dial Tone  	Dial tone is applied to the near end station from the system.

**Table 69**  
**Call connection sequence—near-end station receiving call (Part 2 of 2)**

<b>State</b>	<b>Signal / Direction Far-end / Near-end</b>	<b>Remarks</b>
Outpulsing	Addressing signals 	Near-end station dials number (loop pulsing or DTMF tones).
		The system detects start of dialing and remove dial tone.
	Ringback (or busy) 	The system decodes addressing, route calls, and supply ringback tone to near-end station if far-end is on-hook. (Busy tone is supplied if far-end is off-hook).
Two-way voice connection		When call is answered, ringback tone is removed, and call is put through to far-end station.
Near-end station hangs-up first	High resistance loop 	If near end station hangs-up first, the line card detects the drop in loop current.
Line card unit idle	Group on tip, battery on ring High resistance loop	Line card unit is ready for the next call.
Far end station hangs up first	High resistance loop 	If the far-end hangs-up first, the system detects disconnect signalling from the trunk. The person at the near-end recognizes the end of the call and hangs-up.
Line card unit idle	Ground on tip/battery on ring High resistance loop	Line card unit is ready for the next call.

## Connector pin assignments

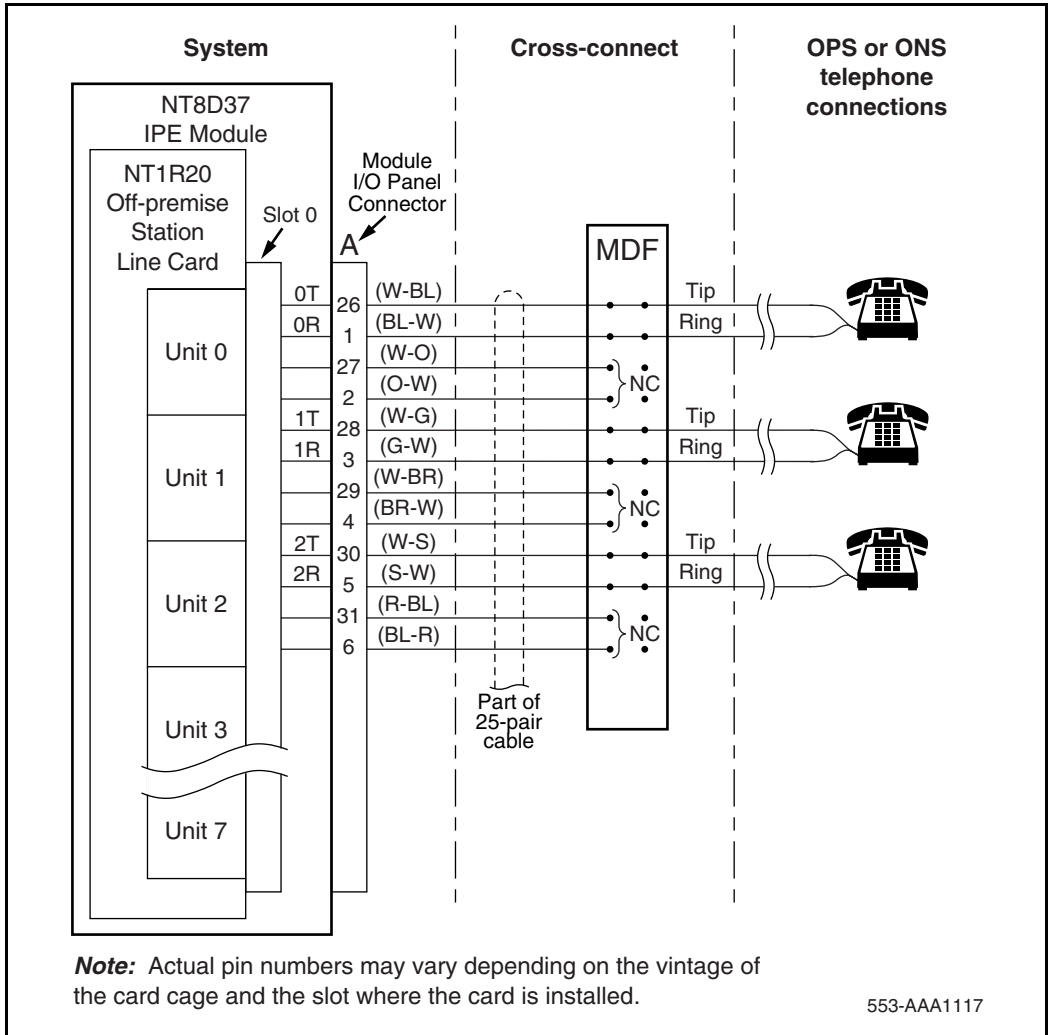
The OPS analog line card brings the eight analog telephone lines to the IPE backplane through a 160-pin connector shroud. The backplane is cabled to the input/output (I/O) panel on the rear of the module, which is then connected to the Main Distribution Frame (MDF) by 25-pair cables.

Telephone lines from station equipment cross connect to the OPS analog line card at the MDF using a wiring plan similar to that used for trunk cards. A typical connection example is shown in Figure 23 on [page 173](#), and a list of the connections to the analog line card is shown in Table 70. See *Communication Server 1000M and Meridian 1: Large System Installation and Configuration* (553-3021-210) for more detailed I/O panel connector information and wire assignments for each tip/ring pair.

**Table 70**  
**OPS analog line card – backplane pinouts**

Backplane Connector		Backplane Connector	
Pin	Signal	Pin	Signal
12A	Unit 0, Ring	12B	Unit 0, Tip
13A	Unit 1, Ring	13B	Unit 1, Tip
14A	Unit 2, Ring	14B	Unit 2, Tip
15A	Unit 3, Ring	15B	Unit 3, Tip
16A	Unit 4, Ring	16B	Unit 4, Tip
17A	Unit 5, Ring	17B	Unit 5, Tip
18A	Unit 6, Ring	18B	Unit 6, Tip
19A	Unit 7, Ring	19B	Unit 7, Tip

**Figure 23**  
**OPS analog line card – typical cross connection example**



## Configuring the OPS analog line card

The line type, terminating impedance, and balance network configuration for each unit on the card is selected by software service change entries at the system terminal and by jumper strap settings on the card.

### Jumper strap settings

Each line interface unit on the card is equipped with two jumper blocks that are used to select the proper loop current depending upon loop length. See Table 71.

For units connected to loops of 460 to 2300 ohms, both jumper blocks for that unit must have jumper blocks installed. For loops that are 460 ohms or less, jumper blocks are not installed. Figure 24 on [page 176](#) shows the location of the jumper blocks on the OPS analog line card.

**Table 71**  
**OPS analog line card – configuration (Part 1 of 2)**

Application	On-premise station (ONS)			Off-premise station (OPS)			
Class of Service (CLS) (Note 1)	ONP			OPX			
Loop resistance (ohms)	0–460			0–2300 (Note 2)			
Jumper strap setting (Note 6)	Both JX.0 and JX.1 off			Both JX.0 and JX.1 off		Both JX.0 and JX.1 on	
Loop loss (dB) (Note 3)	0–1.5	>0–3.0	>2.5–3.0	0–1.5	>1.5–2.5	>2.5–4.5	>4.5–15
TIMP (Notes 1, 4)	600 ohms	600 ohms	600 ohms	600 ohms	600 ohms	600 ohms	600 ohms
BIMP (Notes 1, 4)	600 ohms	3COM	3CM2	600 ohms	3COM	3CM2	3CM2

**Table 71**  
**OPS analog line card – configuration (Part 2 of 2)**

Application	On-premise station (ONS)	Off-premise station (OPS)									
Gain treatment (Note 5)	No										
<p><b>Note 1:</b> Configured in the Analog (500/2500-type) Telephone Administration program LD 10.</p> <p><b>Note 2:</b> The maximum signaling range supported by the OPS analog line card is 2300 ohms.</p> <p><b>Note 3:</b> Loss of untreated (no gain devices) metallic line facility. Upper loss limits correspond to loop resistance ranges for 26 AWG wire.</p> <p><b>Note 4:</b> The following are the default software impedance settings:</p> <table style="margin-left: auto; margin-right: auto;"> <thead> <tr> <th></th> <th style="text-align: center;"><u>ONP CLS</u></th> <th style="text-align: center;"><u>OPX CLS</u></th> </tr> </thead> <tbody> <tr> <td><b>Termination Impedance (TIMP):</b></td> <td style="text-align: center;">600 ohms</td> <td style="text-align: center;">600 ohms</td> </tr> <tr> <td><b>Balanced Impedance (BIMP):</b></td> <td style="text-align: center;">600 ohms</td> <td style="text-align: center;">3CM2</td> </tr> </tbody> </table> <p><b>Note 5:</b> Gain treatment, such as a Voice Frequency Repeater (VFR) is required to limit the actual OPS loop loss to 4.5 dB, maximum. VFR treatment of metallic loops having untreated loss greater than 15 dB (equivalent to a maximum signaling range of 2300 ohms on 26 AWG wire) is not recommended.</p> <p><b>Note 6:</b> Jumper strap settings JX.0 and JX.1 apply to all eight units; “X” indicates the unit number, 0 – 7. “Off” indicates that a jumper strap is not installed across both pins on a jumper block. Store unused straps on the OPS analog line card by installing them on a single jumper.</p>				<u>ONP CLS</u>	<u>OPX CLS</u>	<b>Termination Impedance (TIMP):</b>	600 ohms	600 ohms	<b>Balanced Impedance (BIMP):</b>	600 ohms	3CM2
	<u>ONP CLS</u>	<u>OPX CLS</u>									
<b>Termination Impedance (TIMP):</b>	600 ohms	600 ohms									
<b>Balanced Impedance (BIMP):</b>	600 ohms	3CM2									

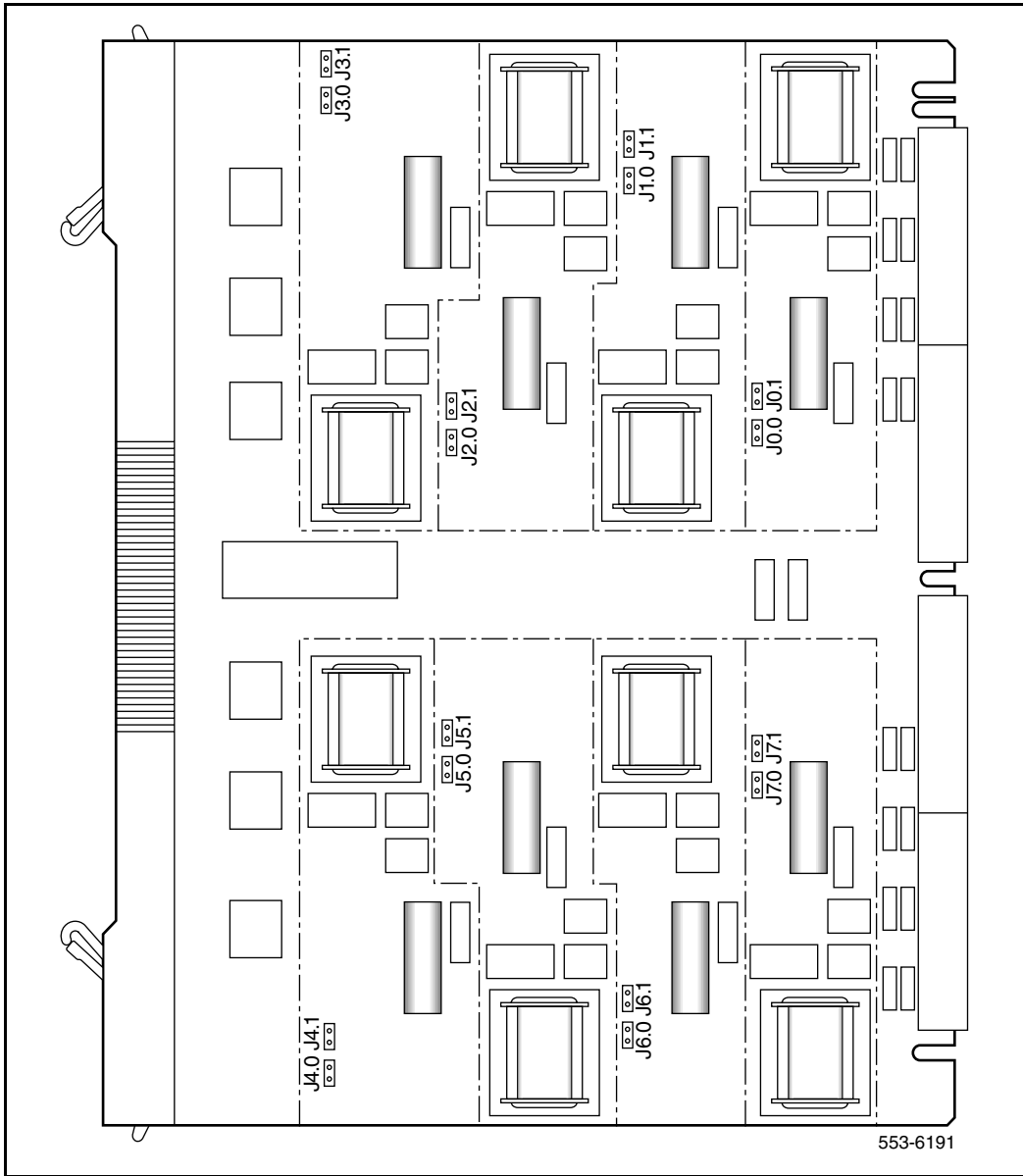
Before the appropriate balance network can be selected, the loop length between the near-end and the far-end station must be known. To assist in determining loop length, “Port-to-port loss” on [page 180](#) describes some typical resistance and loss values for the most common cable lengths for comparison with values obtained from actual measurements.

## Application

### Off-premise station application

The NT1R20 OPS analog line card is designed primarily to provide an interface for off-premise station lines. An OPS line serves a terminal – usually a telephone – remote from the PBX either within the same serving area as the

Figure 24  
OPS analog line card – jumper block locations

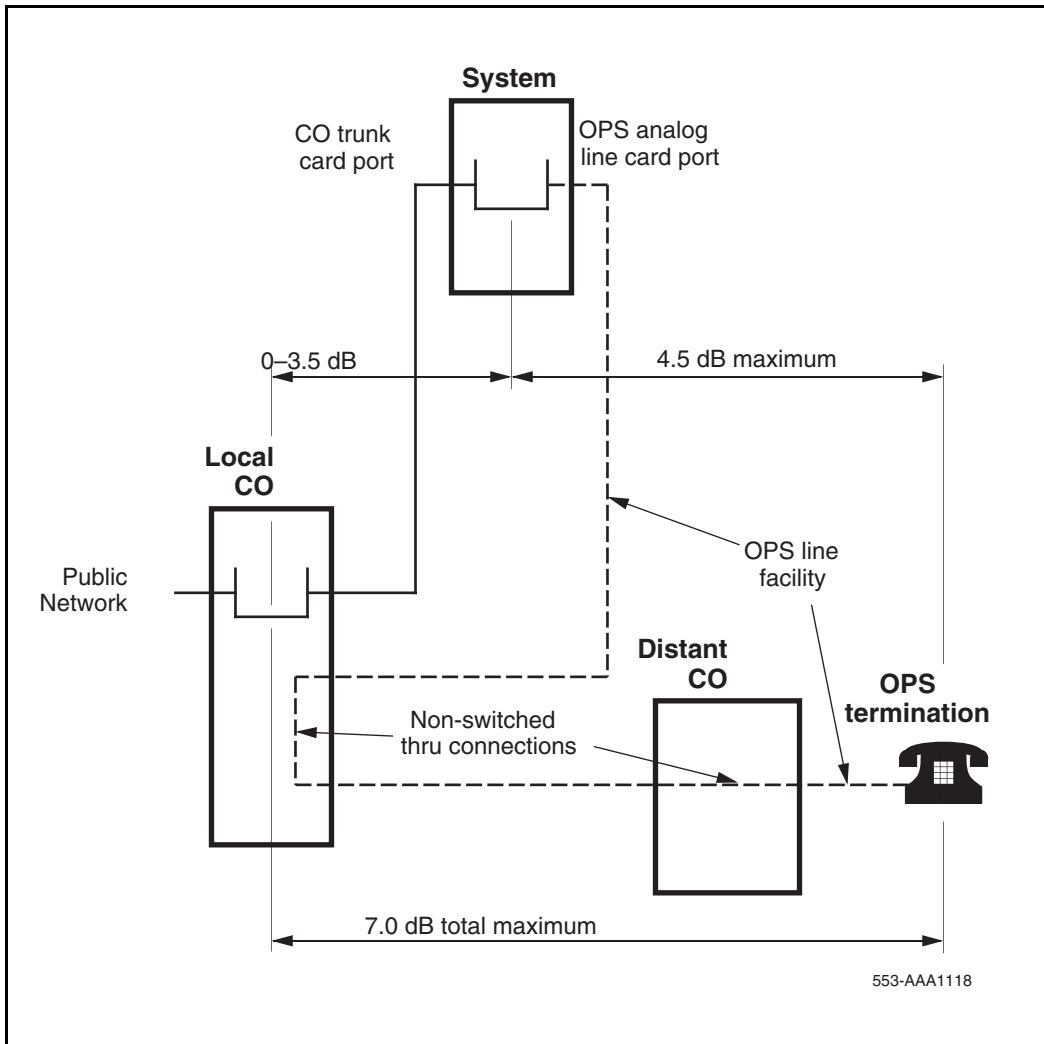




local office, or through a distant office. The line is not switched at these offices; however, depending on the facilities used, the local office serving the OPS station can provide line functions such as battery and ringing. Facilities are generally provided by the local exchange carrier (usually, OPS pairs are in the same cable as the PBX-CO trunks). The traditional OPS scenario configuration is shown in Figure 25 on [page 178](#).

**Note:** Do not confuse OPS service with Off-Premise Extension (OPX) service. OPX service is the provision of an extension to a main subscriber loop bridged onto the loop at the serving CO or PBX. Do not confuse CLS OPS (assigned in the Analog (500/2500-type) Telephone Administration program LD 10) with OPX, which denotes Off-Premise Extension service.

Figure 25  
Traditional OPS application configuration



## Other applications

The operating range and built-in protection provisions of the NT1R20 OPS analog line card make it suitable for applications which are variants on the traditional configuration shown in Figure 25 on [page 178](#). Examples of such applications are:

- a PBX in a central building serving stations in other buildings in the vicinity, such as in an industrial park, often called a campus environment. Facilities can be provided by the local exchange carrier or can be privately owned. Protection could be required.
- termination to other than a telephone, such as to a fax machine or a key telephone system.
- individual circuits on the NT1R20 OPS analog line card can also be configured as On-Premise Station (ONS) ports in LD 10:
  - to have ONS service with hazardous and surge voltage protection (not available on other analog line cards)
  - to use otherwise idle NT1R20 OPS analog line card ports

## Transmission considerations

The transmission performance of OPS lines depends on the following factors:

- the port-to-port loss for connections between OPS ports and other ports
- the transmission parameters of the facilities between the OPS port and the off-premise station or termination
- the electrical and acoustic transmission characteristics of the termination

These factors must be considered when planning applications using the NT1R20 OPS analog line card. They are important when considering configurations other than the traditional OPS application as shown in Figure 25 on [page 178](#). The following provides basic transmission planning guidelines for various OPS applications.

### Port-to-port loss

Loss is inserted between OPS analog line card ports and other ports in accordance with the loss plan. This plan determines the port-to-port loss for each call.

When a port is configured for CLS OPS, loss is programmed into the OPS analog line card on a call-by-call basis. When configured for CLS ONS, an OPS analog line card port is programmed to a value that is fixed for all calls. The loss in the other port involved in the call can vary on a call-by-call basis to achieve the total loss scheduled by the plan.

For satisfactory transmission performance, particularly on connections between the public network and an OPS termination, it is recommended that facilities conform to the following:

- Total 1 kHz loss from the local serving CO to the OPS terminal should not exceed 7.0 dB. The total loss in the facility between the PBX and the terminal must not exceed 4.5 dB. See Figure 25 on [page 178](#).

The following requirements are based on historic Inserted Connection Loss (ICL) objectives:

— PBX – CO trunk: 5 dB with gain; 0 – 4.0 dB without gain

— OPS line: 4.0 dB with gain; 0 – 4.5 dB without gain

Economic and technological changes have led to modifications of these objectives. But since the loss provisions in the PBX for OPS are constrained by regulatory requirements as well as industry standards, they are not designed to compensate for modified ICL designs in the connecting facilities.

- Nortel recommends that the attenuation distortion (frequency response) of the OPS facility be within  $\pm 3.0$  dB over the frequency range from 300 to 3000 Hz. It is desirable that this bandwidth extend from 200 to 3200 Hz.
- The terminating impedance of the facility at the OPS port be approximately that of 600 ohms cable.

If the OPS line facility loss is greater than 4.5 dB but does not exceed 15 dB, line treatment using a switched-gain Voice Frequency Repeater (VFR) will extend the voice range.

The overall range achievable on an OPS line facility is limited by the signaling range (2300 ohms loop including telephone resistance). The signaling range is unaffected by gain treatment; thus, gain treatment can be used to extend the voice range to the limit of the signaling range. For example, on 26 AWG wire, the signaling range of 2300 ohms corresponds to an untreated metallic loop loss of 15 dB. Gain treatment (such as a VFR) with 10.5 dB of gain would maintain the OPS service loss objective of 4.5 dB while extending the voice range to the full limit of the signaling range.

$$\begin{array}{rcl} & 15.0 \text{ dB} & \text{(loss corresponding to the maximum signaling range)} \\ - & 4.5 \text{ dB} & \text{(OPS service loss objective)} \\ \hline = & 10.5 \text{ dB} & \text{(required gain treatment)} \end{array}$$

The use of dial long line units to extend signaling range of OPS analog line cards beyond 15 dB is not recommended.

### **Termination transmission characteristics**

The loss plan for OPS connections is designed so that a connection with an OPS termination provides satisfactory end-to-end listener volume when the OPS termination is a standard telephone. The listener volume at the distant end depends on the OPS termination transmit loudness characteristics; the volume at the OPS termination end depends on the OPS termination receive loudness characteristics.

A feature of many (though not all) standard telephones is that the loudness increases with decreased current. Thus, as the line (PBX to OPS termination) facility gets longer and loss increases, the increased loudness of the telephone somewhat compensates for the higher loss, assuming direct current feed from the PBX with constant voltage at the feeding bridge. However, this compensation is not available when:

- the termination is a non-compensating telephone
- the OPS port is served by a line card using a constant-current feeding bridge
- the OPS termination is to telephones behind a local switch providing local current feed, such as a fax machine or a key telephone system

OPS line terminations with loudness characteristics designed for other applications can also impact transmission performance. For example, wireless portables loudness characteristics are selected for connections to switching systems for wireless communication systems; if used in an OPS arrangement without consideration for these characteristics, the result could be a significant deviation from optimum loudness performance.

---

# NT4N39AA CP Pentium IV Card

---

## Contents

This section contains information on the following topics:

<a href="#">Introduction</a> . . . . .	183
<a href="#">Physical description</a> . . . . .	183
<a href="#">Functional description</a> . . . . .	186
<a href="#">Front panel connector pin assignments</a> . . . . .	187

## Introduction

The NT4N39AA Call Processor Pentium IV (CP PIV) Large System processor card is introduced for CS 1000 Release 4.5. It features the following:

- a PCI-based design that is compatible with current CP PII architecture
- an Intel Pentium processor
- two Compact Flash (CF) sockets (one on-board and one hot-swappable on the faceplate). The on-board CF is referred to as the Fixed Media Disk (FMD), and the faceplate CF is referred to as the Removable Media Disk (RMD). See Figure 26 on [page 185](#) and Figure 27 on [page 186](#).
- 512 MBytes of Double Data Rate (DDR) memory

## Physical description

The NT4N39AA card measures 23 cm by 16 cm (9,2 in. by 6.3 in.). See Figure 26 on [page 185](#) and Figure 27 on [page 186](#).

The CP PIV front panel is equipped with an EMC gasket and two ejector/injector handles. A reset button and two double LED packages (four LEDs in total) are placed at the front panel as well. The front panel features the following:

- stacked dual standard DB9 Serial ports
- USB Connector
- stacked dual RJ-45 Ethernet ports with LEDs
- power good LED
- LEDs indication for activity on Compact flashes and secondary IDE interface
- reset Switch
- INI switch
- front panel handle part# 3688785, 3688784 (replacement for customer suggested parts 3686134, 3686135 which are now obsolete)



Figure 26  
CP PIV card (front)

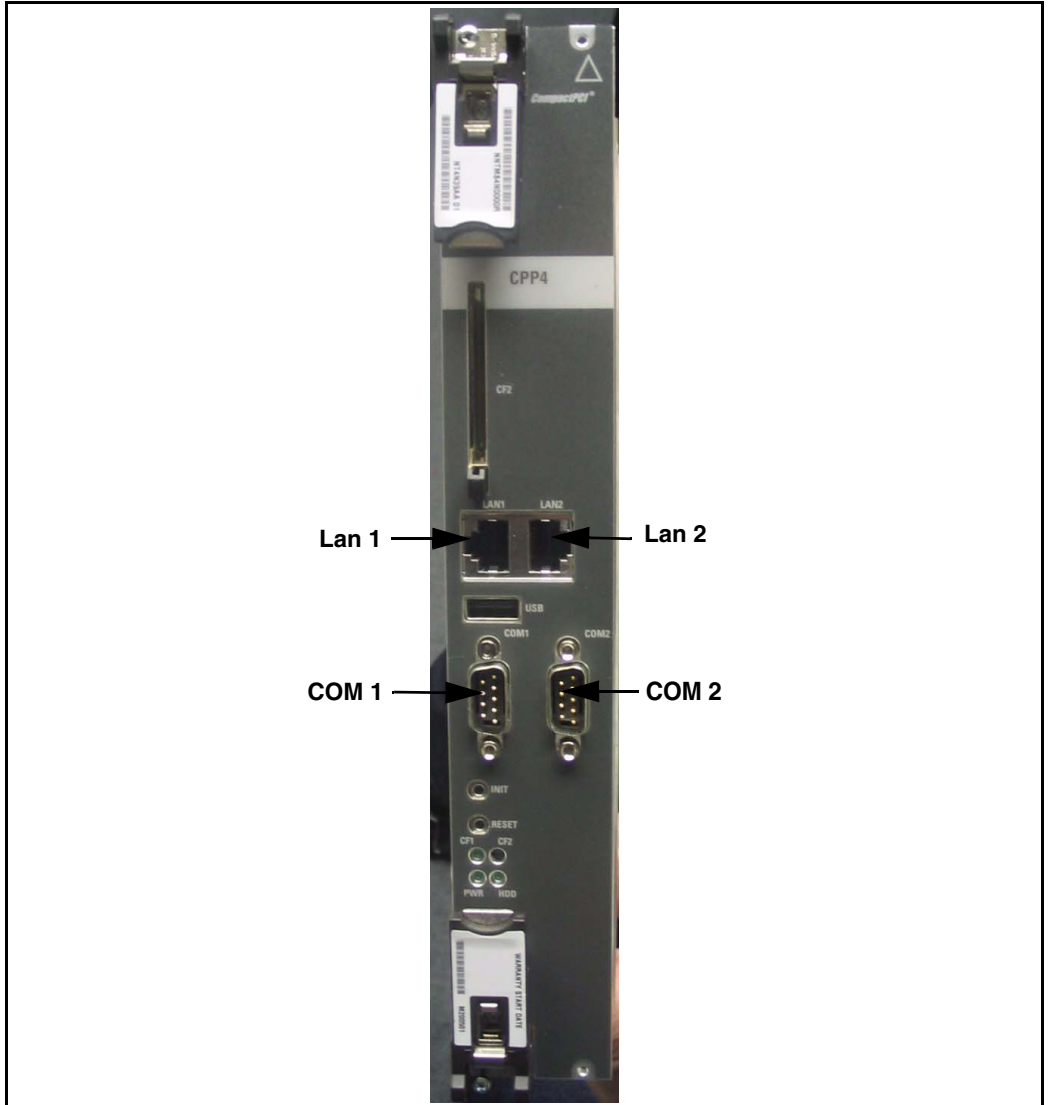
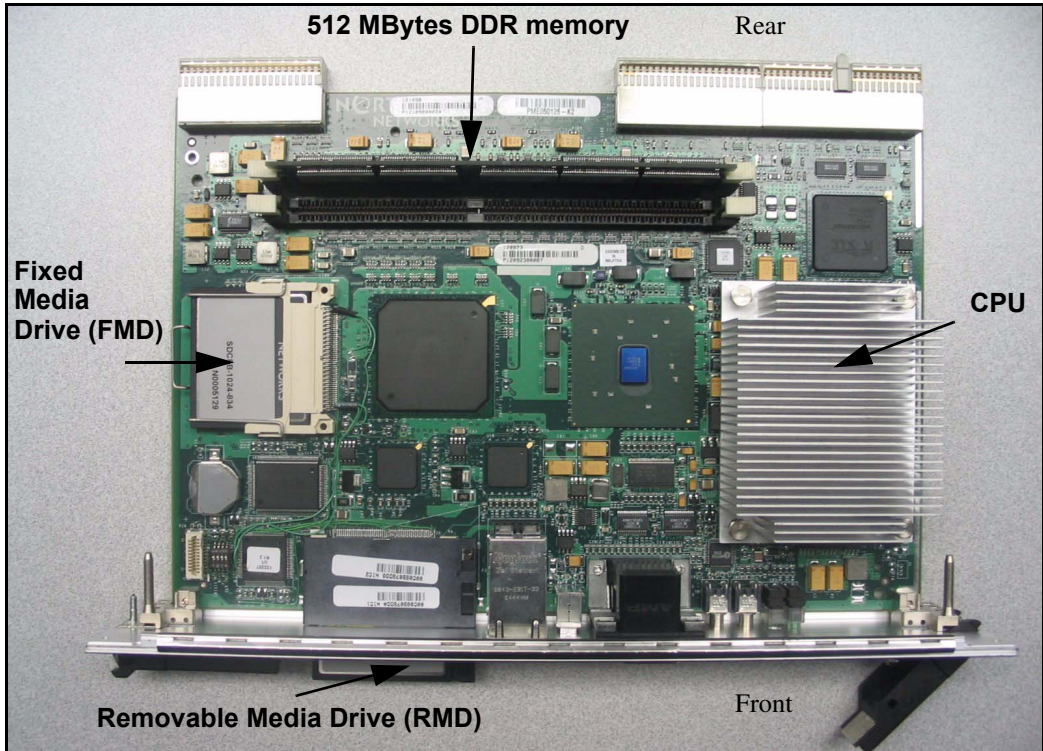


Figure 27  
CP PIV card (side)



## Functional description

The card employs an Intel Pentium Processor as the central processing unit. The internal core clock frequency reaches from 600MHz to 1.1GHz. The processor is manufactured in 0.09 um process technology and provides 32 KB of on die data and instruction cache as well as 1 MB of on die L2 cache running at core clock frequency. The processor is a mobile processor with a 478 pin FCBGA package with a maximum junction temperature of 100 °C. Processor power dissipation must not exceed 12 W.

The front side bus runs at 400 MHz and uses an AGTL+ signaling technology. The quad pumped data interface (data running at 4\*100 MHz = 400 MHz) is 64 bit wide providing a total bandwidth of 3.2 GBytes/s. The

double pumped address bus (addresses running at  $2 \times 100 \text{ MHz} = 200 \text{ MHz}$ ) is 32 bit wide supporting an address range of up to 4 GBytes. The processor voltage specification is compliant with IMVP IV specification.

## Memory

CP PIV memory uses DDR SDRAM technology. The CP PIV provides a maximum of two GBytes using two vertical DIMM sockets to install off-the-shelf DIMM modules. CP PIV only supports DDR SDRAM DIMM memory with a supply voltage of +2.5V.

The memory data path is 72-bit wide. The Intel 855GME Host Bridge supports 128 MByte, 256 MByte and 512 Mbyte SDRAM technologies with a maximum ROW page size of 16 Kbytes and CAS latency of 2 or 2.5. The maximum height of the DIMM modules possible on CP PIV is one inch or 25.4 mm.

The DDR interface runs at 100 MHz synchronously to the front side bus frequency. The SPD (Serial Presents Detect) -SRAM available on DIMM modules provide all necessary information (speed, size, and type) to the boot-up software. The SPD-SRAM can be read via SMBUS connected to the Intel Hance Rapids South Bridge.

## Front panel connector pin assignments

### COM1 and COM2 ports

The physical interface for the COM1 and COM2 ports to the front panel is through a stacked dual Male DB9 Connector. The corresponding pin details are shown in Table 72.

**Table 72**  
**COM1 and COM2 pin assignments**

Pin number	Pin name
1	DCD
2	RXD
3	TXD

**Table 72**  
**COM1 and COM2 pin assignments**

<b>4</b>	DTR
<b>5</b>	GND
<b>6</b>	DSR
<b>7</b>	RTS
<b>8</b>	CTS
<b>9</b>	RI

## USB port

The physical interface for the USB port to the front panel is through a standard USB connector. The corresponding Pin details are shown in Table 73.

**Table 73**  
**USB connector pin outs**

Pin number	Pin name
1	USB VCC
2	USB-
3	USB+
4	USB GND

## 10/100/1000 Mbps Ethernet ports

The physical interface for the two 10/100/1000 Mbps Ethernet ports to the front panel is through a stacked dual RJ 45 connector with magnetics and LEDs. The corresponding pin details are shown in Table 74.

**Table 74**  
**Ethernet connector pin outs**

Pin number	Pin name
1	AX+
2	AX-
3	BX+
4	CX+
5	CX-
6	BX-
7	DX+
8	DX-

## Front panel LED indicators

The CP PIV card has a total of five LEDs on the front panel which are 15 KV ESD protected and can be controlled via CPLD. Table 75 explains the function of each LED.

*Author's note: Are there 5 or 4?*

**Table 75**  
**Front panel LED functionality**

LED	Color	Functionality	Default
LED1	Green	Power ON LED	Off
LED2	Green	Secondary IDE HD activity	Off
LED3	Green	Compact Flash activity	Off
LED4	Green	Compact Flash activity	Off

## ITP connector (25 PIN, Debug Only)

**Figure 28**  
ITP connector pin outs

Pin	Signal Name	Pin	Signal Name
P1	GND	P2	GND
P3	BPM0N	P4	NC
P5	BPM1N	P6	RESETN
P7	BPM2N	P8	GND
P9	BPM3N	P10	TDI
P11	BPM4N	P12	TMS
P13	BPM5N	P14	TRSTN
P15	ITP_CPURSTN	P16	TCK
P17	TCK	P18	NC
P19	CLK	P20	GND
P21	CLKN	P22	PWR
P23	BPM5N	P24	TDO
P25	GND		

## Post 80 Debug LEDs (Optional)

CP PIV has post 80 debug LEDs to assist in debugging the board and solving boot related problems. Using a GPCS from Super I/O X-bus, data lines are latched using latch 74F374. These help identify Post 80 codes. This feature is available only in debug boards.





---

# NT5D11 and NT5D14 Lineside T1 Interface cards

---

## Contents

This section contains information on the following topics:

- Introduction . . . . . 193
- Physical description . . . . . 194
- Functional description . . . . . 198
- Electrical specifications . . . . . 202
- Installation and configuration . . . . . 204
- Man-Machine T1 maintenance interface software . . . . . 225
- Applications . . . . . 244

## Introduction

This section describes the two lineside T1 interface cards:

- NT5D11 – applicable for Large Systems only
- NT5D14 – applicable for Small Systems only

*Note:* Unless otherwise stated, the information in this section applies to both the NT5D11 and NT5D14 lineside T1 interface cards.

The NT5D11 lineside T1 Interface card is an intelligent 24-channel digital line card that is used to connect the switch to T1 compatible terminal equipment on the lineside. T1 compatible terminal equipment includes voice

mail systems, channel banks containing FXS cards, and key systems such as the Nortel Norstar. The lineside T1 card differs from trunk T1 cards in that it supports terminal equipment features such as hookflash, transfer, hold, and conference.

This card occupies two card slots in the main or expansion cabinets. The lineside T1 card can be installed in the system's main cabinet or one of the expansion cabinets (there are no limitations on the number of cards that can be installed in the Cabinet system).

The lineside T1 card emulates an analog line card to the system software; therefore, each channel is independently configurable by software control in LD 10. The lineside T1 card also comes equipped with a Man-Machine Interface (MMI) maintenance program. This feature provides diagnostic information regarding the status of the T1 link.

## Physical description

The lineside T1 card mounts into any two consecutive IPE slots. The card consists of a motherboard and a daughterboard. The motherboard circuitry is contained on a standard 31.75 by 25.40 cm. (12.5 by 10.0 in) printed circuit board. The daughterboard is contained on a 5.08 by 15.24 cm (2.0 by 6.0 in) printed circuit board and mounts to the motherboard on six standoffs.

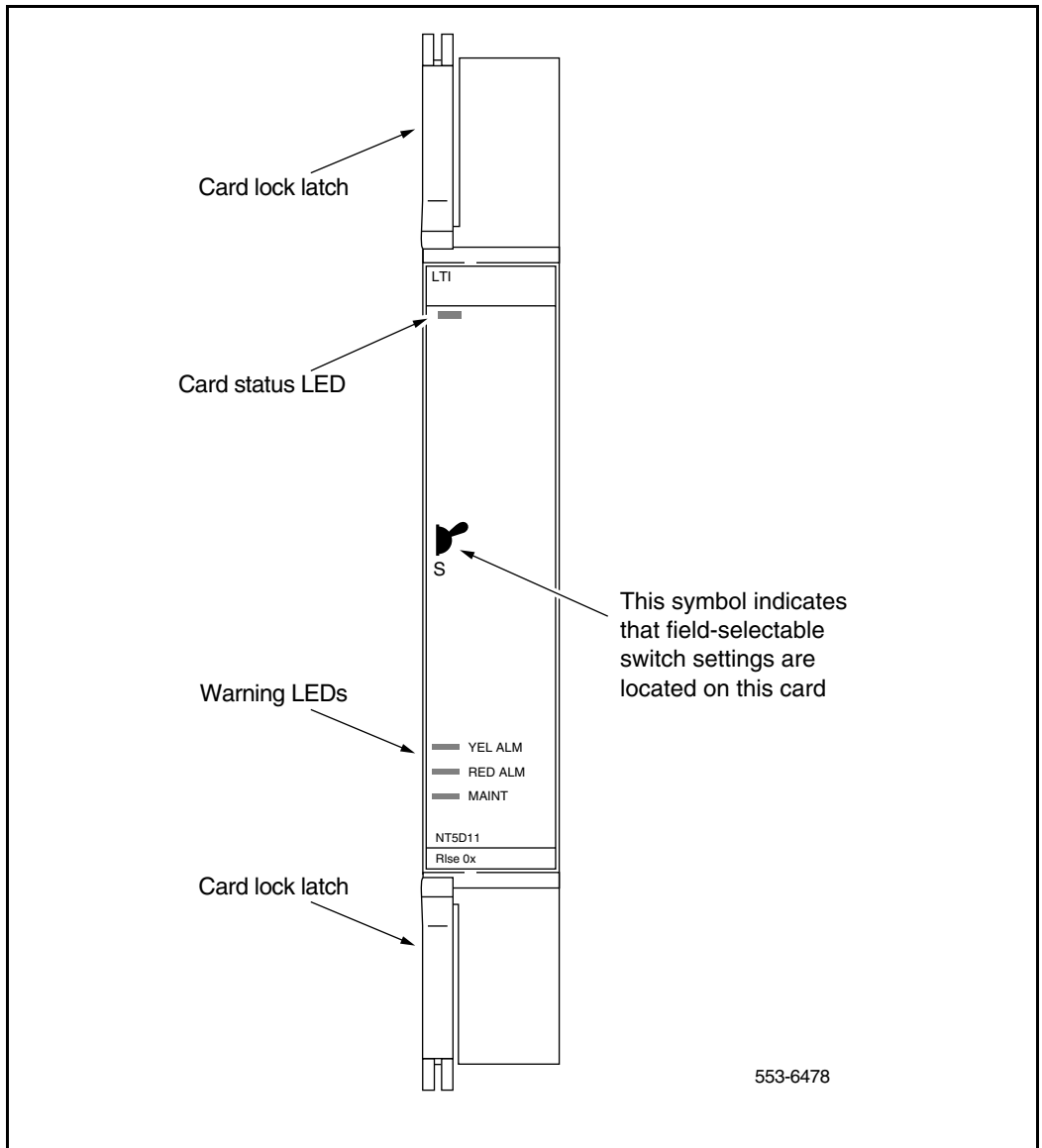
## Card connections

The lineside T1 card uses the NT8D81AA Tip and Ring cable to connect from the IPE backplane to the 25-pair amphenol connector on the IPE I/O input/output (I/O) panel. The I/O panel connector then connects directly to a T1 line, external alarm, and an MMI terminal or modem using the NT5D13AA lineside T1 I/O cable available from Nortel.

## Faceplate

The faceplate of the card is twice as wide as the other standard analog and digital line cards, and occupies two card slots. It comes equipped with four LED indicators. See Figure 29 on [page 195](#).

**Figure 29**  
**Lineside T1 card faceplate**



In general, the LEDs operate as shown in Table 76.

**Table 76**  
**NT5D14AA Lineside T1 faceplate LEDs**

LED	State	Definition
<b>STATUS</b>	On (Red)	The NT5D14AA card either failed its self-test or it hasn't yet been configured in software.
	Off	The card is in an active state.
<b>RED</b>	On (Red)	A red alarm has been detected from the T1 link. (This includes, but is not limited to: not receiving a signal, the signal has exceeded bit error thresholds or frame slip thresholds.)
	Off	No red alarm exists.
<b>YEL</b>	On (Yellow)	A yellow alarm state has been detected from the terminal equipment side of the T1 link. If the terminal equipment detects a red alarm condition, it may send a yellow alarm signal to the lineside T1 card (this depends on whether or not your terminal equipment supports this feature).
	Off	No yellow alarm.
<b>MAINT</b>	On (Red)	The card detects whether tests are being run or that alarms have been disabled through the Man-Machine Interface. The LED will remain lit until these conditions are no longer detected.
	Off	The lineside T1 card is fully operational.

The **STATUS** LED indicates that the lineside T1 card has successfully passed its self test, and is functional. When the card is installed, this LED remains lit for two to five seconds as the self-test runs. If the self-test completes successfully, the LED flashes three times and remains lit. When the card is configured and enabled in software, the LED goes out. If the LED flashes continuously, or remains weakly lit, replace the card.

**Note:** Note: The STATUS LED indicates the enabled/disabled status of both card slots of the lineside T1 card simultaneously. To properly enable the card, both the motherboard and the daughterboard slots must be enabled. The STATUS LED will turn off as soon as either one of the lineside T1 card slots have been enabled. No LED operation will be observed when the second card slot is enabled. To properly disable the card, both card slots must be disabled. The LED will not turn on until both card slots have been disabled.

The **RED ALARM** LED indicates that the lineside T1 card has detected an alarm condition from the T1 link. Alarm conditions can include such conditions as not receiving a signal or the signal has exceeded bit error thresholds or frame slip thresholds. See “Man-Machine T1 maintenance interface software” on [page 225](#) for information on T1 link maintenance.

If one of these alarm conditions is detected, this red LED will light. Yellow alarm indication is sent to the far-end as long as the near-end remains in a red alarm condition. Depending on how the Man-Machine Interface (MMI) is configured, this LED remains lit until the following actions occur:

- If the “Self-Clearing” function has been enabled in the MMI, the LED clears the alarm when the alarm condition is no longer detected. This is the factory default.
- If the “Self-Clearing” function has *not* been enabled or it has been subsequently disabled in the MMI, the LED will stay lit until the command “Clear Alarm” has been typed in the MMI, even though the carrier automatically returned to service when the alarm condition was no longer detected.

The **YELLOW ALARM** LED indicates that the lineside T1 card has detected a yellow alarm signal from the terminal equipment side of the T1 link. See the “Man-Machine T1 maintenance interface software” on [page 225](#) for information on T1 link maintenance. If the terminal equipment detects a red alarm condition, such as not receiving a signal or the signal has exceeded bit error thresholds or frame slip thresholds, it can send a yellow alarm signal to the lineside T1 card, depending on whether or not the terminal equipment supports this feature. If a yellow alarm signal is detected, this LED will light.

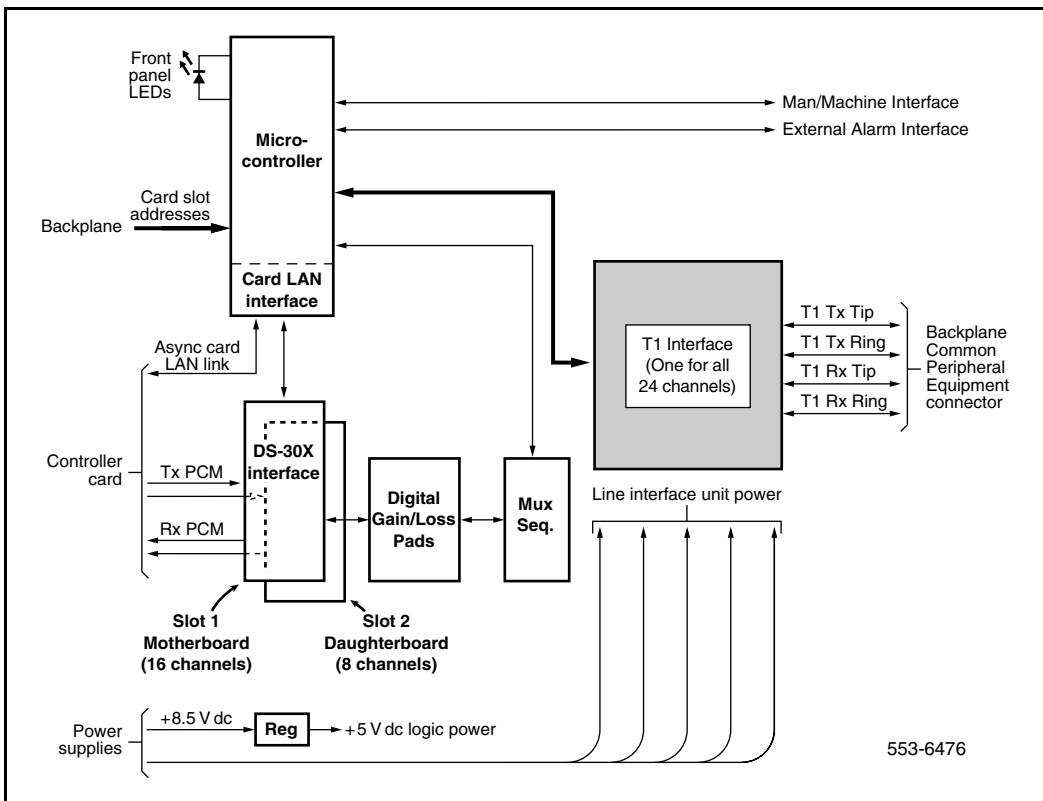
The **MAINT** LED indicates if the lineside T1 card is fully operational because of certain maintenance commands being issued through the MMI. See

“Man-Machine T1 maintenance interface software” on [page 225](#) for information on T1 link maintenance. If the card detects that tests are being run or that alarms have been disabled through the MMI, this LED will light and will remain lit until these conditions are no longer detected, then it will turn off.

## Functional description

Figure 30 shows a block diagram of the major functions contained on the lineside T1 card. Each of these functions is described on the following pages.

**Figure 30**  
**Lineside T1 card – block diagram**



The lineside T1 card is an IPE line card that provides a cost-effective all-digital connection between T1 compatible terminal equipment (such as voice mail systems, voice response units, and trading turrets) and the system. The terminal equipment is assured access to analog (500/2500-type) telephone type line functionality such as hook flash, SPRE codes and ringback tones generated from the switch. Usually, the lineside T1 card eliminates the need for channel bank type equipment normally placed between the switch and the terminal equipment. This provides a more robust and reliable end-to-end connection. The lineside T1 card supports line supervision features such as loop and ground start protocols. It can also be used in an off-premise arrangement where analog (500/2500-type) telephones are extended over T1 with the use of channel bank equipment.

The lineside T1 interface offers significant improvement over the previous alternatives. For example, if a digital trunk connection were used, such as with the DTI/PRI interface card, lineside functionality would not be supported. Previously, the only way to achieve the lineside functionality was to use analog ports and channel bank equipment. No channel bank equipment is required, resulting in a more robust and reliable connection.

The lineside T1 interface offers a number of benefits when used to connect to third-party applications equipment:

- It is a more cost-effective alternative for connection because it eliminates the need for expensive channel bank equipment.
- The lineside T1 supports powerful T1 monitoring and diagnostic capability.
- Overall costs for customer applications can also be reduced because the T1-compatible IPE is often more attractively priced than the analog-port alternatives.

The lineside T1 card is compatible with all IPE based systems and standard public or private DSX-1 type carrier facilities. Using A/B robbed bit signaling, it supports D4 or ESF channel framing formats as well as AMI or B8ZS coding. Because it uses standard PCM in standard T1 timeslots, existing T1 test equipment remains compatible for diagnostic and fault isolation purposes.

## Card interfaces

The lineside T1 card passes voice and signaling data over DS-30X loops through the DS-30X Interfaces circuits and maintenance data over the card LAN link.

## T1 interface circuit

The lineside T1 card contains one T1 line interface circuit which provides 24 individually configurable voice interfaces to one T1 link in 24 different time slots. The circuit demultiplexes the 2.56 Mbps DS-30X Tx signaling bitstreams from the DS-30X network loop and converts it into 1.544 MHz T1 Tx signaling bitstreams onto the T1 link. It also does the opposite, receiving Rx signaling bitstreams from the T1 link and transmitting Rx signaling bitstreams onto the DS-30X network loop.

The T1 interface circuit performs the following:

- Provides an industry standard DSX-1 (0 to 655 ft./200 meters) interface.
- Converts DS-30X signaling protocol into FXO A and B robbed bit signaling protocol.
- Provides switch-selectable transmission and reception of T1 signaling messages over a T1 link in either loop or ground start mode.

## Signaling and control

The lineside T1 card also contains signaling and control circuits that establish, supervise, and take down call connections. These circuits work with the system controller to operate the T1 line interface circuit during calls. The circuits receive outgoing call signaling messages from the controller and return incoming call status information to the controller over the DS-30X network loop.

## Card control functions

Control functions are provided by a microcontroller and a Card LAN link on the lineside T1 card. A sanity timer is provided to automatically reset the card if the microcontroller stops functioning for any reason.



## Microcontrollers

The lineside T1 card contains a microcontroller that controls the internal operation of the card and the serial card LAN link to the controller card. The microcontroller controls the following:

- reporting to the CPU via the card LAN link:
  - card identification (card type, vintage, serial number)
  - firmware version
  - self-test results
  - programmed unit parameter status
- receipt and implementation of card configuration:
  - control of the T1 line interface
  - enabling/disabling of individual units or entire card
  - programming of loop interface control circuits for administration of channel operation
  - maintenance diagnostics
- interface with the line card circuit:
  - converts on/off-hook, and ringer control messages from the DS-30X loop into A/B bit manipulations for each time slot in the T1 data stream, using robbed bit signaling.
- the front panel LED when the card is enabled or disabled by instructions from the NT8D01 controller card.

## Card LAN interface

Maintenance data is exchanged with the CPU over a dedicated asynchronous serial network called the Card LAN link.

## Sanity timer

The lineside T1 card also contains a sanity timer that resets the microcontroller in the event of a loss of program control. The microcontroller must service the sanity timer every 1.2 seconds. If the timer is not properly serviced, it times out and causes the microcontroller to be hardware reset.

### Man-Machine Interface

The lineside T1 card provides an optional Man-Machine Interface (MMI) that is primarily used for T1 link performance monitoring and problem diagnosis. The MMI provides alarm notification, T1 link performance reporting and fault isolation testing. The interface is accessed through connections from the I/O panel to a terminal or modem.

The MMI is an optional feature since all T1 configuration settings are performed through dip switch settings or preconfigured factory default settings.

## Electrical specifications

### T1 channel specifications

Table 77 provides specifications for the 24 T1 channels. Each characteristic is configured by dip switches.

**Table 77**  
**Lineside T1 card – line interface unit electrical characteristics**

Characteristics	Description
Framing	ESF or D4
Coding	AMI or B8ZS
Signaling	Loop or ground start A/B robbed-bit
Distance to Customer Premise Equipment (CPE) or Channel Service Unit	0-199.6 meters (0–655 feet)

## Power requirements

The lineside T1 card requires +15 V, -15 V, and +5 V from the backplane. One NT8D06 IPE Power Supply AC or NT6D40 IPE Power Supply DC can supply power to a maximum of eight lineside T1 cards. See Table 78.

**Table 78**  
**Lineside T1 card – power required**

<b>Voltage</b>	<b>Current (max.)</b>
+ 5.0 V dc	1.6 Amp
+15.0 V dc	150 mA.
-15.0 V dc	150 mA.

## Foreign and surge voltage protections

In-circuit protection against power line crosses or lightning is not provided on the lineside T1 card. It does have protection against accidental shorts to -52 V dc analog lines.

When the card is used to service off-premise terminal equipment through the public telephone network, install a Channel Service Unit (CSU) as part of the terminal equipment to provide external line protection.

## Environmental specifications

Table 79 lists the environmental specifications of the lineside T1 card.

**Table 79**  
**Lineside T1 card – environmental specifications**

Parameter	Specifications
Operating temperature-normal	15° to +30° C (+59° to 86°F), ambient
Operating temperature-short term	10° to +45° C (+50° to 113°F), ambient
Operating humidity-normal	20% to 55% RH (non-condensing)
Operating humidity-short term	20% to 80% RH (non-condensing)
Storage temperature	–50° to +70° C (–58° to 158°F), ambient
Storage humidity	5% to 95% RH (non-condensing)

## Installation and configuration

Installation and configuration of the lineside T1 card consists of six basic steps:

- 1** Configure the dip switches on the lineside T1 card for the environment.
- 2** Install the lineside T1 card into the selected card slots in the IPE shelf.
- 3** Cable from the I/O panel to the Customer Premise Equipment (CPE) or CSU, MMI terminal or modem (optional), external alarm (optional), and other lineside T1 cards for daisy chaining use of MMI terminal (optional).
- 4** Configure the MMI terminal.
- 5** Configure the lineside T1 card through the system software and verify self-test results.
- 6** Verify initial T1 operation and configure MMI (optional).

Steps 1-5 are explained in this section. Step 6 is covered in “Man-Machine T1 maintenance interface software” on [page 225](#).

## Dip switch settings

Begin the installation and configuration of the lineside T1 card by selecting the proper dip switch settings for the environment. The lineside T1 card contains two dip switches, each containing eight switch positions. They are located in the upper right corner of the motherboard circuit card as shown in Figure 31 on [page 206](#). The configuration for these switches are shown in Tables 80 through 83.

When the line-side T1 card is oriented as shown in Figure 31 on [page 206](#), the dip switches are ON when they are up, and OFF when they are down. The dip switch settings configure the card for the following parameters:

### MMI port speed selection

This dip switch setting selects the appropriate baud rate for the terminal or modem (if any) that is connected to the MMI.

### Line Supervisory Signaling protocol

As described in “Lineside T1 call operation” on [page 46](#), the lineside T1 card is capable of supporting loop start or ground start call processing modes. Make the selection for this dip switch position based on what type of line signaling the CPE equipment supports.

### Address of lineside T1 card to the MMI

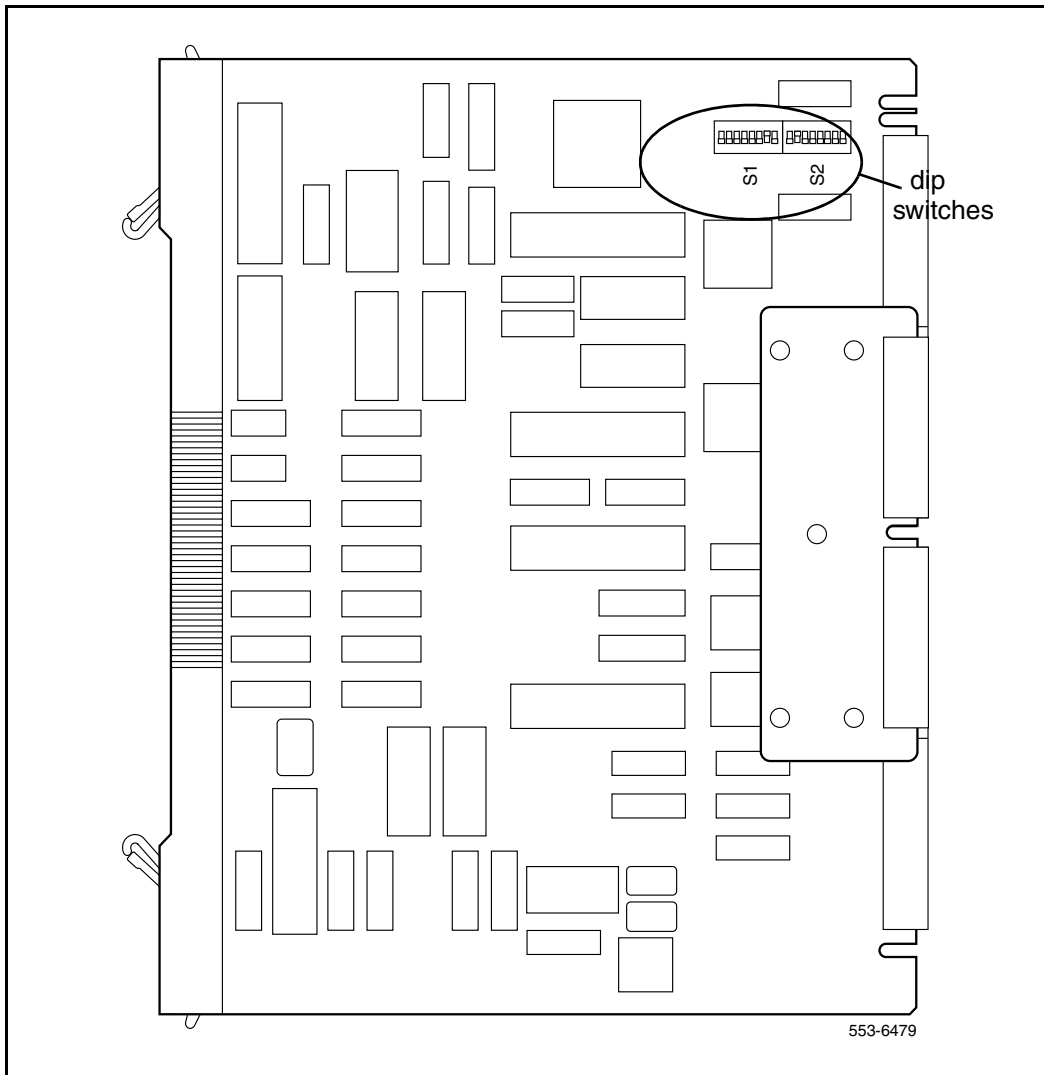
The address of the lineside T1 card to the MMI is made up of two components:

- The address of the card within the shelf
- The address of the shelf in which the card resides

These two addresses are combined to create a unique address for the card. The MMI reads the address of the card within the shelf from the card firmware; however the address of the shelf must be set by this dip switch.

The shelf address dip switch can be from 0 – 15. 16 is the maximum number of lineside T1 IPE shelves (a maximum of 64 lineside T1 cards) capable of daisy chaining to a single MMI terminal. For ease, it is recommended that this address be set the same as the address of the peripheral controller identifier in

**Figure 31**  
**Lineside T1 card – T1 protocol dip switch locations**



LD 97 for type: XPE. However, this is not mandatory, and, since the dip switch is limited to 16, this will not always be possible.

**T1 framing**

The lineside T1 card is capable of interfacing with CPE or CSU equipment either in D4 or ESF framing mode. Make the selection for this dip switch position based on what type of framing the CPE or CSU equipment supports.

**T1 coding**

The lineside T1 card is capable of interfacing with CPE or CSU equipment using either AMI or B8ZS coding. Make the selection for this dip switch position based on what type of coding the CPE or CSU equipment supports.

**DSX-1 length**

Estimate the distance between the lineside T1 card and the hardwired local CPE, or the Telco demarc RJ48, for the carrier facility connecting the lineside T1 and the remote CPE. Make the selection for this dip switch position based on this distance.

**Line supervision on T1 failure**

This setting determines in what state all 24 ports of the lineside T1 card appears to the CS 1000S, CS 1000M, and Meridian 1 in case of T1 failure. Ports can appear as either in the on-hook or off-hook states on T1 failure.

*Note:* All idle lineside T1 lines will go off-hook and seize a Digitone Receiver when the off-hook line processing is invoked on T1 failure. This may prevent DID trunks from receiving incoming calls until the lineside T1 lines time-out and release the DTRs.

**Daisy-chaining to MMI**

If two or more lineside T1 cards are installed and the MMI is used, daisy-chain the cards together to use one MMI terminal or modem, See Figure 33 on [page 221](#). Make the selection for this dip switch position based on how many lineside T1 cards will be installed.

**MMI master or slave**

This setting is used only if daisy-chaining the cards to the MMI terminal or modem. This setting determines whether this card is a master or a slave in the MMI daisy-chain. Select the master setting if this card is the card that is

cabled directly into the MMI terminal or modem; select the slave setting if this card is cabled to another lineside T1 card in a daisy chain.

Tables 80 through 83 describes the proper dip switch settings for each type of T1 link. After the card has been installed, the MMI displays the DIP switch settings the command **Display Configuration** is used. See “Man-Machine T1 maintenance interface software” on [page 225](#) for details on how to invoke this command.

**Table 80**  
**Lineside T1 card—T1 Switch 1 (S1) dip switch settings**

Dip Switch Number	Characteristic	Selection
1	MMI port speed selection	On = 1200 baud Off = 2400 baud
2	T1 signaling	On = Ground start Off = Loop start
3–6	XPEC Address for the lineside T1 card	See Table 81
7	Not Used	Leave Off
8	Reserved for SL-100 use	Leave Off

**Table 81**  
**Lineside T1 card – XPEC address dip switch settings (Switch S1, positions 3 – 6)**  
**(Part 1 of 2)**

XPEC Address	S1 Switch Position 3	S1 Switch Position 4	S1 Switch Position 5	S1 Switch Position 6
00	Off	Off	Off	Off
01	Off	Off	Off	On
02	Off	Off	On	Off
03	Off	Off	On	On
04	Off	On	Off	Off



**Table 81**  
**Lineside T1 card – XPEC address dip switch settings (Switch S1, positions 3 – 6)**  
**(Part 2 of 2)**

XPEC Address	S1 Switch Position 3	S1 Switch Position 4	S1 Switch Position 5	S1 Switch Position 6
05	Off	On	Off	On
06	Off	On	On	Off
07	Off	On	On	On
08	On	Off	Off	Off
09	On	Off	Off	On
10	On	Off	On	Off
11	On	Off	On	On
12	On	On	Off	Off
13	On	On	Off	On
14	On	On	On	Off
15	On	On	On	On

**Table 82**  
**Lineside T1 card – T1 Switch 2 (S2) dip switch settings (Part 1 of 2)**

Dip Switch Number	Characteristic	Selection
1	T1 framing	On = D4 Off = ESF
2	T1 Coding	On = AMI Off = B8ZS
3–5	CPE or CSU distance	See Table 83 on <a href="#">page 210</a>
6	Line processing on T1 link failure	On = On-hook Off = Off-hook

**Table 82**  
**Lineside T1 card – T1 Switch 2 (S2) dip switch settings (Part 2 of 2)**

Dip Switch Number	Characteristic	Selection
7	Daisy-chaining to MMI	On = Yes Off = No
8	MMI Master or Slave	On = Master Off = Slave

**Table 83**  
**Lineside T1 card – CPE or CSU distance dip switch settings (Switch S2, positions 3 – 5)**

Distance	S2 Switch Position 3	S2 Switch Position 4	S2 Switch Position 5
0–133	On	Off	Off
134–266	Off	On	On
267–399	Off	On	Off
400–533	Off	Off	On
534–655	Off	Off	Off

## Installation

This section describes how to install and test the lineside T1 card.

When installed, the lineside T1 card occupies two card slots. It can be installed into an NT8D37 IPE module.

When installing the lineside T1 card into NT8D37 IPE module, determine the vintage level module. If the 25-pair I/O connectors are partially split between adjacent IPE card slots, the lineside T1 card works only in card slots where Unit 0 of the motherboard card slot appears on the first pair of the 25-pair I/O connector.

Certain vintage levels have dedicated 25-pair I/O connectors only for card slots 0, 4, 8, and 12. These vintage levels are cabled with only 16 pairs of wires from each card slot to the I/O panel. Some of the 25-pair I/O connectors are split between adjacent card slots. Other vintage levels cable each card slot to the I/O panel using a unique, 24-pair connector on the I/O panel. In these vintage levels, the lineside T1 card can be installed in any available pair of card slots. However, because of the lower number of wire pairs cabled to the I/O panel in the lower vintage level, only certain card slots are available to the lineside T1 card.

See Table 84 for the vintage level information for the NT8D37 IPE modules.

**Table 84**  
**Lineside T1 card – NT8D37 IPE module vintage level port cabling**

<b>Vintage Level</b>	<b>Number of ports cabled to I/O panel</b>
NT8D37AA	16 ports
NT8D37BA	24 ports
NT8D37DC	16 ports
NT8D37DE	16 ports
NT8D37EC	24 ports

***Vintage levels cabling 24 ports***

For modules with vintage levels that cabled 24 ports to the I/O panel, the lineside T1 card can be installed in any pair of card slots 015.

### ***Vintage levels cabling 16 ports***

For modules with vintage levels that cabled 16 ports to the I/O panel, the lineside T1 card can be installed into the following card slot pairs:

Available:	Motherboard/Daughterboard
	0 and 1
	1 and 2
	4 and 5
	7 and 8
	8 and 9
	9 and 10
	12 and 13
	13 and 14

The lineside T1 card cannot be installed into the following card slot pairs:

Restricted:	Motherboard/Daughterboard
	2 and 3
	3 and 4
	6 and 7
	10 and 11
	11 and 12
	14 and 15

If the lineside T1 card must be installed into one of the restricted card slot pairs, rewire the IPE module card slot to the I/O panel by installing an additional NT8D81 cable from the lineside T1 card motherboard slot to the I/O panel. Re-arrange the three backplane connectors for the affected card slots. This will permit the connection of the NT5D13AA lineside T1 card carrier and maintenance external I/O cable at the IPE module I/O panel connector for card slots that are otherwise restricted.

Also, all lineside T1 card connections can be made at the main distribution frame instead of connecting the NT5D13 lineside T1 card external I/O cable at the I/O panel. This eliminates these card slots restrictions.

## **Cabling the lineside T1 card**

After configuring the dip switches and installing the lineside T1 card into the selected card slots, the lineside T1 card is ready to be cabled to the CPE or CSU equipment. Connections can also be made to the MMI terminal or modem (optional), an external alarm (optional), and other lineside T1 cards for daisy-chain use of the MMI terminal (optional).

The lineside T1 card is cabled from its backplane connector through connections from the motherboard circuit card only (no cable connections are made from the daughterboard circuit card) to the input/output (I/O) panel on the rear of the IPE module. The connections from the lineside T1 card to the I/O panel are made with the NT8D81AA Tip and Ring cables provided with the IPE module.

### **Cabling from the I/O panel with the NT5D13AA lineside T1 I/O cable**

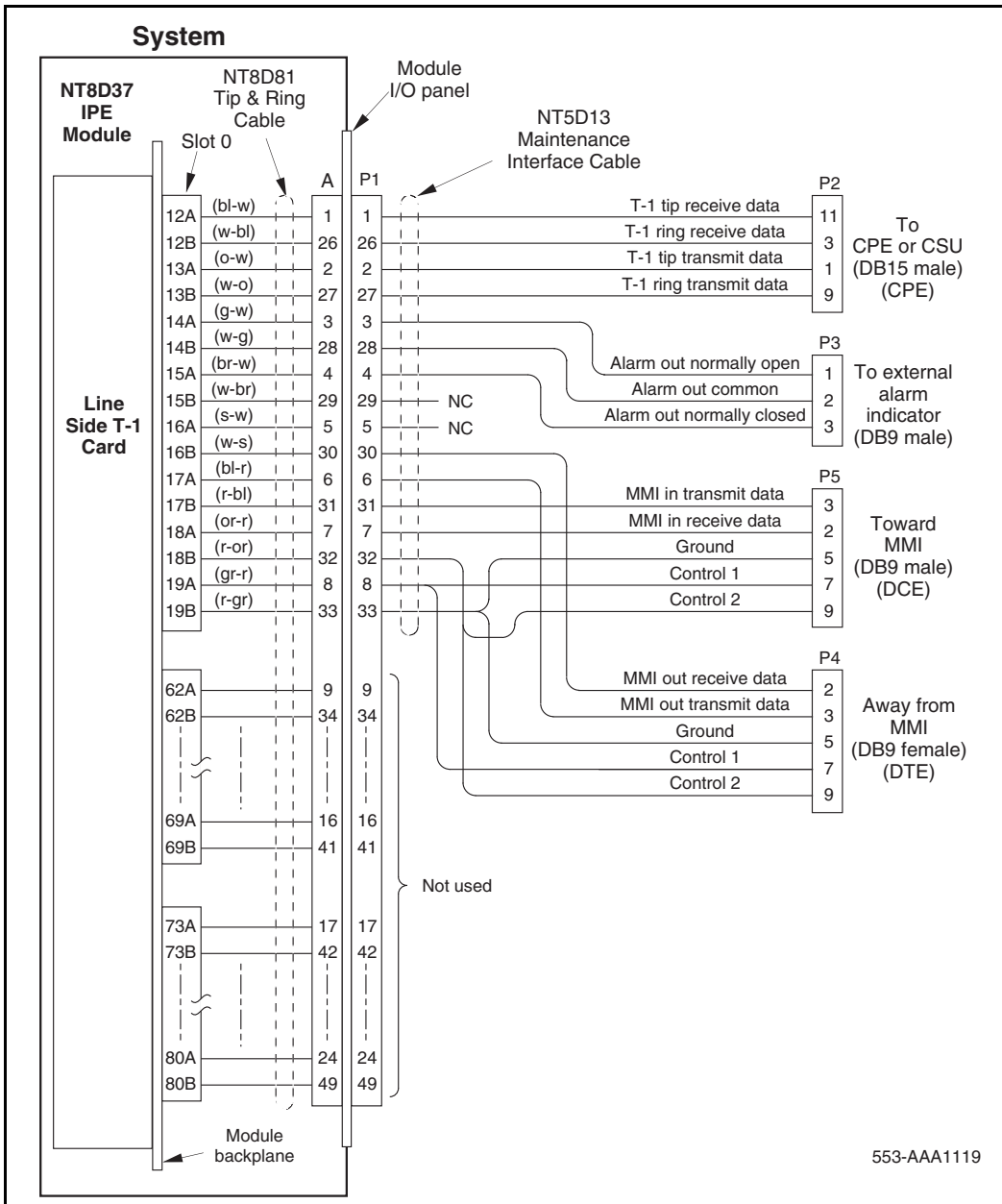
Usually, the I/O panel is connected to the T1 link and other external devices through the NT5D13AA lineside T1 I/O cable. See Figure 32 on [page 214](#). This cable consists of a 25-pair amphenol connector (P1) on one end which plugs into the I/O panel. The other end has 4 connectors:

- 1** a DB15 male connector (P2) which plugs into the T1 line
- 2** a DB9 male connector (P3) which plugs into an external alarm system
- 3** a second DB9 male connector (P5) which connects to an MMI terminal or modem
- 4** a DB9 female connector (P4) that connects to the next lineside T1 card's P4 connector for MMI daisy chaining

### **Cabling from the I/O panel at the Main Distribution Frame**

All lineside T1 connections can be made at the main distribution frame (MDF) if it is preferred to not use the NT5D13AA lineside T1 I/O cable at the I/O panel.

**Figure 32**  
**Lineside T1 card – connection using the NT5D13AA lineside T1 cable**



**Procedure 11**  
**Connecting to the MDF**

To make the connections at the MDF, follow this procedure:

- 1 Punch down the first eight pairs of a standard telco 25-pair female-connectorized cross-connect tail starting with the first tip and ring pair of the lineside T1 motherboard card slot on the cross-connect side of the MDF terminals.
- 2 Plug the NT5D13AA lineside T1 I/O cable into this 25-pair cross-connect tail at the MDF, regardless of the card slot restrictions that exist from the vintage level of IPE or CE module used. This connection can also be made at the MDF without using the NT5D13 lineside T1 I/O cable, by cross-connecting according to the pinouts in Table 85.
- 3 Turn over the T1 transmit and receive pairs, where required for hardwiring the lineside T1 card to local CPE T1 terminal equipment.

**End of Procedure**

The backplane connector is arranged as an 80-row by 2-column array of pins. Table 85 shows the I/O pin designations for the backplane connector and the 25-pair Amphenol connector from the I/O panel. Although the connections from the I/O panel only use 14 of the available 50 pins, the remaining pins are reserved and cannot be used for other signaling transmissions.

The information in Table 85 is provided as a reference and diagnostic aid at the backplane, since the cabling arrangement can vary at the I/O panel. See *Communication Server 1000M and Meridian 1: Large System Installation and Configuration* (553-3021-210) for cable pinout information for the I/O panel.

**Table 85**  
**Lineside T1 card – backplane pinouts (Part 1 of 2)**

Backplane Connector Pin	I/O Panel Connector Pin	Signal
12A	1	T1 Tip, Receive Data
12B	26	T1 Ring, Receive Data

**Table 85**  
**Lineside T1 card – backplane pinouts (Part 2 of 2)**

<b>Backplane Connector Pin</b>	<b>I/O Panel Connector Pin</b>	<b>Signal</b>
13A	2	T1 Tip, Transmit Data
13B	27	T1 Ring, Transmit Data
14A	3	Alarm out, Normally open
14B	28	Alarm out, Common
15A	4	Alarm out, Normally closed
15B	29	No Connection
16A	5	No Connection
16B	30	Away from MMI terminal, Receive Data
17A	6	Away from MMI terminal, Transmit Data
17B	31	Towards MMI terminal, Transmit Data
18A	7	Towards MMI terminal, Receive Data
18B	32	Daisy-chain Control 2
19A	8	Daisy-chain Control 1
19B	33	Ground



Table 86 shows the pin assignments when using the NT5D13AA lineside T1 I/O cable.

**Table 86**  
**Lineside T1 card – NT5D13AA connector pinouts (Part 1 of 2)**

<b>I/O panel connector pin</b>	<b>Lead designations</b>	<b>NT5D13AA Lineside T1 I/O connector pin</b>	<b>Lineside T1 cable connector to external equipment</b>
1	T1 Tip Receive Data	11	DB15 male to T1 (P2) Lineside T1 card is CPE transmit to network and receive from network
26	T1 Ring Receive Data	3	
2	T1 Tip Transmit Data	1	
27	T1 Ring Transmit Data	9	
3	Alarm out common	1	DB9 male to external alarm (P3)
28	Alarm out (normally open)	2	
4	Alarm out (normally closed)	3	
7	Towards MMI terminal Receive Data	2	DB9 male towards MMI (P5) Wired as DCE Data is transmitted on pin 2 (RXD) and received on pin 3 (TXD)
31	Towards MMI terminal Transmit Data	3	
33	Ground	5	
8	Control 1	7	
32	Control 2	9	

**Table 86**  
**Lineside T1 card – NT5D13AA connector pinouts (Part 2 of 2)**

I/O panel connector pin	Lead designations	NT5D13AA Lineside T1 I/O connector pin	Lineside T1 cable connector to external equipment
33	Ground	5	DB9 female away from MMI (P4) Wired as DTE Data is transmitted on pin 2 (TXD) and received on pin 3 (RXD)
8	Control 1	7	
32	Control 2	9	
30	Away from MMI terminal Transmit Data	3	
6	Away from MMI terminal Receive Data	2	

**T1 connections**

T1 signaling for all 24 channels is transmitted over P2 connector pins 1, 3, 9, and 11 as shown in Table 86 on [page 217](#). Plug the DB15 male connector labeled “P2” into the T1 link. T1 transmit and receive pairs must be turned over between the lineside T1 card and CPE equipment that is hardwired without carrier facilities. If the lineside T1 card is connected through T1 carrier facilities, the transmit and receive pairs must be wired straight through to the RJ48 at the Telco demarc, the CSU, or other T1 carrier equipment. The T1 CPE equipment at the far end will also have transmit and receive wired straight from the RJ48 demarc at the far end of the carrier facility.

**External alarm connections**

P3 connector pins 3, 4, and 28 can be plugged into any external alarm hardware. Plug the male DB9 connector labeled “P3” into the external alarm. These connections are optional, and the functionality of the lineside T1 card is not affected if they are not made.

The MMI (described in detail in “Man-Machine T1 maintenance interface software” on [page 225](#)) monitors the T1 link for specified performance criteria and reports on problems detected.

One of the ways it can report information is through this external alarm connection. If connected, the lineside T1 card's microprocessor activates the external alarm hardware if it detects certain T1 link problems that it has classified as alarm levels 1 or 2. See "Man-Machine T1 maintenance interface software" on [page 225](#) for a detailed description of alarm levels and configuration. If an alarm level 1 or 2 is detected by MMI, the lineside T1 card will close the contact that is normally open, and will open the contact that is normally closed. The MMI command **Clear Alarm** will return the alarm contacts to their normal state.

### **MMI connections**

P5 connector pins 2, 3, 5, 7 and 9 are used to connect the lineside T1 card to the MMI terminal and daisy chain lineside T1 cards together for access to a shared MMI terminal. When logging into a lineside T1 card, "control 2" is asserted by that card, which informs all of the other cards not to talk on the bus, but rather to pass the data straight through. The pins labeled "control 1" are reserved for future use. As with the external alarm connections, MMI connections are optional. Up to 128 lineside T1 cards, located in up to 16 separate IPE shelves, can be linked to one MMI terminal using the daisy chaining approach.

If only *one* lineside T1 card is being installed, cable from the DB9 female connector labeled "P5" (towards MMI terminal) to one of the COM ports on the back of any TTY, a PC running a terminal emulation program, or a modem. For installations of only one card, no connection is made to the DB9 male connector labeled "P4" (away from MMI terminal).

If *two or more* lineside T1 cards are being installed into the system, the MMI port connections can be daisy-chained together so that only one MMI terminal is required for up to 128 lineside T1 cards. See Figure 33 on [page 221](#). Cards can be located in up to 16 separate IPE shelves. Any card slot in the IPE shelf can be connected to any other card slot; the card slots connected together do not need to be consecutive.

**Procedure 12**

**Connecting two or more lineside T1 cards to the MMI terminal**

Follow this procedure for connecting two or more lineside T1 cards to the MMI terminal:

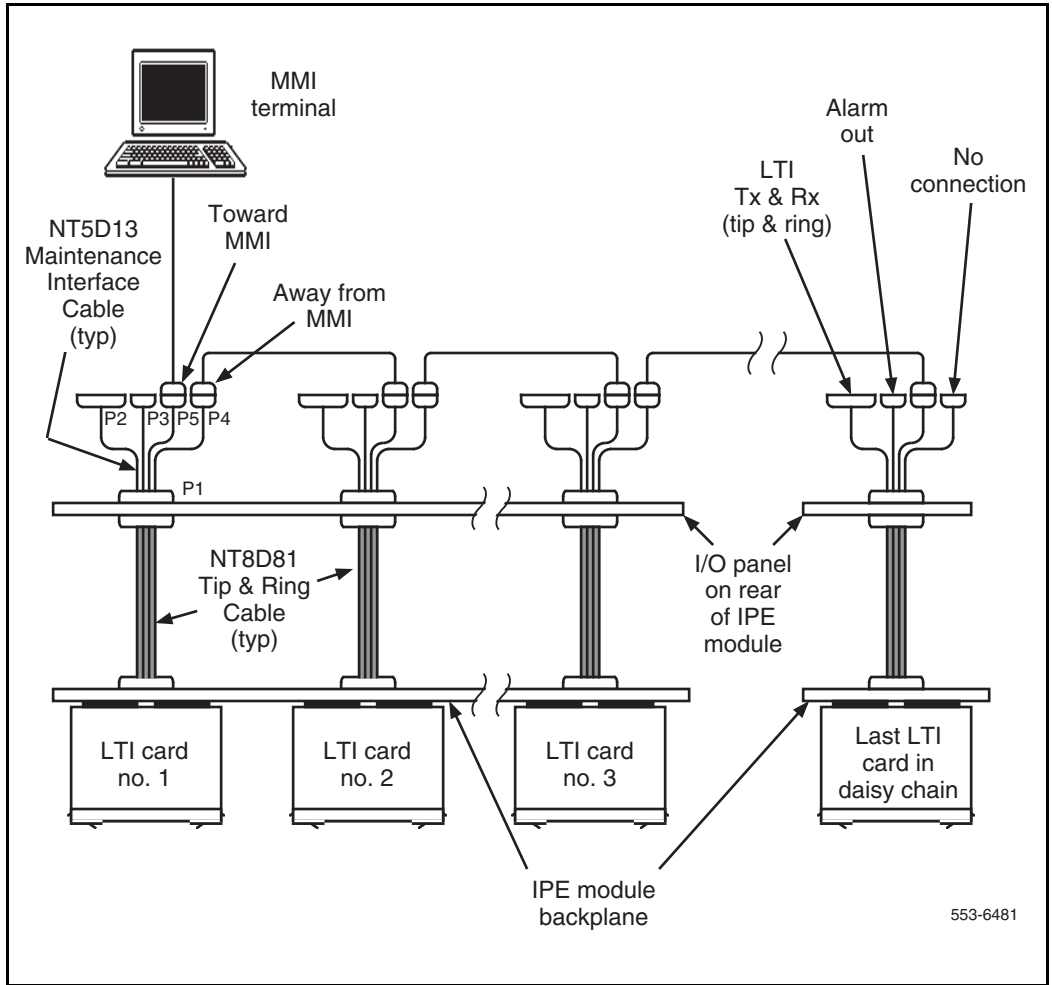
- 1 Cable the DB9 male connector labeled "P5" (towards MMI terminal) to one of the COM ports on the back of any TTY, a PC running a terminal emulation program, or a modem.
- 2 Make the connection from the first card to the second card by plugging the DB9 female connector labeled "P4" (away from MMI terminal) from the *first* card into the DB9 male connector of the second card labeled "P5" (towards MMI terminal).
- 3 Repeat Step 2 for the remaining cards.
- 4 When the last card in the daisy chain is reached, make no connection to the DB9 male connector labeled "P4" (away from MMI terminal).
- 5 If two lineside T1 cards are located too far apart to connect the "P4" and "P5" connectors together, connect them together with an off-the-shelf DB-9 female to DB-9 male straight-through extension cable, available at any PC supply store.

---

**End of Procedure**

---

**Figure 33**  
**Lineside T1 card – connecting two or more cards to the MMI**



## Terminal configuration

For the MMI terminal to be able to communicate to the lineside T1 card, the interface characteristics must be configured to the following:

- Speed – 1200 or 2400 bps, depending on the setting of switch position 1 of Switch 1
- Character width – 8 bits
- Parity bit – none
- Stop bits – one
- Software handshake (XON/XOFF) – off

## Software configuration

Although much of the architecture and many of the features of the lineside T1 card differ from the analog line card, the lineside T1 card has been designed to emulate an analog line card to the CS 1000 Release 4.5 software. Because of this, the lineside T1 card software configuration is performed the same as two adjacent analog line cards.

All 24 T1 channels carried by the lineside T1 card are individually configured using the Analog (500/2500-type) Telephone Administration program LD 10. Use Table 87 on [page 223](#) to determine the correct unit number and the NTP *Software Input/Output: Administration* (553-3001-311) for LD 10 service change instructions.

The lineside T1 card circuitry routes 16 units (0-15) on the motherboard and eight (0-7) units on the daughterboard to 24 T1 channels. The motherboard circuit card is located in the left card slot, and the daughterboard circuit card is located in right card slot. For example, if the lineside T1 card is installed into card slots 0 and 1, the motherboard would reside in card slot 0 and the daughterboard would reside in card slot 1. In order to configure the terminal equipment through the switch software, the T1 channel number must be

cross-referenced to the corresponding card unit number. This mapping is shown in Table 87.

**Table 87**  
**DX-30 to T1 time slot mapping (Part 1 of 2)**

Item	TN	T1 Channel Number
Motherboard	0	1
Motherboard	1	2
Motherboard	2	3
Motherboard	3	4
Motherboard	4	5
Motherboard	5	6
Motherboard	6	7
Motherboard	7	8
Motherboard	8	9
Motherboard	9	10
Motherboard	10	11
Motherboard	11	12
Motherboard	12	13
Motherboard	13	14
Motherboard	14	15
Motherboard	15	16
Daughterboard	0	17
Daughterboard	1	18
Daughterboard	2	19
Daughterboard	3	20

**Table 87**  
**DX-30 to T1 time slot mapping (Part 2 of 2)**

Item	TN	T1 Channel Number
Daughterboard	4	21
Daughterboard	5	22
Daughterboard	6	23
Daughterboard	7	24

**Disconnect supervision**

The lineside T1 card supports far-end disconnect supervision by opening the tip side toward the terminal equipment upon the system's detecting a disconnect signal from the far-end on an established call. The Supervised Analog Line feature (SAL) must be configured in LD 10 for each lineside T1 port. At the prompt FTR, respond:

**OSP <CR>**

and against FTR respond:

**ISP <CR>**

The lineside T1 card treats OSP and ISP for both originating and terminating calls as hook flash disconnect supervision, also known as cut-off disconnect. Originating calls are outgoing from the terminal equipment. Terminating calls are incoming to the terminal equipment. The lineside T1 card does not support battery reversal answer and disconnect supervision on originating calls.

After the software is configured, power up the card and verify the self test results. The **STATUS LED** on the faceplate indicates whether or not the lineside T1 card has passed its self test, and is functional. When the card is installed, this LED remains lit for two to five seconds as the self-test runs. If the self-test completes successfully, the LED flashes three times and remains lit. When the card is configured and enabled in software, the LED goes out. The LED goes out if either the motherboard or daughterboard is enabled by the software. If the LED flashes continuously or remains weakly lit, replace the card.



# Man-Machine T1 maintenance interface software

## Description

The Man-Machine Interface (MMI) supplies a maintenance interface to a terminal that provides T1 link diagnostics and historical information. See “Installation and configuration” on [page 204](#) for instructions on how to install the cabling and configure the terminal for the MMI.

This section describes the features of MMI and explains how to configure and use the MMI firmware.

The MMI provides the following maintenance features:

- default and reconfigurable alarm parameters
- notification of T1 link problems by activating alarms
- Reports on current and historical T1 link performance
- T1 tests for T1 verification and fault isolation to lineside T1 card, T1 link, or CPE equipment

## Alarms

MMI activates alarms for the following T1 link conditions:

- excessive bit error rate
- frame slip errors
- out of frame condition
- loss of signal condition
- blue alarm condition

The alarms are activated in response to pre-set thresholds and error durations. Descriptions of each of these T1 link alarm conditions, instructions on how to configure alarm parameters, and access alarm reporting can be found in “Alarm operation and reporting” on [page 236](#).

Two levels of alarm severity exist for bit errors and frame slip errors. For these conditions, two different threshold and duration configurations are established.

When the first level of severity is reached (alarm level 1), the MMI will do the following:

- activate the external alarm hardware
- light the appropriate LED on the faceplate (either RED ALARM or YELLOW ALARM)
- display an alarm message on the MMI terminal
- create entry in the alarm log

When the second level of severity is reached (alarm level 2), the MMI will perform all of the same functions as alarm level 1, and in addition, force the lineside T1 card to enter trunk processing mode. In this mode, the terminal equipment will be sent either “on-hook” or “off-hook” signals for all 24 ports to the CS 1000S, CS 1000M, and Meridian 1, depending on how the dip switch for trunk processing was set (dip switch #2, position #6).

If the MMI detects T1 link failures for any of the remainder of the conditions monitored (out of frame condition, loss of signal condition, and blue alarm condition), the lineside T1 card automatically performs all alarm level 2 functions. The MMI also sends a yellow alarm to the distant end CPE or CSU.

Alarms can be configured to self-clear or not self-clear when the alarm condition is no longer detected.

All alarms activated produce a record in an alarm log. The alarm log maintains records for the most recent 100 alarms and can be displayed, printed and cleared. The alarm log displays or prints the alarms listing the most recent first in descending chronological order. The alarms are stamped with the date and time they occurred.

### **T1 performance counters and reports**

The MMI maintains performance error counters for the following T1 conditions:

- errored seconds

- bursty seconds
- unavailable seconds
- framer slip seconds
- loss of frame seconds

It retains the T1 performance statistics for the current hour, and for each hour for the previous 24 hours. Descriptions of each of these performance error counters, and instructions on how to report on them and clear them can be found in “Performance counters and reporting” on [page 239](#).

### **T1 verification and fault isolation testing**

The MMI performs various tests to verify that the T1 is working adequately, or help to isolate a problem to the lineside T1 card, the T1 link, or the CPE equipment. Descriptions of all of these tests and instructions on how to run them can be found in “Testing” on [page 241](#).

## **Login and password**

The MMI can be accessed through a TTY, a PC running a terminal emulation program, or a modem. After installing the MMI terminal and card cables, the MMI firmware can be accessed.

For single card installations, log in by entering:

**L<CR>**

For multiple card installations connected in a daisy-chain, log in by entering:

**L <address>**

where the four-digit address is the two-digit address of the IPE shelf as set by dip switch positions (dip switch #1, positions 3-6) on the card (as opposed to the address set in the CS 1000 Release 4.5 software), plus the two-digit address of the card slot that the motherboard occupies. For example, to login to a card located in shelf 13, card slot 4, type:

**L 13 4 <CR>**

A space is inserted between the login command (L), the shelf address, and the card slot address.

The MMI then prompts for a password. The password is “**LTILINK**”, and it must be typed all in capital letters.

After logging in, the prompt will then look like this:

- **LTI:::>** for single-card installations
- **LTI:ss cc>** for multi-card installations, where ss represents the two-digit address, and cc represents the two-digit card slot address

## Basic commands

MMI commands can now be executed. There are seven basic commands that can be combined together to form a total of 19 command sets. They are:

- Alarm
- Clear
- Display
- Set
- Test
- Help
- Quit

If ?<CR> is typed, the MMI will list the above commands along with an explanation of their usage. A screen similar to the following will appear. The help screen can also appear by typing H<CR>, or HELP<CR>.

```
ALARM   USAGE: Alarm [Enable | Disable]
CLEAR   USAGE: Clear [Alarm] | [Error counter] [Log]
DISPLAY USAGE: Display [Alarm | Status | Perform |
             History] [Pause]
HELP    USAGE: Help | ?
SET     USAGE: Set [Time | Date | Alarm | Clearing |
             Name | Memory]
TEST    USAGE: Test [Carrier All]
QUIT    USAGE: Quit
```

Notation Used:

CAPS - Required Letters [ ] - Optional | - Either/Or

Each of these commands can be executed by typing the first letter of the command or by typing the entire command. Command sets are entered by typing the first letter of the first command, a space, and the first letter of the second command or by typing the entire command. Table 88 shows all the possible command sets, listed in alphabetical order. These commands are described by subject later in this section.

**Table 88**  
**MMI commands and command sets (Part 1 of 3)**

Command	Description
A D	<b>Alarm Disable</b> Disables all alarms.
A E	<b>Alarm Enable</b> Enables all alarms.
C A	<b>Clear Alarm</b> Clears all alarms, terminates line processing, and resets the T1 bit error rate and frame slip counters.
C A L	<b>Clear Alarm Log</b> Clears the alarm log.

**Table 88**  
**MMI commands and command sets (Part 2 of 3)**

Command	Description
C E	<p><b>Clear Error</b>                      Clears the error counter for the T1.</p>
D A [P]	<p><b>Display Alarms [Pause]</b>                      Displays the alarm log – a list of the most recent 100 alarms along with time and date stamps.</p>
D C	<p><b>Display Configuration</b>                      Displays the configuration settings for the cards including:</p> <ul style="list-style-type: none"> <li>• the serial number of the card</li> <li>• MMI firmware version</li> <li>• date and time</li> <li>• alarm enable/disable setting</li> <li>• self-clearing enable/disable setting</li> <li>• settings entered in Set Configuration</li> <li>• dip switch settings</li> </ul>
D H [P]	<p><b>Display History [Pause]</b>                      Displays performance counters for the past 24 hours.</p>
D P	<p><b>Display Performance</b>                      Displays performance counters for the current hour.</p>
D S [P]	<p><b>Display Status [Pause]</b>                      Displays carrier status, including whether the card is in the alarm state, and what alarm level is currently active.</p>
H or ?	<p>Help                      Displays the help screen.</p>
L	<p>Login                      Logs into the MMI terminal when the system has one lineside T1 card.</p>

**Table 88**  
**MMI commands and command sets (Part 3 of 3)**

<b>Command</b>	<b>Description</b>
Q	<b>Quit</b> Logs the terminal user out. If multiple lineside T1 cards share a single terminal, logout after using the MMI. Because of the shared daisy-chained link, if a lineside T1 card is logged in, it occupies the bus and no other lineside T1 cards are able to notify the MMI of alarms.
S A	<b>Set Alarm parameters</b> Alarm parameters include the allowable bit errors per second threshold and alarm duration.
S C	<b>Set Clearing</b> Sets the alarm self-clearing function to either <i>enable</i> or <i>disable</i> .
S D	<b>Set Date</b> Sets date or verifies current date.
S T	<b>Set time</b> Sets time or verifies current time.
T x	<b>Test</b> Initiates the T1 carrier test function. To terminate a test in process, enter the STOP TEST (S) command at any time.

## Configuring parameters

The MMI has been designed with default settings so that no configuration is necessary. However, it can be configured to suit a specific environment.

### Set Time

Before configuring the MMI, login to the system and enter the current time. Do this by typing in the Set Time (S T) command set. The MMI will then display the time it has registered. Enter a new time or press “Enter” to leave it unchanged. The time is entered in the “hh:mm:ss” military time format.

### Set Date

The current date must be set. Do this by typing in the Set Date (S D) command set. MMI will then display the date it has registered. Enter a new date or press “Enter” to leave it unchanged. The date is entered in the “mm/dd/yy” format.

### Alarm parameters

The Set Alarm (S A) command set establishes the parameters by which an alarm is activated, and its duration. There are three alarm activation levels:

- **Alarm Level 0 (AL0)** consists of activity with an error threshold below the AL1 setting. This is a satisfactory condition and no alarm is activated.
- **Alarm Level 1 (AL1)** consists of activity with an error threshold above the AL1 setting but below AL2 setting. This is a minor unsatisfactory condition. In this situation, the external alarm hardware will be activated by closing the normally open contact, the RED ALARM LED on the faceplate will light, and an alarm message will be created in the alarm log and the MMI terminal.
- **Alarm Level 2 (AL2)** consists of activity with an error threshold above the AL2 setting. This is an unsatisfactory condition. In this situation, the external alarm hardware will be activated by closing the normally open contact, the RED ALARM LED on the faceplate will light, an alarm message will be created in the alarm log and the MMI terminal, the lineside T1 card will enter line processing mode, and a yellow alarm message will be sent to the CPE/CSU. Line processing will send the CS 1000S, CS 1000M, and Meridian 1 either all “on-hook” or all “off-hook” signals, depending on the dip switch setting of the card.



When the Set Alarm command is used, a prompt appears to configure the threshold level and duration period for alarm levels 1 and 2.

The threshold value indicates the number of bit errors detected per second that is necessary to activate the alarm. The T1 link processes at a rate of approximately 1.5 mb/s. The threshold value can be set between 3 and 9 and can be different for each alarm level. Any other value entered will cause the software to display a “Parameter Invalid” message. The threshold number entered represents the respective power of 10 as shown in Table 89.

*Note:* The error rate threshold for a level 2 alarm must be greater (a smaller power of 10) than for a level 1 alarm.

**Table 89**  
**T1 bit error rate threshold settings**

Alarm threshold bit errors per second in power of 10	Threshold to set alarm	Allowable duration periods
$10^{-3}$	1,500/second	1–21 seconds
$10^{-4}$	150/second	1–218 seconds
$10^{-5}$	15/second	1–2148 seconds
$10^{-6}$	1.5/second	1–3600 seconds
$10^{-7}$	1.5/10 seconds	10–3600 seconds
$10^{-8}$	1.5/100 seconds	100–3600 seconds
$10^{-9}$	1.5/1000 seconds	1000–3600 seconds

The duration value is set in seconds and can be set from 1 to 3600 seconds (1 hour). This duration value indicates how long the alarm will last. Low bit error rates ( $10^{-7}$  through  $10^{-9}$ ) are restricted to longer durations since it takes more than one second to detect an alarm condition above  $10^{-6}$ . Higher bit error rates are restricted to shorter durations because the MMI error counter fills at 65,000 errors.

The alarm indications (LEDs and external alarm contacts) clear automatically after the duration period has expired, if the Set Clearing (S C) “Enable Self

Clearing” option has been set. Otherwise, the alarm will continue until the command set Clear Alarm (C A) has been entered.

When an alarm is cleared, the following activity caused by the alarm will be cleared:

- the external alarm hardware will be deactivated (the contact normally open will be reopened)
- the LED light will go out
- an entry will be made in the alarm log of the date and time the alarm was cleared
- carrier fail line supervision will cease (for alarm level 2 only)

If self-clearing alarm indications have been disabled, carrier fail line supervision will terminate when the alarm condition has ceased, but the alarm contact and faceplate LED will remain active until the alarm is cleared.

**Note:** A heavy bit error rate can cause 150 bit errors to occur in less than 100 seconds. This will cause the alarm to be activated sooner.

An alarm will not be automatically cleared until the system no longer detects the respective bit error threshold during the corresponding duration period. For example, if an AL1 threshold of 6 (representing  $10^{-6}$ ) and a duration period of 100 seconds is specified, an alarm will be activated if more than 150 bit errors occur in any 100 second period ( $1.5 \text{ seconds} \times 100 \text{ seconds} = 150 / 100 \text{ seconds}$ ). As soon as the alarm is activated, the bit counter is reset to 0. If the next 100 seconds pass, and less than 150 bit errors are detected, then the alarm will clear after the duration period. However, if more than 150 bit errors are detected in the next 100 seconds, the alarm continues for the designated duration period. The alarm will finally clear when the alarm condition is no longer detected for the designated duration period either by self-clearing (if this function is enabled), or when the Clear Alarm (C A) command set is entered.

In addition to bit errors, the Set Alarm function configures parameters for detecting frame slip errors, by establishing a threshold necessary to activate an alarm. If the threshold value is exceeded, a level 2 alarm will be activated. The frame slip threshold can be specified from 1 to 255 frame slips per time period. The duration time period can be specified from 1 to 24 hours.

When entering the Set Alarm command set, the MMI will scroll through the previously described series of alarm options. These options are displayed along with their current value. Enter a new value or press Enter to retain the current value. Table 90 outlines the options available in the Set Alarm function.

**Table 90**  
**Set alarm options**

Option	Description
AL1 Threshold	Sets the allowable bit errors per second (from 3 to 9) before alarm level 1 is activated. Factory default is $10^{-6}$ .
AL1 Duration	Sets the duration in seconds (from 1 to 3,600 seconds) that alarm level 1 is activated. Factory default is 10 seconds.
AL2 Threshold	Sets the allowable bit errors per second (from 3 to 9) before alarm level 2 is activated. Factory default is $10^{-5}$ .
AL2 Duration	Sets the duration in seconds (from 1 to 3,600 seconds) that alarm level 2 is activated. Factory default is 10 seconds.
Frame Slip Threshold	Sets the allowable frame slips per time period (from 1 to 255) before alarm level 2 is activated. Factory default is 5.
Frame Slip Duration	Sets the duration in hours (from 1 to 24) that the frame slips are counted. After this time period, the counter is reset to 0. Factory default is 2 hours.

**Note:** If the duration period is set too long, the lineside T1 card will be slow to return to service automatically even when the carrier is no longer experiencing any errors. The Clear Alarm command will have to be entered manually to restore service promptly. To avoid this, the duration period should normally be set to 10 seconds.

### Set Clearing

Use the Set Clearing (S C) command set to enable or disable alarm self-clearing. Answer **Y** or **N** to the question: “Enable Self Clearing? (YES or NO)”. If “Enable Self-Clearing” is chosen (the factory default condition), the system will automatically clear alarms after the alarm condition is no longer detected for the corresponding duration period.

The “Disable Self-Clearing” option causes the system to continue the alarm condition until the Clear Alarm (C A) command set is entered. Line processing and the yellow alarm indication to the CPE is terminated as soon as the alarm condition clears, even if “Disable Self-Clearing” is set.

### Display Configuration

The Display Configuration (D C) command set displays the various configuration settings established for the lineside T1 card. Entering the Display Configuration (D C) command set causes a screen similar to the following to appear:

```
LTI S/N 1103 Software Version 1.01      3/03/95 1:50

Alarms Enabled: YES          Self Clearing Enabled: YES

Alarm Level 1 threshold value: E-7      Threshold duration
(in seconds): 10

Alarm Level 2 threshold value: E-5      Threshold duration
(in seconds): 1

Frame slips alarm level threshold: 5     Threshold duration
(in hours): 2

Current dip switch S1 settings (S1..S8) On Off Off On Off
Off Off On

Current dip switch S2 settings (S1..S8) On Off On Off Off
Off On Off
```

### Alarm operation and reporting

The MMI monitors the T1 link according to the parameters established through the Set Alarm command set for the following conditions:

- Excessive bit error rate
- Frame slip errors
- Out of frame condition
- Loss of signal condition
- Blue alarm (AIS) condition

Descriptions of the excessive bit error rate and frame slip errors conditions can be found in “Configuring parameters” on [page 232](#). Bit errors may activate either a level 1 or level 2 alarm. The remaining conditions, when detected, will always cause the system to activate a level 2 alarm.

An out of frame condition will be declared if two out of four frame bits are in error. If this condition occurs, the hardware will immediately attempt to reframe. During the reframe time, the T1 link will be declared out of frame, and silence will be sent on all receive timeslots.

A loss of signal condition is declared if a full frame (192 bits) of consecutive zeros has been detected at the receive inputs. If this condition occurs, the T1 link will automatically attempt to resynchronize with the distant end. If this condition lasts for more than two seconds, a level 2 alarm will be declared, and silence will be sent on all receive timeslots. The alarm will be cleared if, after two seconds, neither a loss of signal, out of frame condition, nor blue alarm condition occurs.

If a repeating device loses signal, it immediately begins sending an unframed all 1’s signal to the far-end to indicate an alarm condition. This condition is called a blue alarm, or an Alarm Indication Signal (AIS). If an AIS is detected for more than two seconds, a level 2 alarm will be declared, and silence will be sent on all receive timeslots. The alarm will be cleared if, after two seconds, neither a loss of signal, out of frame condition, nor blue alarm condition occurs.

### **Alarm Disable**

The Alarm Disable (A D) command disables the external alarm contacts. When this command is typed, the MMI will display the message “Alarms Disabled” and the MAINT LED will light. In this mode, no yellow alarms are sent and the lineside T1 card will not enter line processing mode. Alarm messages will still be sent to the MMI terminal and the LED light will continue to indicate alarm conditions.

### **Alarm Enable**

The Alarm Enable (A E) command set does the opposite of the Alarm Disable command set. It enables the external alarm contacts. When this command set is typed in, the MMI will display the message “Alarms Enabled.” In this

mode, yellow alarms can be sent and the lineside T1 card can enter line processing mode.

### **Clear Alarm**

The Clear Alarm (C A) command set will clear all activity initiated by an alarm: the external alarm hardware will be deactivated (the contact normally open will be reopened), the LED light will go out, an entry will be made in the alarm log of the date and time the alarm was cleared, and line processing will cease (for alarm level 2 only). When this command set is typed in, the MMI will display the message “Alarm acknowledged.” If the alarm condition still exists, the alarm will be declared again.

### **Display Alarms**

A detailed report of the most recent 100 alarms with time and date stamps can be displayed by entering the Display Alarms (D A) command set into the MMI. Entering the Display Alarms (D A) command set will cause a screen similar to the following to appear:

```
Alarm Log
3/03/95 1:48 Yellow alarm on T1 carrier
3/03/95 1:50 Initialized Memory
3/03/95 2:33 T1 carrier level 1 alarm
3/03/95 3:47 T1 carrier level 2 alarm
3/03/95 4:43 T1 carrier performance within
thresholds
3/03/95 15:01 Log Cleared
```

The Pause command can be used to display a full screen at a time by entering D A P.

### **Clear Alarm Log**

Clear all entries in the alarm log by typing in the Clear Alarm Log (C A L) command set.

### **Display Status**

The Display Status (D S) command set displays the current alarm condition of the T1 link as well as the on-hook or off-hook status of each of the 24 ports

of the lineside T1 card. Entering the Display Status (D S) command set will cause a screen similar to the following to appear:

```
LTI S/N      Software Version 1.01      3/03/95 1:50
In alarm state: NO
T1 link at alarm level 0
Port 0 off hook, Port 1 on hook, Port 2 on hook,
Port 3 on hook,
Port 4 on hook, Port 5 on hook, Port 6 off hook,
Port 7 off hook,
Port 8 off hook, Port 9 on hook, Port 10 on hook,
Port 11 on hook,
Port 12 off hook, Port 13 on hook, Port 14 on hook,
Port 15 on hook,
Port 16 on hook, Port 17 on hook, Port 18 off hook,
Port 19 off hook,
Port 20 off hook, Port 21 on hook, Port 22 on hook,
Port 23 on hook
```

## Performance counters and reporting

The MMI monitors the performance of the T1 link according to several performance criteria including errored, bursty, unavailable, loss of frame and frame slip seconds. It registers the performance of these criteria by reading their status every second and counting their results. These counts are accumulated for an hour, and then they are reset to 0. Previous hour count results are maintained for each hour for the previous 24 hours.

Performance counts are maintained for the following:

- Errored seconds – one or more CRC-6 errors, or one or more out of frame errors in a second.
- Bursty seconds – more than one and less than 320 CRC-6 errors in a second.
- Unavailable seconds – unavailable state starts with 10 consecutive severely errored seconds and ends with 10 consecutive severely errored seconds (excluding the final 10 non-severely errored seconds). Severely errored seconds are defined as more than 320 CRC-6 errors, or one or more out of frames in a second.

- Loss of frame seconds – loss of frame or loss of signal for three consecutive seconds.
- Framers slip seconds – one ore more frame slips in a second.

The MMI also maintains an overall error counter that is a sum of all the errors counted for the five performance criteria listed above. The error counter can only be cleared by entering the “Clear Error” command. It will stop counting at 65,000. The error counter provides an easy method to determine if an alarm condition has been corrected. Simply clear the error counter, wait a few minutes, and display performance to see if any errors have occurred since the counter was cleared.

Display the reports on these performance counters by entering the Display Performance (D P) or the Display History (D H) command sets into the MMI.

### Display Performance

Enter the Display Performance (D P) command set to display performance counters for the past hour. A screen similar to the following will appear:

```
          LTI T1 Interface Performance Log
                3/03/95 1:37
Data for the past 37 Minutes
Errorred   Bursty   Unavaila   Loss      Frame      Error
Seconds   Seconds  ble       Frame     Slip       Counter
2263      0          2263     2263     352       321
```

Each column, except the error counter, indicates the number of errors in the current hour and is reset to zero every hour on the hour. When these counters are reset to zero, the performance counter values are put into the history log. The error counter indicates the number of errors that occurred since the error counter was cleared.



## Display History

Enter the Display History (D H) command set to display performance counters for each hour for the past 24 hours. A screen similar to the following will appear:

```

LTI T1 Interface History Performance Log
3/03/95 1:35
Hour   Error   Bursty   Unavaila   Loss   Frame   Error
      d     Second  ble        Frame  Slip    Counte
Endin  Second  Second   Seconds   Seconds Seconds  r
g      s      s
20:00  139     0        129       139    23      162
19:00  0        0         0          0       0        0
18:00  0        0         0          0       0        0
17:00  0        0         0          0       0        0
16:00  0        0         0          0       0        0

```

Use the pause command to display a full screen at a time by entering D H P.

## Clear Error

Reset the error counter to zero by entering the Clear Error (C E) command set. The error counter provides a convenient way to determine if the T1 link is performing without errors since it can be cleared and examined at any time.

## Testing

The Test Carrier (T C) command set enables tests to be run on the lineside T1 card, the T1 link, or the CPE device. These three tests provide the capability to isolate faulty conditions in any one of these three sources. See Table 91 on [page 242](#) for additional information on these three test types.

After entering the T C command set, select which test to start. The prompt appears, similar to the following:

```

Test 1: Local Loopback Test
Test 2: External Loopback Test
Test 3: Network Loopback Test
(1,2,3 or S to cancel):

```

Tests can be performed once (for 1 through 98 minutes), or continuously (selected by entering 99 minutes) until a “Stop Test” command is entered. Tests continue for the duration specified even if a failure occurs, and terminate at the end of the time period or when a “Stop Test” command is issued. Only a “Stop Test” command will stop a test with a duration selection of 99. After entering the test number selection, a prompt similar to the following will appear:

```
Enter Duration of Test (1-98 Mins, 0 = Once, 99 =
Forever)
Verify DS-30A Links are disabled.
Hit Q to quit or any Key to Continue
```

Before a test is run, verify that DS-30A links are disabled since the tests will interfere with calls currently in process.

During a test, if an invalid word is received, a failure peg counter is incremented. The peg counter saturates at 65,000 counts. At the end of the test, the Test Results message will indicate how many failures, if any, occurred during the test.

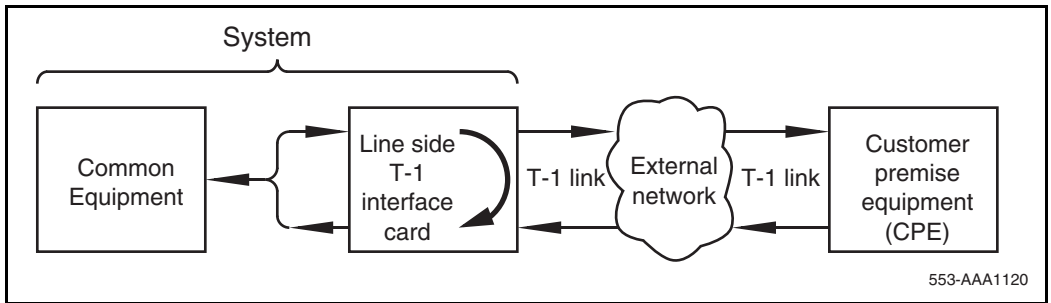
Table 91 shows which test to run for the associated equipment.

**Table 91**  
**MMI Tests**

Test number	Equipment tested	Test description
1	Lineside T1 card	Local loopback
2	T1 link, lineside T1 card and T1 network	External loopback
3	CPE device and T1 network	Network loopback

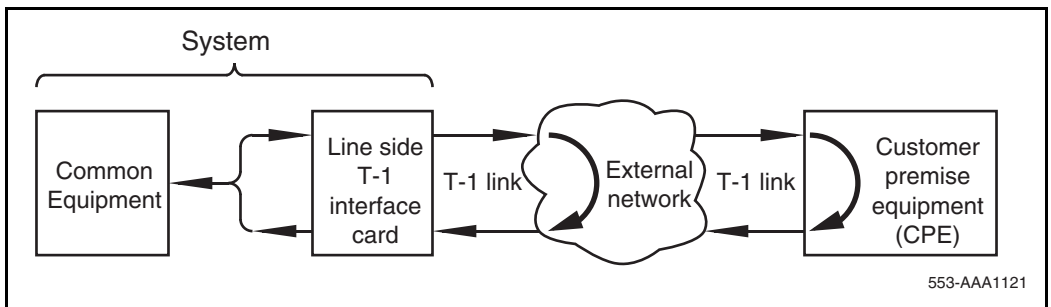
Test 1, local loopback, loops the T1 link signaling toward itself at the backplane connector, and test data is generated and received on all timeslots. If this test fails, it indicates that the lineside T1 card is defective. Figure 34 on [page 243](#) demonstrates how the signaling is looped back toward itself.

**Figure 34**  
**MMI local loopback test**



Test 2, external loopback, assumes an external loopback is applied to the T1 link. Test data is generated and received by the lineside T1 card on all timeslots. If test 1 passes but test 2 fails, it indicates that the T1 link is defective between the lineside T1 card and the external loopback location. If test 1 was not run and test 2 fails, the T1 link or the lineside T1 card could be defective. To isolate the failure to the T1 link, tests 1 and 2 must be run in tandem. Figure 35 demonstrates how an external loopback is applied to the T1 link.

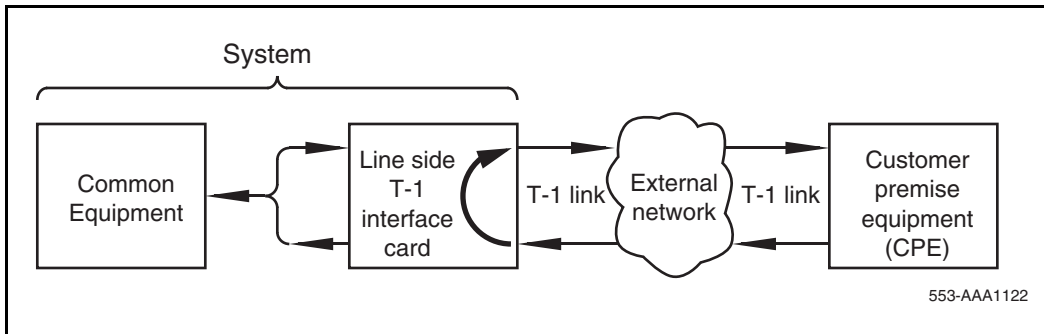
**Figure 35**  
**MMI external loopback test**



Test 3, network loopback, loops the received T1 data back toward the CPE equipment. No test data is generated or received by the lineside T1 card. If test 2 passes but test 3 fails, it indicates that the CPE device is defective. If test 2 was not run and test 3 fails, the T1 link or the CPE device could be defective. To isolate the failure to the CPE device, tests 2 and 3 must be run

in tandem. Figure 36 demonstrates how the signaling is looped back toward the CPE equipment.

**Figure 36**  
**MMI network loopback test**



## Applications

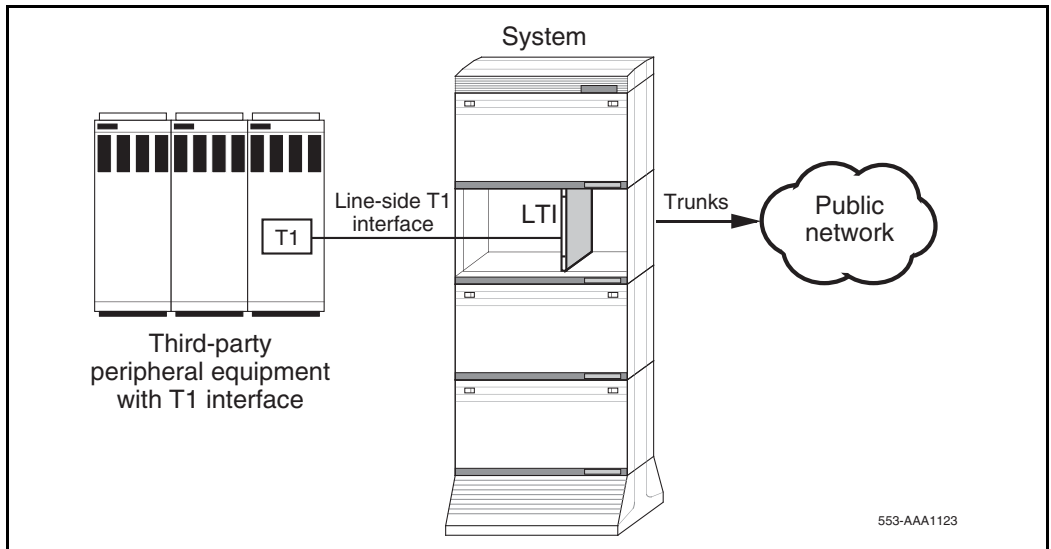
The lineside T1 interface is an IPE line card that provides cost-effective connection between T1-compatible IPE and a system or off-premise extensions over long distances.

Some examples of applications where a lineside T1 card can be interfaced to a T1 link are:

- T1 compatible Voice Response Unit (VRU) equipment
- T1 compatible turret systems
- T1 compatible wireless systems
- Remote analog (500/2500-type) telephones through T1 to a channel bank
- Remote Norstar sites behind CS 1000S, CS 1000M, and Meridian 1 over T1

The lineside T1 card is appropriate for any application where both T1 connectivity and “lineside” functionality is required. This includes connections to T1-compatible voice response units, voice messaging and trading turret (used in stock market applications) systems. See Figure 37.

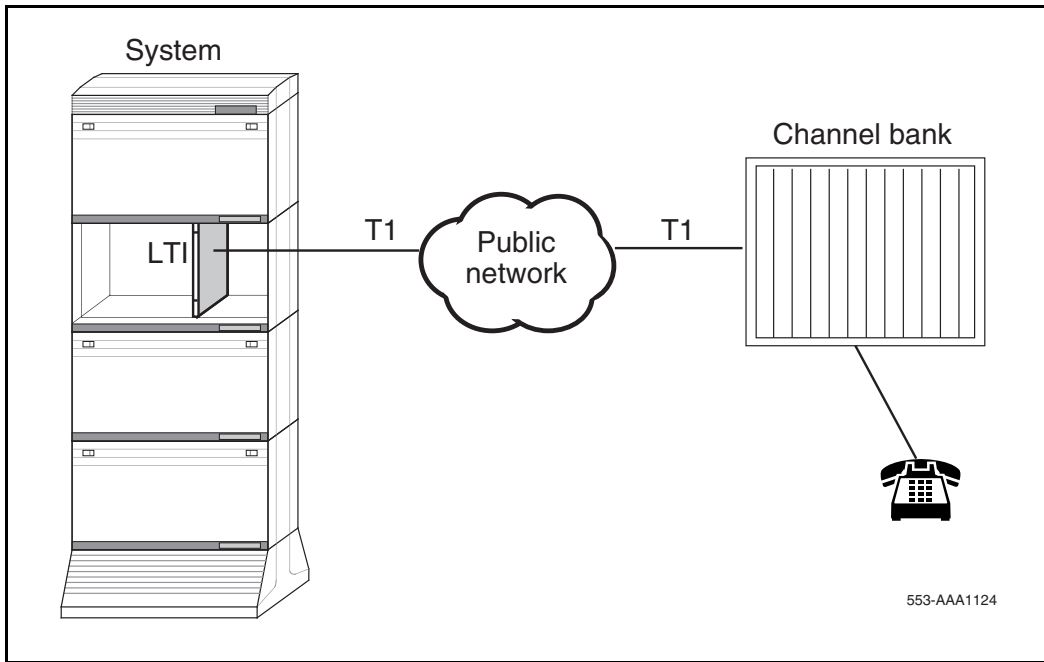
**Figure 37**  
**Lineside T1 interface connection to IPE**



For example, the lineside T1 card can be used to connect the system to a T1-compatible VRU. An example of this type of equipment is Nortel Open IVR system. In this way, the system can send a call to the VRU. Because the lineside T1 card supports analog (500/2500-type) telephones, the VRU is able to send the call back to the system for further handling.

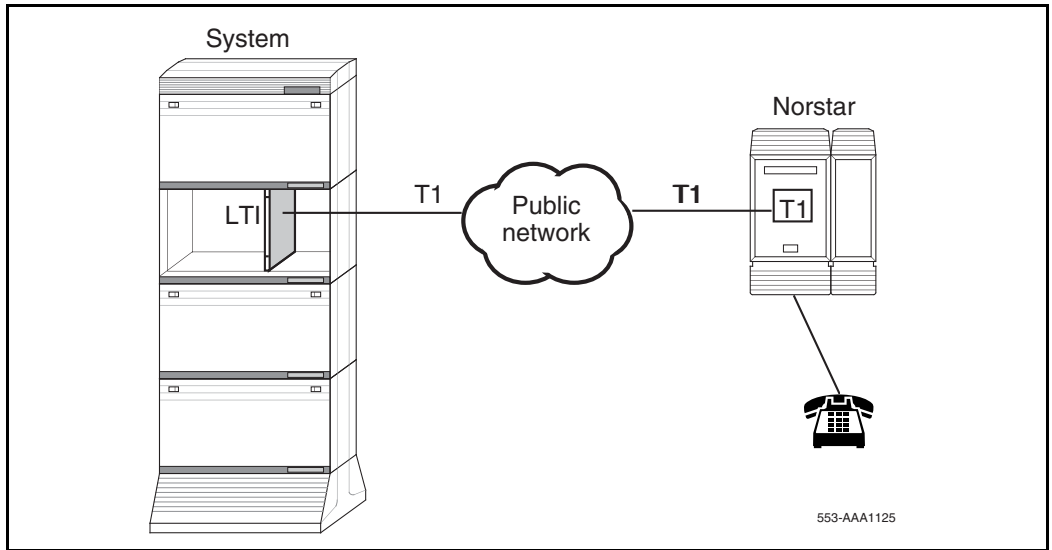
The lineside T1 card can also be used to provide off-premise extensions to remote locations (up to 500 miles from the system). In this application, the analog telephone functionality is extended over T1 facilities, providing a telephone at a remote site with access to analog (500/2500-type) telephone lines. See Figure 38 on [page 246](#). An audible message-waiting indicator can be provided as well.

**Figure 38**  
**Lineside T1 interface in off-premise application**



Similarly, the lineside T1 can be used to provide a connection between the system and a remote Norstar system. See Figure 39. In this case, channel banks would not be required if the Norstar system is equipped with a T1 interface.

**Figure 39**  
**Lineside T1 interface connection to Norstar system**



**Note:** The lineside T1 card audio levels must be considered when determining the appropriateness of an application.





---

# NT5D33 and NT5D34 Lineside E1 Interface cards

---

## Contents

This section contains information on the following topics:

Introduction . . . . .	249
Physical description . . . . .	250
Functional description . . . . .	255
Electrical specifications . . . . .	261
Installation and Configuration . . . . .	263
Installation . . . . .	271
Man-Machine E1 maintenance interface software . . . . .	284
Applications . . . . .	310

## Introduction

Two vintages of NT5D33 and NT5D34 cards are supported:

- NT5D33AB/NT5D34AB – standard Lineside E1 Interface (LEI) cards

The LEI card is an IPE line card that provides an all-digital connection between E1-compatible terminal equipment (such as a voice mail system) and CS 1000S, CS 1000M, or Meridian 1.

The LEI interfaces one E1 line, carrying 30 channels, to the CS 1000S, CS 1000M, or Meridian 1, and emulates an analog line card to the system software. Each channel is independently configured by software control

in the Analog (500/2500-type) Telephone Administration program LD 10. The LEI also comes equipped with a Man-Machine Interface (MMI) maintenance program, which provides diagnostic information regarding the status of the E1 link.

- NT5D33AC/NT5D34AC – Enhanced Lineside E1 Interface (ELEI) cards

The ELEI card is similar to an LEI card, but has been enhanced to allow the capability of transporting caller information using the proprietary signaling interface Channel Associated Signaling (CAS+).

ELEI cards can operate in one of two modes: LEI mode, or enhanced (ELEI) mode. In LEI mode, this card is fully compatible with, and provides the same functionality as, the standard LEI card. In ELEI mode, this card can be connected to any CAS+ compliant systems. This includes wireless server hosting Digital Enhanced Cordless Telephones (DECTs), voice response units, voice messaging systems, and trading turrent systems (used in stock market applications). More information regarding CAS+ can be obtained through Nortel Development Partner program.

*Note:* As the ELEI cards provide identical functionality to LEI cards, references to LEI cards in this chapter also apply to ELEI cards unless specified otherwise.

Install the NT5D33 version of the LEI/ELEI card in the NT8D37 IPE module.

Install the NT5D34 version of the LEI/ELEI card in:

- the NTAK11 Cabinet
- the NTAK12 Expansion Cabinet
- the NT1P70 Small Remote IPE Main Cabinet
- the NTAK12 Small Remote IPE Expansion Cabinet

## Physical description

The LEI mounts in two consecutive card slots in the IPE shelf. It uses 16 channels on the first slot and 14 channels on the second. The LEI includes a

motherboard (31.75 by 25.40 cm (12.5 by 10 in) and a daughterboard (5.08 by 15.24 cm (2 by 6 in).

## Card connections

The LEI uses the NT8D81AA Tip and Ring cable to connect from the IPE backplane to the 25-pair Amphenol connector on the IPE Input/Output (I/O) panel. The I/O panel connector connects to a E1 line, external alarm and an MMI terminal or modem, using the NT5D35 or NT5D36 lineside I/O cable available from Nortel.

## Faceplate

The LEI faceplate is twice as wide as the other standard analog and digital line cards. It occupies two card slots. The LEI faceplate has four LEDs. See Figure 40 on [page 252](#) (IPE version), and Figure 41 on [page 253](#) (Cabinet system).

Figure 40  
NT5D33AB LEI card – faceplate

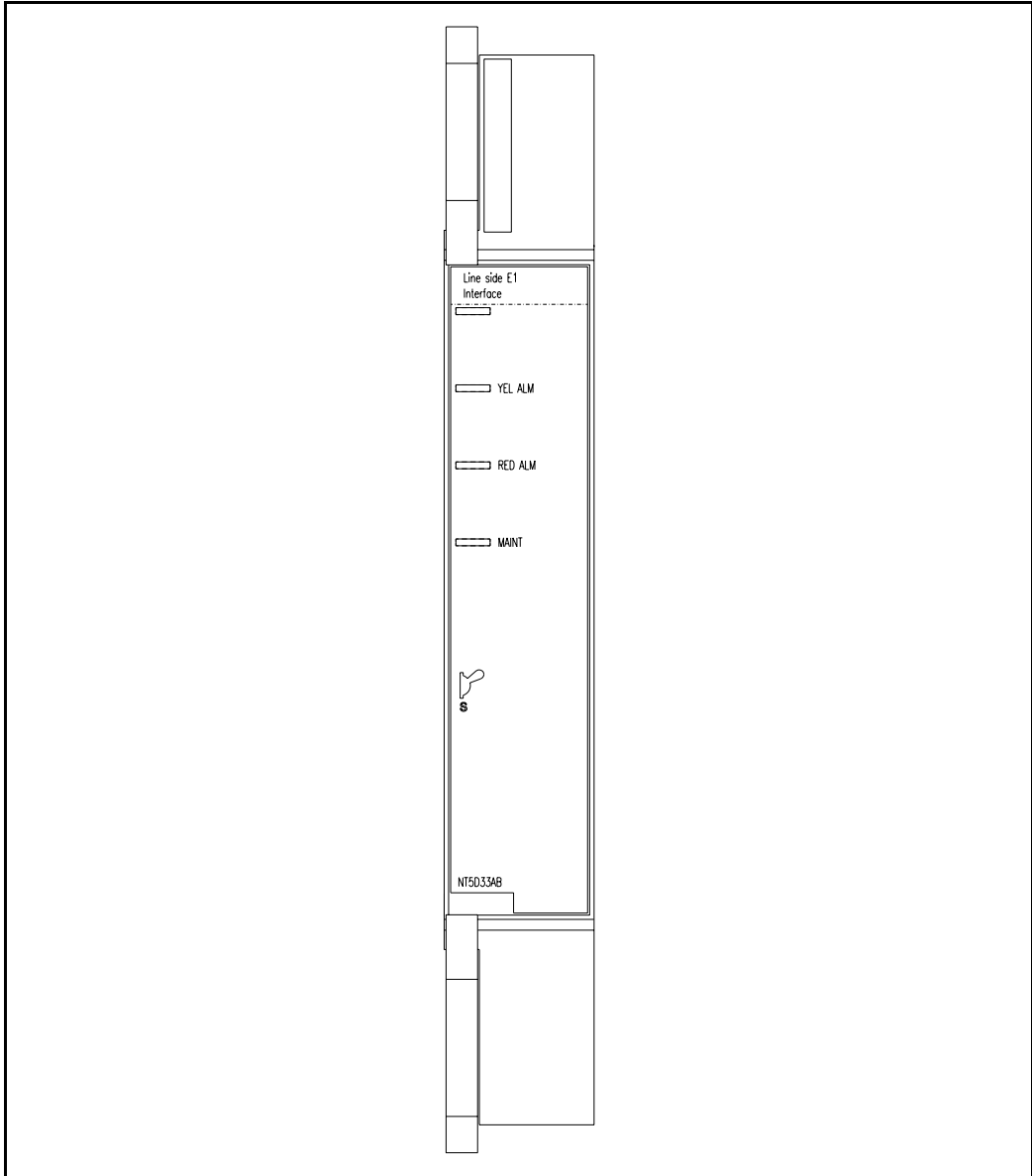
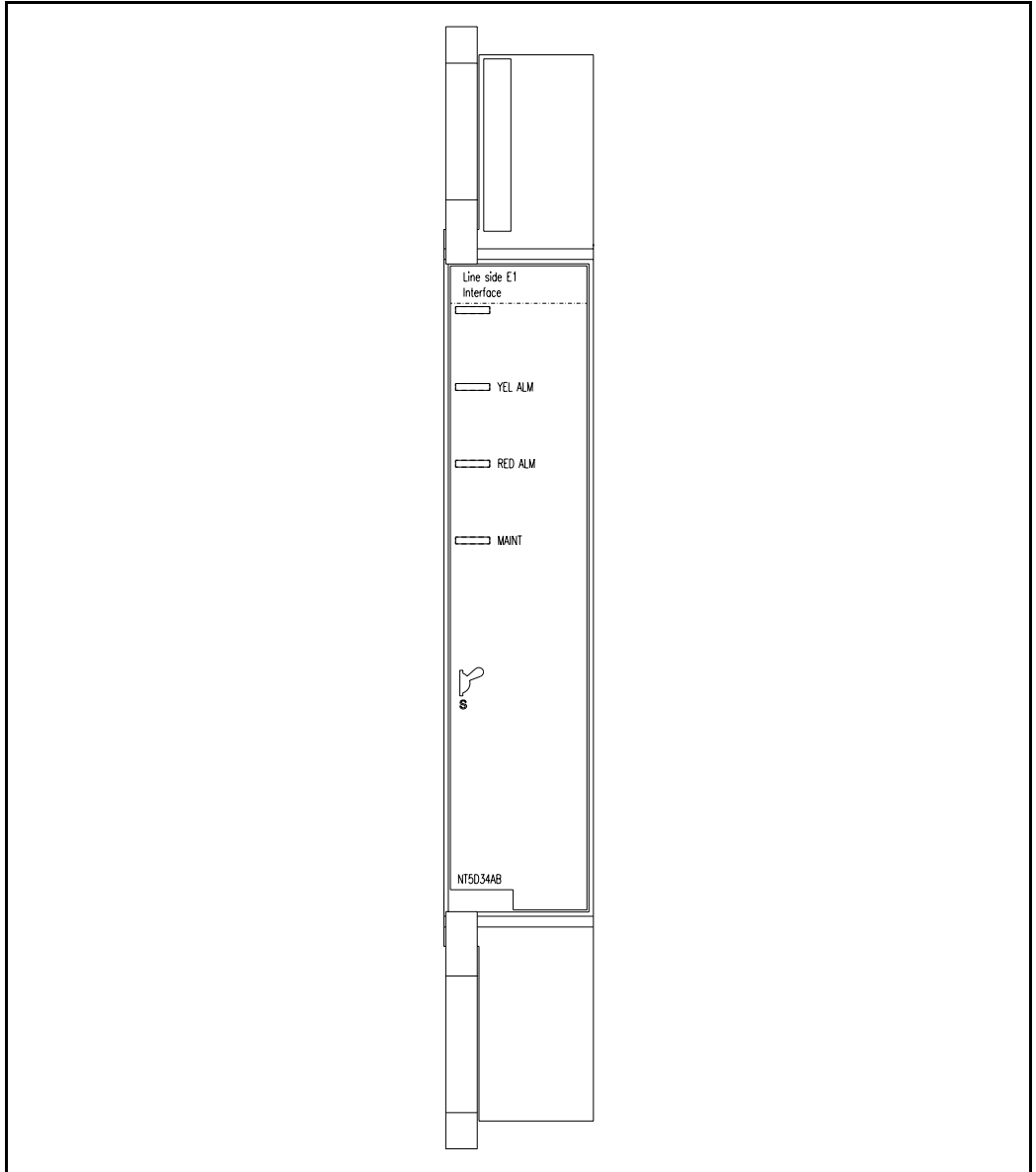


Figure 41  
NT5D34AB LEI card – faceplate



The LEDs give status indications on the operations as described in Table 92.

**Table 92**  
**LEI card LED operation**

LED	Operation
Status	Line card
Red alarm	E1 near end
Yellow alarm	E1 far end
Maint	Maintenance

The **STATUS** LED indicates if the LEI has successfully passed its self test, and therefore, if it is functional. When the card is installed, this LED remains lit for two to five seconds as the self-test runs. If the self-test completes successfully, the LED flashes three times and remains lit. When the card is configured and enabled in software, the LED goes out. If the LED continually flashes or remains weakly lit, replace the card.

The STATUS LED indicates the enabled/disabled status of both card slots of the LEI simultaneously. To properly enable the card, both the motherboard and the daughterboard slots must be enabled. The STATUS LED will turn off as soon as either one of the LEI slots have been enabled. No LED operation will be observed when the second card slot is enabled. To properly disable the card, both card slots must be disabled. The LED will not turn on until both card slots have been disabled.

The **RED ALARM LED** indicates if the LEI has detected an alarm condition from the E1 link. Alarm conditions can include such conditions as not receiving a signal, the signal has exceeded bit error thresholds or frame slip thresholds. See “Man-Machine E1 maintenance interface software” on [page 284](#) for information on E1 link maintenance.

If one of these alarm conditions is detected, this LED will light. Yellow alarm indication is sent to the far end as long as the near end remains in a red alarm

condition. Depending on how the Man Machine Interface (MMI) is configured, this LED will remain lit until one the following actions occur:

- If the “Self-Clearing” function is enabled in the MMI, the LED will clear the alarm when the alarm condition is no longer detected. This is the factory default configuration.
- If the “Self-Clearing” function has not been enabled or it has been subsequently disabled in the MMI, the LED alarm indication will stay lit until the command “Clear Alarm” has been typed in the MMI, even though the carrier automatically returned to service when the alarm condition was no longer detected.

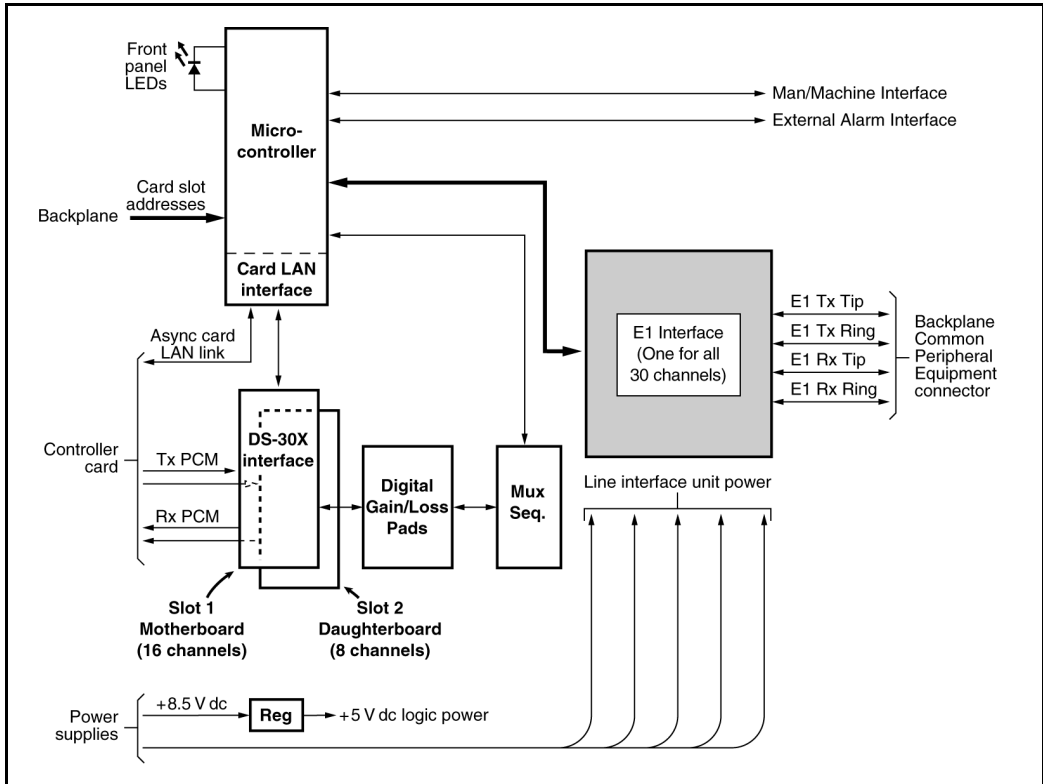
The **YELLOW ALARM** LED indicates that the LEI has detected a yellow alarm signal from the terminal equipment side of the E1 link. See “Man-Machine E1 maintenance interface software” on [page 284](#) for information on E1 link maintenance. If the terminal equipment detects a red alarm condition such as not receiving a signal, or the signal exceeds bit-error thresholds or frame-slip thresholds, a yellow alarm signal is sent to the LEI, if the terminal equipment supports this feature. If a yellow alarm signal is detected, this LED will light.

The **MAINT** LED indicates if LEI is fully operational because of certain maintenance commands that are issued through the MMI. See “Man-Machine E1 maintenance interface software” on [page 284](#) for information on E1 link maintenance. If the card detects that tests are being run or that alarms have been disabled through the MMI, this LED will light and will remain lit until these conditions are no longer detected, then it turns off.

## Functional description

Figure 42 on [page 256](#) shows a block diagram of the major functions contained on the LEI card. Each of these functions is described on the following pages.

**Figure 42**  
**LEI card – block diagram**





## Overview

The LEI card is an IPE line card that provides a cost-effective, all-digital connection between E1-compatible terminal equipment (such as voice mail systems, voice response units, trading turrets, etc.) and the system. In this application, the terminal equipment can be assured access to analog (500/2500-type) telephone line functionality such as hook flash, SPRE codes and ringback tones. The LEI supports line supervision features such as loop and ground start protocols. It can also be used in an off-premise arrangement where analog (500/2500-type) telephones are extended over twisted-pair or coaxial E1 with the use of channel bank equipment.

The LEI offers significant improvement over the previous alternatives. For example, if a digital “trunk-side” connection were used, such as with the DTI/PRI interface card, “lineside” functionality would not be supported. Previously, the only way to achieve lineside functionality was to use analog ports and channel bank equipment. With the LEI, a direct connection is provided to the IPE. No channel bank equipment is required, resulting in a more robust and reliable connection.

When used for connecting to third-party applications equipment, the LEI offers a number of benefits. It is a more cost-effective alternative for connection because it eliminates the need for expensive channel bank equipment. The LEI card supports powerful E1 monitoring, and diagnostic capability. Overall costs for customer applications may also be reduced because the E1-compatible IPE is often more attractively priced than the analog-port alternatives.

The LEI is compatible with all IPE-based systems and with standard public or private CEPT-type carrier facilities. It supports CRC-4- or FAS-only framing formats as well as AMI or HDB3 coding. Because it uses standard PCM in standard E1 timeslots, existing E1 test equipment remains compatible for diagnostic and fault isolation purposes. A/B Bit signaling may be customized according to the user’s system, including the Australian P2 signaling scheme.

## Card interfaces

The LEI passes voice and signaling data over DS-30X loops through the DS-30X Interface circuits and maintenance data over the card LAN link.

## **E1 interface circuit**

The LEI contains one E1 line-interface circuit which provides 30 individually configurable voice interfaces to one E1 link in 30 different time slots. The circuit demultiplexes the 2.56 Mbps DS-30X transmit signaling bitstreams from the DS-30X network loop and converts it into 2.048 MHz E1 transmit signaling bitstreams onto the E1 link. It also does the opposite, receiving receive signaling bitstreams from the E1 link and transmitting receive signaling bitstreams onto the DS-30X network loop.

The E1 interface circuit provides the following:

- An industry standard CEPT (0 to 655 feet) interface
- DS-30X signaling protocol into FXO A- and B-channel-associated signaling protocol
- Switch-selectable transmission and reception of E1 signaling messages over an E1 link in either loop or ground start mode
- Switch-selectable call processing between the Australian P2, North American Standard, or other user-configurable schemes

## **Signaling and control**

The LEI also contains signaling and control circuits that establish, supervise, and take down call connections. These circuits work with the system controller to operate the E1 line interface circuit during calls. The circuits receive outgoing call signaling messages from the controller and return incoming call status information to the controller over the DS-30X network loop.

## **Card control functions**

Control functions are provided by a microcontroller and a card LAN link on the LEI. A sanity timer is provided to automatically reset the card if the microcontroller stops functioning for any reason.

### **Microcontrollers**

The LEI contains a microcontroller that controls the internal operation of the card and the serial card LAN link to the controller card. The microcontroller controls the following:

- reporting to the CE CP through the card LAN link

- card identification (card type, vintage, serial number)
- firmware version
- self-test results
- programmed unit parameter status
- receipt and implementation of card configuration
  - control of the E1 line interface
  - enabling/disabling of individual units or entire card
  - programming of loop interface control circuits for administration of channel operation
  - maintenance diagnostics
- interface with the line card circuit
  - converts on/off-hook, and ringer control messages from the DS-30X loop into A/B bit manipulations for each time slot in the E1 data stream, using channel associated signaling.
- the front panel LED when the card is enabled or disabled by instructions from the NT8D01 controller card.

### **Card LAN interface**

Maintenance data is exchanged with the Common Equipment CPU over a dedicated asynchronous serial network called the Card LAN link. The Card LAN link is described in “Card LAN link” on [page 36](#).

### **Sanity Timer**

The LEI also contains a sanity timer that resets the microcontroller in the event of a loss of program control. If the timer is not properly serviced by the microcontroller, it times out and causes the microcontroller to be hardware-reset. If the microcontroller loses control and fails to service the sanity timer at least once per second, the sanity timer will automatically reset the microcontroller, restoring program control.

### **Man-Machine Interface**

The LEI provides an optional Man-Machine Interface (MMI) that is primarily used for E1 link performance monitoring and problem diagnosis. The MMI

provides alarm notification, E1 link performance reporting, and fault isolation testing. The interface is accessed through connections from the I/O panel to a terminal or modem. Multiple cards (up to 64) can be served through one MMI terminal or modem by linking the LEIs through a daisy chain.

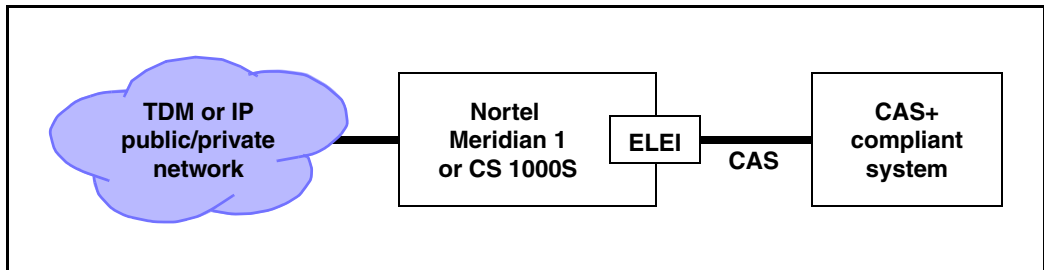
The MMI is an optional feature, since all E1 configuration settings are performed through dip switch settings or preconfigured factory default settings. Available MMI commands, and their functionality, are discussed in-depth in “Man-Machine E1 maintenance interface software” on [page 284](#).

## ELEI additional functionality

As mentioned earlier, ELEI cards are enhanced to allow CAS+ compliance, as shown in Figure 43. This enhancement provides several additional benefits for systems with ELEI cards installed.

*Note:* MDECTS and ELEI (operating in enhanced mode) cannot be configured on the same system.

**Figure 43**  
**CAS+ compliance**



Key Benefits of using CAS+ signaling (ELEI mode) over traditional A/B bit signaling (LEI mode) include:

**1** Calling Line ID Presentation (CLIP)

When an incoming call over the TDM/IP network or a CS 1000 originated call is directed towards the CAS+ compliant system, Calling Line ID can be provided over the CAS+ interface. This is assuming that the incoming call has the CLID without any presentation restrictions.

**2 Redirecting Line ID Presentation (RLIP)**

When an incoming call over the TDM/IP network or a CS 1000 originated call which has undergone redirections is directed towards the CAS+ compliant system, Redirecting Line ID can be provided over the CAS+ interface. This is assuming that the incoming call has the Redirecting Line ID without any presentation restrictions.

**3 Message waiting indication (MWI)**

Message waiting indication can be provided over the CAS+ interface.

## Electrical specifications

Table 93 provides a technical summary of the E1 line interface. Table 94 on [page 262](#) lists the maximum power consumed by the card.

### E1 channel specifications

Table 93 provides specifications for the 30 E1 channels. Each characteristic is set by a dip switch. See “Installation and Configuration” on [page 263](#) for a discussion of the corresponding dip switch settings.

**Table 93**  
**LEI card — line interface unit electrical characteristics**

Characteristics	Description
Framing	CRC-4 or FAS, only
Coding	AMI or HDB3
Signaling	Loop or ground start A/B robbed-bit
Distance to LTU	0-199.6 meters (0-655 feet)

## Power requirements

Table 94 shows the voltage and maximum current that the LEI requires from the backplane. One NT8D06 IPE Power Supply AC or NT6D40 IPE Supply DC can supply power to a maximum of eight LEIs.

**Table 94**  
LEI card – power required

Voltage	Max. Current
5.0 V dc	1.6 Amp
+15.0 V dc	150 mA
-15.0 V dc	150 mA

## Foreign and surge voltage protections

In-circuit protection against power line crosses or lightning strikes is not provided on the LEI. It does, however, have protection against accidental shorts to  $-52$  V dc analog lines.

When the card is used to service off-premise terminal equipment through the public telephone network, install a Line Termination Unit (LTU) as part of the terminal equipment to provide external line protection.

## Environmental specifications

Table 95 shows the environmental specifications of the LEI.

**Table 95**  
LEI card – environmental specifications (Part 1 of 2)

Parameter	Specifications
Operating temperature – normal	15° to +30° C (+59° to 86° F), ambient
Operating temperature – short term	10° to +45° C (+50 to 113° F), ambient
Operating humidity – normal	20% to 55% RH (non-condensing)
Operating humidity – short term	20% to 80% RH (non condensing)

**Table 95**  
**LEI card – environmental specifications (Part 2 of 2)**

Parameter	Specifications
Storage temperature	–50° to + 70° C (–58° to 158° F), ambient
Storage humidity	5% to 95% RH (non-condensing)

## Installation and Configuration

Installation and configuration of the LEI consists of six basic steps:

- 1** Configure the dip switches on the LEI for the call environment.
- 2** Install the LEI into the selected card slots.
- 3** Cable from the I/O panel to the LTU, MMI terminal or modem (optional), external alarm (optional), and other LEIs for daisy chaining use of MMI terminal (optional).
- 4** Configure the MMI terminal.
- 5** Configure the LEI through the CS 1000 Release 4.5 software and verify self-test results.
- 6** Verify initial E1 operation and configure MMI (optional).

Steps 1-5 are explained in this section. Step 6 is covered in “Man-Machine E1 maintenance interface software” on [page 284](#).

Installation and configuration of the ELEI follows the same steps. If enhanced functionality is required, then one additional step is required:

- 7** The Meridian 1 line unit(s) associated with the lineside E1 must be programmed for wireless operation (set WTYP=DECT, and WRLS=Yes in LD 10) in non-concentrated mode. Refer to *Software Input/Output: Administration* (553-3001-311) details on LD 10.

### Dip switch settings

Begin the installation and configuration of the LEI by selecting the proper dip switch settings for the environment. The LEI contains two dip switches, each containing eight switch positions. They are located in the upper right corner

of the motherboard circuit card as shown in Figure 44 on [page 266](#). The settings for these switches are shown in Table 96 on [page 267](#) through Table 99 on [page 270](#).

When the LEI card is oriented as shown in Figure 44 on [page 266](#), the dip switches are ON when they are up, and OFF when they are down. The dip switch settings configure the card for the following parameters:

### **MMI port speed selection**

This dip switch setting selects the appropriate baud rate for the terminal or modem (if any) that is connected to the MMI.

### **Line Supervisory Signaling protocol**

The LEI is capable of supporting loop start or ground start call processing modes. Make the selection for this dip switch position based on what type of line signaling the Customer Premise Equipment (CPE) supports.

### **Address of LEI to the MMI**

The address of the LEI to the MMI is made up of two components:

- the address of the card within the shelf
- the address of the shelf in which the card resides

These two addresses are combined to create a unique address for the card. The MMI reads the address of the card within the shelf from the card firmware; the address of the shelf must be set by this dip switch.

The shelf address dip switch can be from 0 to 15, 16 being the maximum number of lineside E1 IPE shelves (a maximum of 64 LEI cards) capable of daisy chaining to a single MMI terminal. For ease, it is recommended that this address be set the same as the address of the peripheral controller identifier in LD 97 for type: XPE. However, this is not mandatory, and, since the dip switch is limited to 16, this will not always be possible.

### **E1 framing**

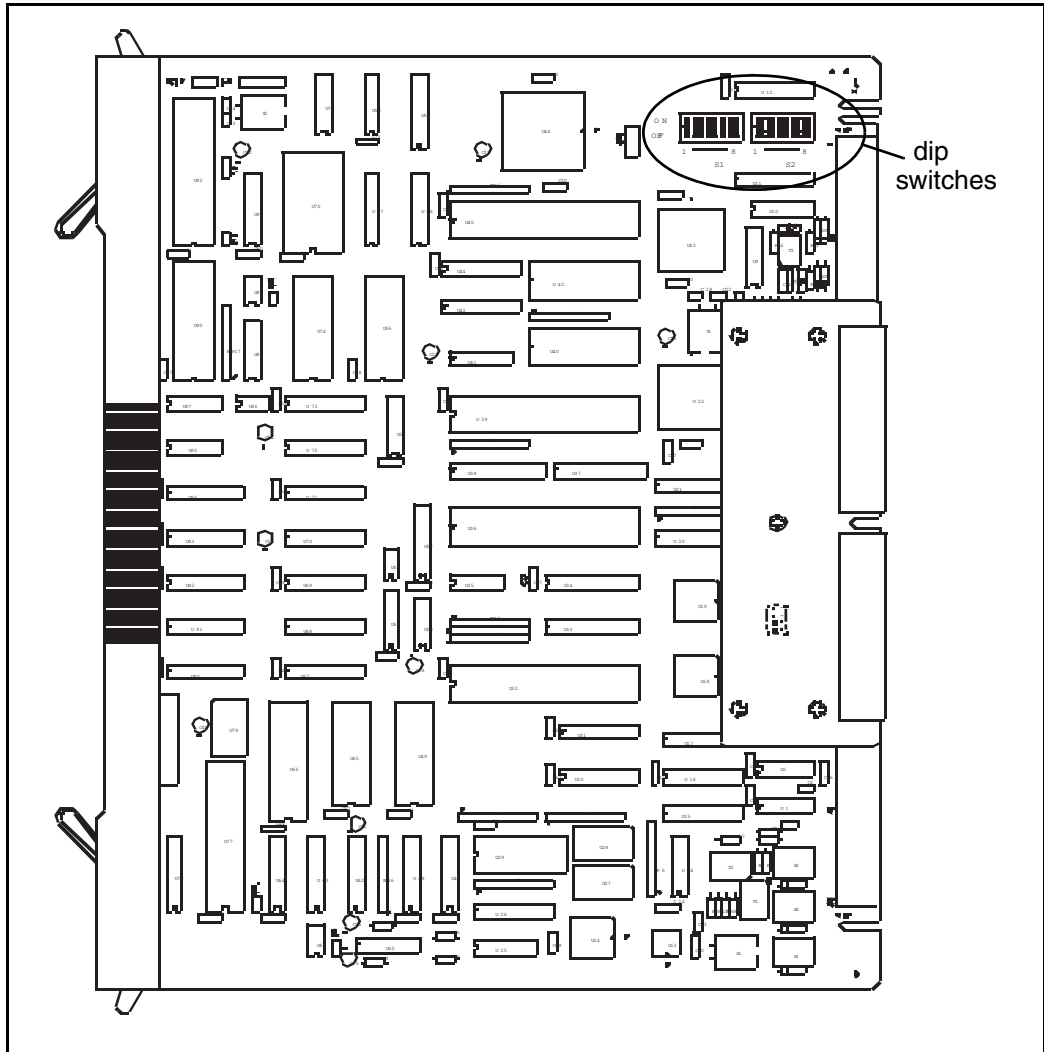
The LEI is capable of interfacing with LTU equipment either in CRC-4 or FAS only framing mode. Make the selection for this dip switch position based on what type of framing the LTU equipment supports.



### **E1 Coding**

The LEI is capable of interfacing with LTU equipment using either AMI or HDB3 coding. Make the selection for this dip switch position based on the type of coding the LTU equipment supports.

**Figure 44**  
**LEI card – E1 protocol dip switch locations**



**Line supervision on E1 failure**

This setting determines in what state all 30 LEI ports will appear to the CS 1000S, CS 1000M, and Meridian 1 in case of E1 failure. Ports can appear as either in the “on-hook” or “off-hook” states on E1 failure.

*Note:* All idle LEI lines will go off-hook and seize a Digitone Receiver when the off-hook line processing is invoked on E1 failure. This may prevent DID trunks from receiving incoming calls until the LEI lines time-out and release the DTRs.

**Daisy-Chaining to MMI**

If two or more LEIs will be installed and the MMI used, daisy-chain the cards together to use one MMI terminal or modem. Make the selection for this dip switch position based on how many LEIs are being installed.

**MMI Master or Slave**

This setting is used only if daisy-chaining the cards to the MMI terminal or modem. It determines whether this card is a master or a slave in the daisy chain. Select the master setting if there are no LEIs between this card and the MMI terminal or modem. Select the slave setting if there are other cards in the daisy chain between this card and the MMI.

Tables 96 through 98 show the dip switch settings for Switch #1. Table 99 on [page 270](#) shows the dip switch settings for Switch #2.

**Table 96**  
**LEI card – Switch #1 dip switch settings (Part 1 of 2)**

Characteristic	Selection	Switch Position	Switch Setting	Factory Default
MMI port speed selection	1200 baud	1	ON	OFF
	2400 baud	1	OFF	
E1 signaling	Ground start	2	ON	OFF
	Loop start	2	OFF	

**Table 96**  
**LEI card – Switch #1 dip switch settings (Part 2 of 2)**

Characteristic	Selection	Switch Position	Switch Setting	Factory Default
IPE Shelf address for LEI	See Table 98	3	See Table 98	OFF
		4		OFF
		5		OFF
		6		OFF
Card type for ringer allocation	XTI = 19 XMLC = 18	7	ON	OFF
		7	OFF	
E1 signaling	See Table 97	8	OFF	OFF

When dip switch #1, positions 2 and 8 are set to “Table,” AB Bits are configured by the user through the Set Mode MMI command (see “Set Mode” on [page 295](#)). Otherwise, the signaling scheme selected by dip switch 1, positions 2 and 8 will be used.

**Table 97**  
**LEI card – signaling-type dip switch settings**

Switch #1			
Characteristic	Selection	Position 2	Position 8
Signaling Type	Loop start	OFF	OFF
	Ground start	ON	OFF
	Australian P2	OFF	ON
	Table	ON	ON

**Table 98**  
**LEI card – XPEC address dip switch settings (Switch S1, positions 3-6)**

<b>XPEC Address</b>	<b>S1 Switch Position 3</b>	<b>S1 Switch Position 4</b>	<b>S1 Switch Position 5</b>	<b>S1 Switch Position 6</b>
00	OFF	OFF	OFF	OFF
01	ON	OFF	OFF	OFF
02	OFF	ON	OFF	OFF
03	ON	ON	OFF	OFF
04	OFF	OFF	ON	OFF
05	ON	OFF	ON	OFF
06	OFF	ON	ON	OFF
07	ON	ON	ON	OFF
08	OFF	OFF	OFF	ON
09	ON	OFF	OFF	ON
10	OFF	ON	OFF	ON
11	ON	ON	OFF	ON
12	OFF	OFF	ON	ON
13	ON	OFF	ON	ON
14	OFF	ON	ON	ON
15	ON	ON	ON	ON

When setting E1 Switch 2 dip switch settings, there are differences between vintages. For NT5D33AB or NT5D34AB cards, use Table 99. For NT5D33AC or NT5D34AC cards, use Table 99 on [page 270](#).

**Table 99**  
LEI card – E1 Switch 2 (S2) dip switch settings

Characteristic	Selection	Switch Position	Switch Setting	Factory Default
E1 framing	CRC-4 Disabled	1	ON	OFF
	CRC-4 Enabled		OFF	
E1 coding	AMI	2	ON	OFF
	HDB3		OFF	
NOT USED	leave ON	3	ON	ON
NOT USED	leave ON	4	OFF	OFF
NOT USED	leave ON	5	OFF	OFF
Line processing on E1 link failure	On-hook	6	ON	ON
	Off-hook		OFF	
Daisy-chaining to MMI	YES	7	ON	OFF
	NO		OFF	
MMI master or slave	Master	8	ON	ON
	Slave		OFF	

**Table 100**  
**ELEI card – E1 Switch 2 (S2) dip switch settings**

Characteristic	Selection	Switch Position	Switch Setting	Factory Default
E1 framing	CRC-4 Disabled	1	ON	<b>ON</b>
	CRC-4 Enabled		OFF	
E1 coding	AMI	2	ON	OFF
	HDB3		OFF	
NOT USED	leave ON	3	ON	ON
NOT USED	leave ON	4	OFF	OFF
<b>Mode</b>	<b>LEI Mode</b>	<b>5</b>	<b>OFF</b>	<b>OFF</b>
	<b>ELEI Mode</b>		<b>ON</b>	
Line processing on E1 link failure	On-hook	6	ON	<b>OFF</b>
	Off-hook		OFF	
Daisy-chaining to MMI	YES	7	ON	OFF
	NO		OFF	
MMI master or slave	Master	8	ON	ON
	Slave		OFF	

After the card has been installed, display the dip switch settings using the MMI command **Display Configuration (D C)**. See “Man-Machine E1 maintenance interface software” on [page 284](#) for details on this and the rest of the available MMI commands.

## Installation

Because of the wiring in some of the system modules and cabinets, the LEI will only work in certain card slot pairs. These restrictions depend on the type

of module or cabinet. In all other modules or cabinets where the conditions listed below do not exist, the LEI will work in any two adjacent card slots:

- In the NTAK12 Small Remote IPE Expansion Cabinet only card slots 10-15 are available.
- In the NT8D37 IPE module, if the 25-pair I/O connectors are partially split between adjacent IPE card slots, the LEI works only in card slots where Unit 0 of the motherboard card slot appear on the first pair of the 25-pair I/O connector.

If installing the LEI into the NT8D37 IPE module, determine the vintage level model. Certain vintage levels have dedicated 25-pair I/O connectors only for card slots 0, 4, 8, and 12. These vintage levels are cabled with only 16 pairs of wires from each card slot to the I/O panel. Some of the 25-pair I/O connectors are split between adjacent card slots.

Other vintage levels cable each card slot to the I/O panel using a unique, 24-pair connector on the I/O panel. In these vintage levels, the LEI can be installed in any available pair of card slots. However, because of the lower number of wire pairs cabled to the I/O panel in the lower vintage level, only certain card slots are available to the LEI.

See Table 101 for the vintage level information for the NT8D37 IPE modules.

**Table 101**  
**LEI card – NT8D37 IPE module vintage level port cabling**

Vintage Level	Number of ports cabled to I/O panel
NT8D37BA	30 ports
NT8D37DE	16 ports
NT8D37EC	30 ports

**Available and restricted card slots in the NT8D37 IPE module**

If installing the LEI into an NT8D37 IPE module, the card slots available depend on the vintage level module.



***Vintage levels cabling 30 ports:***

For modules with vintage levels that cabled 30 ports to the I/O panel, the LEI can be installed in any pair of card slots 0-15.

***Vintage levels cabling 16 ports:***

For modules with vintage levels that cable 16 ports to the I/O panel, the LEI can be installed into the card slot pairs shown in the following card slots:

Available:       Motherboard/Daughterboard  
                    0 and 1  
                    1 and 2  
                    4 and 5  
                    5 and 6  
                    8 and 9  
                    9 and 10  
                    12 and 13  
                    13 and 14

LEIs must **not** be installed into the following card slot pairs:

Restricted:       Motherboard/Daughterboard  
                    2 and 3  
                    3 and 4  
                    6 and 7  
                    10 and 11  
                    11 and 12  
                    14 and 15

If the LEI must be installed into one of the restricted card slot pairs, rewire the IPE module card slot to the I/O panel by installing an additional NT8D81 cable from the LEI motherboard slot to the I/O panel, and re-arranging the three backplane connectors for the affected card slots. This will permit the connection of the NT5D35AA or NT5D36AA LEI card carrier and maintenance external I/O cable at the IPE and CE module I/O panel connector for card slots that are otherwise restricted.

Alternatively, all LEI connections can be made at the main distribution frame instead of connecting the NT5D35AA or NT5D36AA LEI card external I/O cable at the I/O panel. This eliminates these card slot restrictions.

## Cabling the LEI card

After the dip switches are configured and the LEI installed into the selected card slots, the LEI can be cabled to the LTU equipment, the MMI terminal or modem (optional), an external alarm (optional), and other LEIs for daisy chaining use of the MMI terminal (optional).

The LEI is cabled from its backplane connector through connections from the motherboard circuit card only to the I/O panel on the rear of the IPE module. No cable connections are made from the daughterboard circuit card. The connections from the LEI to the I/O panel are made with the NT8D81AA Tip and Ring cables provided with the IPE module.

### **Cabling from the I/O panel with the NT5D35AA or NT5D36AA lineside E1 I/O cable**

In a twisted-pair E1 installation, make the connection from the I/O panel to the E1 link and other external devices with the NT5D35AA lineside E1 I/O cable.

This cable consists of a 25-pair amphenol connector (P1) on one end which plugs into the I/O panel. The other end has four connectors:

- 1 a DB15 male connector (P2), which plugs into the E1 line
- 2 a DB9 male connector (P3), which plugs into an external alarm system
- 3 a second DB9 male connector (P5), which connects to an MMI terminal or modem
- 4 a DB9 female connector (P4), which connects to the next LEI's P4 connector for MMI daisy chaining

In a coaxial E1 installation, make the connection from the I/O panel to the E1 link and other external devices through the NT5D36AA lineside E1 I/O cable.

This cable consists of a 25-pair amphenol connector (P1) on one end which plugs into the I/O panel. The other end has 4 connectors:

- 1 a DB15 female connector (P2) with an adapter that breaks out Tx (transmit) and Rx (receive) connectors, which that plug into the E1 line
- 2 a DB9 male connector (P3), which plugs into an external alarm system
- 3 a second DB9 male connector (P5), which connects to an MMI terminal or modem
- 4 a DB9 female connector (P4), which connects to the next LEI's P4 connector for MMI daisy chaining. The Tx marking on the adapter at P2 is the LEI output. The E1 data stream coming from the network into the LEI connects at the Rx coaxial connector

Table 102 shows the pin assignments of the LEI backplane and I/O Panel.

**Table 102**  
**LEI card – LEI backplane and I/O panel pinouts (Part 1 of 2)**

<b>Backplane connector pin</b>	<b>I/O Panel connector pin</b>	<b>Signal</b>
12A	1	E1 Tip, Receive data
12B	26	E1 Ring, Receive data
13A	2	E1 Tip, Transmit data
13B	27	E1 Ring, Transmit data
14A	3	Alarm out, normally open
14B	28	Alarm out, common
15A	4	Alarm out, normally closed
15B	29	No connection
16A	5	No connection
16B	30	Away from MMI terminal, receive data

**Table 102**  
**LEI card – LEI backplane and I/O panel pinouts (Part 2 of 2)**

Backplane connector pin	I/O Panel connector pin	Signal
17A	6	Away from MMI terminal, transmit data
17B	31	Toward MMI terminal, transmit data
18A	7	Toward MMI terminal, receive data
18B	32	Daisy chain control 2
19A	8	Daisy chain control 1
19B	33	Ground

Table 103 shows the pin assignments from the I/O panel relating to the pin assignments of the lineside E1 I/O cable.

**Table 103**  
**LEI card – lineside E1 I/O cable pinouts (Part 1 of 2)**

I/O Panel Connector Pin	Lead Designations	LEI Connect or Pin	LEI Cable Connector to External Equipment
1	E1 Tip Receive data	11	DB15 male to E1 (P2). LEI is CPE transmit and receive to network
26	E1 Ring Receive data	3	
2	E1 Tip Transmit data	1	
27	E1 Ring Transmit data	9	
3	Alarm out, common	1	
28	Alarm out (normally open)	2	DB9 male to external alarm (P3)

**Table 103**  
**LEI card – lineside E1 I/O cable pinouts (Part 2 of 2)**

<b>I/O Panel Connector Pin</b>	<b>Lead Designations</b>	<b>LEI Connect or Pin</b>	<b>LEI Cable Connector to External Equipment</b>
4	Alarm out (normally closed)	3	
7	Toward MMI terminal, receive data	2	DB9 male toward MMI (P5). Wired as DCE. Data is transmitted on pin 2 (RXD) and received on pin 3 (TXD)
31	Toward MMI terminal, transmit data	3	
33	Ground	5	
8	Control 1	7	
32	Control 2	9	
33	Ground	5	DB9 female away from MMI terminal (P4)
8	Control 1	7	
32	Control 2	9	
30	Away from MMI terminal, transmit data	3	
6	Away from MMI terminal, receive data	2	

**E1 Connections**

For twisted-pair installations, E1 signaling for all 30 channels is transmitted over P2 connector pins 1, 3, 9, and 11, as shown in Table 103 on [page 276](#).

Plug the DB 15 male connector labeled “P2” into the E1 link. E1 transmit and receive pairs must be turned over between the LEI and the CPE that is hardwired without carrier facilities. If the LEI is connected through E1 carrier facilities, the transmit and receive pairs must be wired straight through to the RJ48 at the Telco demarc, the LTU, or other E1 carrier equipment. The E1

CPE at the far-end will likewise have transmit and receive wired straight from the RJ48 demarc at the far-end of the carrier facility.

For 75 ohm coaxial installations, E1 signaling for all 30 channels is transmitted over P2 connector pins 1, 3, 9, and 11 through an adapter and out two coaxial connectors Tx (transmit) and Rx (receive). Tx is the LEI output, and Rx is the LEI input from the E1 stream. E1 transmit and receive pairs must be turned over between the LEI and the CPE that is hardwired without carrier facilities. If the LEI is connected through E1 carrier facilities, the transmit and receive pairs must be wired straight through to the RJ48 at the Telco demarc, the LTU, or other E1 carrier equipment. The E1 CPE at the far end will likewise have Tx and Rx wired straight from the RJ48 demarc at the far end of the carrier facility.

### **External Alarm Connections**

P3 connector pins 1, 2 and 3 can be plugged into any external alarm-sensing hardware. Plug the DB9 male connector labeled “P3” into an external alarm. These connections are optional, and the LEI functionality is not affected if they are not made.

The MMI monitors the E1 link for specified performance criteria and reports on problems detected. One of the ways it can report information is through this external alarm connection. If connected, the LEI’s microprocessor will activate the external alarm hardware if it detects certain E1 link problems it has classified as alarm levels 1 or 2. See “Man-Machine E1 maintenance interface software” on [page 284](#) for a detailed description of alarm levels and configuration. If an alarm level 1 or 2 is detected by the MMI, the LEI will close the contact that is normally open, and will open the contact that is normally closed. The MMI command “Clear Alarm” will return the alarm contacts to their normal state.

### **MMI Connections**

P5 connector pins 2, 3, 5, 7 and 9 are used to connect the LEI to the MMI terminal, connecting LEIs in a daisy chain for access to a shared MMI terminal. When logging into a LEI, “control 2” is asserted by that card, which informs all of the other cards not to talk on the bus, but rather to pass the data straight through. The pins labeled “control 1” are reserved for future use. As with the external alarm connections, MMI connections are optional. Up to

128 LEIs can be linked, located in up to 16 separate IPE shelves, to one MMI terminal using the daisy chain approach.

If only *one* LEI is will be installed, cable from the DB9 male connector labeled “P5” (toward MMI terminal) to one of the COM ports on the back of any TTY, a PC running a terminal emulation program, or a modem. For installations of only one card, no connection is made to the DB9 female connector labeled “P4” (away from MMI terminal).

If *two or more* LEIs are being installed into the system, the MMI port connections can be daisy-chained together so that only one MMI terminal is required for up to 128 LEIs. See Figure 45 on [page 280](#). Cards can be located in up to 15 separate IPE shelves. Start with any card slot in the IPE shelf and connect to any other card slot. Connected card slots do not need to be consecutive.

### **Procedure 13**

#### **Connecting two or more LEIs to the MMI terminal**

Follow this procedure for connecting two or more LEIs to the MMI terminal:

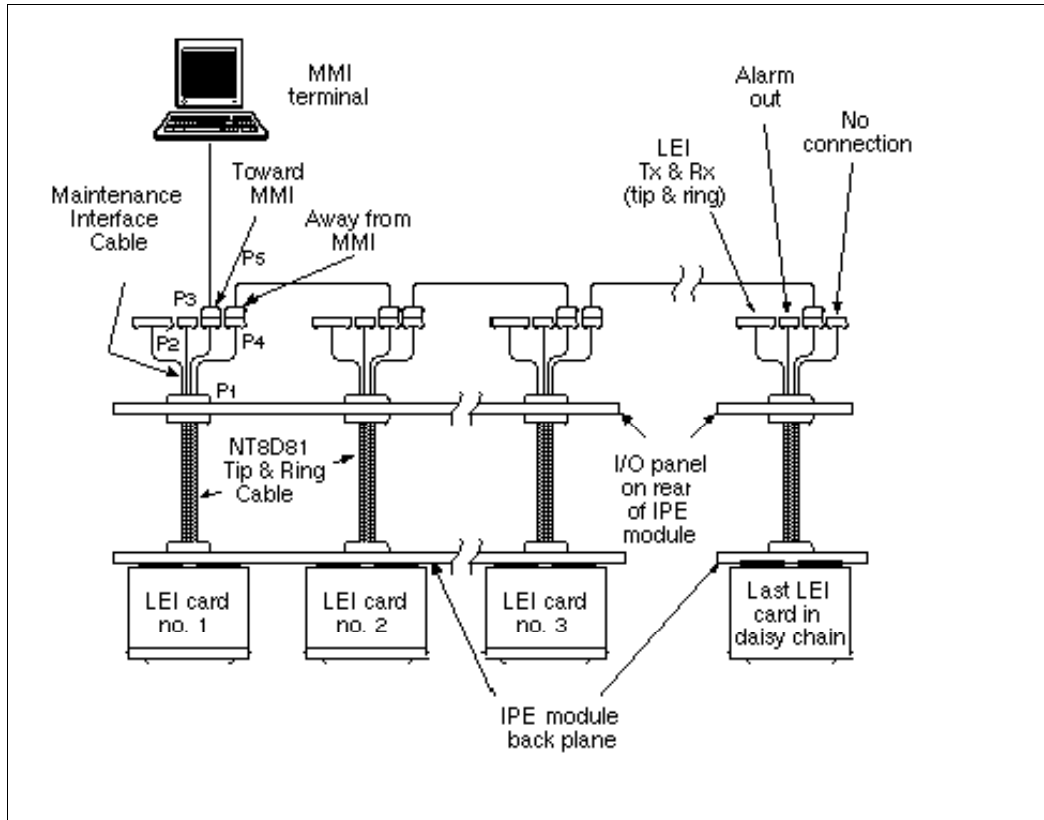
- 1** Cable the DB9 male connector labeled “P5” (toward MMI terminal) to one of the COM ports on the back of any TTY, a PC running a terminal emulation program, or a modem.
- 2** Make the connection from the first card to the second card by plugging the DB9 female connector labeled “P4” (away from MMI terminal) from the *first* card into the DB9 male connector of the second card labeled “P5” (toward MMI terminal).
- 3** Repeat step 2 for the remaining cards.
- 4** At the last card of the daisy chain, make no connection from the DB9 female connector labeled “P4” (away from MMI terminal).
- 5** If two LEIs are too far apart to connect the “P4” and “P5” connectors connect them with an off-the-shelf DB9 female to DB9 male straight-through extension cable, available at any PC supply store.

---

**End of Procedure**

---

**Figure 45**  
**LEI card – connecting two or more cards to the MMI**



### Terminal configuration

For the MMI terminal to be able to communicate to the LEI, the interface characteristics must be set to:

- speed – 1200 or 2400 bps
- character width – 7 bits
- parity bit – mark



- stop bits – one
- software handshake (XON/XOFF) – off

## Software Configuration

Although much of the architecture and many features of the LEI card are different from the analog line card, the LEI has been designed to emulate an analog line card to the CS 1000 Release 4.5 software. Because of this, the LEI software configuration is the same as for two adjacent analog line cards.

All 30 E1 channels carried by the LEI are individually configured using the analog (500/2500-type) Telephone Administration program LD 10. Use Table 104 to determine the correct unit number and *Software Input/Output: Administration* (553-3001-311) for LD 10 service-change instructions.

LEI circuitry routes 16 units (0 – 15) on the motherboard and 14 (0 – 13) units on the daughterboard to 30 E1 channels. The motherboard circuit card is located in the left card slot, and the daughterboard circuit card is located in right card slot. For example, if installing the LEI into card slots 0 and 1, the motherboard would reside in card slot 0 and the daughterboard would reside in card slot 1. In order to configure the terminal equipment through the switch software, the E1 channel number will need to be cross-referenced to the corresponding card unit number. This mapping is shown in Table 104.

**Table 104**  
**Card unit number to E1 channel mapping (Part 1 of 3)**

Item	TN	E1 Channel Number
Motherboard	0	1
Motherboard	1	2
Motherboard	2	3
Motherboard	3	4
Motherboard	4	5
Motherboard	5	6
Motherboard	6	7

**Table 104**  
**Card unit number to E1 channel mapping (Part 2 of 3)**

Item	TN	E1 Channel Number
Motherboard	7	8
Motherboard	8	9
Motherboard	9	10
Motherboard	10	11
Motherboard	11	12
Motherboard	12	13
Motherboard	13	14
Motherboard	14	15
Motherboard	15	17
Daughterboard	0	18
Daughterboard	1	19
Daughterboard	2	20
Daughterboard	3	21
Daughterboard	4	22
Daughterboard	5	23
Daughterboard	6	24
Daughterboard	7	25
Daughterboard	8	26
Daughterboard	9	27
Daughterboard	10	28
Daughterboard	11	29

**Table 104**  
**Card unit number to E1 channel mapping (Part 3 of 3)**

<b>Item</b>	<b>TN</b>	<b>E1 Channel Number</b>
Daughterboard	12	30
Daughterboard	13	31

### **Disconnect supervision**

The LEI supports far-end disconnect supervision by opening the tip side toward the terminal equipment upon the system's detecting a disconnect signal from the far-end on an established call. The Supervised Analog Line feature (SAL) must be configured in LD 10 for each LEI port. At the prompt FTR respond:

**OSP <CR>**

Against FTR respond:

**ISP <CR>**

The LEI treats OSP and ISP for both originating and terminating calls as hook flash disconnect supervision, also known as cut-off disconnect. Originating calls are outgoing from the terminal equipment. Terminating calls are incoming to the terminal equipment. The LEI does not support battery reversal answer and disconnect supervision on originating calls.

After the software is configured, power-up the card and verify the self-test results. The **STATUS** LED on the faceplate indicates whether or not the LEI has successfully passed its self test, and is, therefore, functional. When the card is installed, this LED remains lit for two to five seconds as the self-test runs. If the self-test completes successfully, the LED flashes three times and remains lit. When the card is configured and enabled in software, the LED goes out. The LED will go out if either the motherboard or daughterboard is enabled by the software. If the LED continually flashes or remains weakly lit, replace the card.

## Man-Machine E1 maintenance interface software

### Description

The Man-Machine Interface (MMI) provides E1-link diagnostics and historical information for the LEI system. See “Installation and Configuration” on [page 263](#) for instructions on how to install the cabling and configure the terminal for the MMI. The following sections will describe the options available through the LEI’s MMI terminal and will explain how to set-up, configure, and use the MMI.

The MMI provides the following maintenance features:

- configurable alarm parameters
- E1-link problem indicator
- current and historical E1-link performance reports
- E1 verification and fault isolation testing
- configuration of A/B bits (North American Standard, Australian P2, or customized settings are available)

### Alarms

The MMI may be used to activate alarms for the following E1-link conditions:

- excessive bit-error rate,
- frame-slip errors,
- out-of-frame,
- loss-of-signal, and
- blue alarm.

Pre-set thresholds and error durations trip LEI alarm notifications. For descriptions of each of these E1-link alarm conditions, see “Performance counters and reporting” on [page 304](#). For instructions on how to set alarm parameters, see “Set Alarm” on [page 290](#). For information on accessing alarm reporting, see “Display Alarms” on [page 302](#), “Display Status” on [page 303](#) and “Display Performance” on [page 305](#).

Two levels of alarm severity exist for bit errors. Different threshold and duration settings must be established for each level.

When the first level of severity is reached (alarm level 1), the MMI causes the following:

- the external alarm hardware activates
- the RED ALARM LED on the faceplate will be lit
- an alarm message will be displayed on the MMI terminal
- an entry will be created in the alarm log and printed to the MMI port

When the second level of severity is reached (alarm level 2), the MMI will perform all functions at alarm level 1. In addition, the LEI enters line-conditioning mode. In this mode, the LEI sends either “on-hook” or “off-hook” signals for all 30 ports to the CS 1000S, CS 1000M, and Meridian 1, depending on how the dip switch for line processing is set (dip switch 2, position 6). See Table 99 on [page 270](#).

If the MMI detects E1-link failures for any of the other conditions monitored (out-of-frame, excess frame slips, loss-of-signal, and blue alarm condition), the LEI automatically performs all alarm level 2 functions. The MMI also sends a yellow alarm to the far-end LTU. Alarms may be configured to self-clear when the alarm condition is no longer detected. See “Set Clearing” on [page 294](#).

All alarms activated produce a record in the alarm log. The alarm log maintains records for the most recent 100 alarms, and can be displayed, printed, and cleared. The alarm log displays or prints the alarms in descending chronological order, beginning with the most recent alarm. Notifications in the alarm log include the date and time of the alarm’s occurrence.

### **E1 Performance Counters and Reports**

The MMI maintains performance error counters for the following E1 conditions:

- errored seconds
- bursty seconds
- unavailable seconds

- framer-slip seconds
- loss-of-frame seconds

The MMI retains E1 performance statistics for the current hour, and for each hour for the previous 24. For descriptions of these performance error counters and instructions on how to create a report on them and clear them, see “Performance counters and reporting” on [page 304](#).

### **E1 Verification and Fault Isolation Testing**

The MMI enables various tests to be performed that either verify that the E1 is working adequately, or help to isolate a problem to the LEI, the E1 link, or the CPE. For descriptions of all of these tests and instructions on how to run them, see “Testing” on page 307.

## **Login and Password**

The MMI can be accessed through any TTY, PC running a terminal emulation program, or modem. After installing the MMI terminal and card cables, the MMI can be configured.

For single-card installations, it is accessed by entering **L<CR>** to login.

For multiple-card installations connected in a daisy chain, it is accessed by entering **L <address>**, where the four-digit address is a combination of the two-digit address of the IPE shelf as set by dip switch positions on the card Switch 1, positions 3-6, plus the address of the card slot the motherboard occupies. See Table 101 on [page 272](#).

For example, to login to a card located in shelf 13, card slot 4, type:

**L 13 4 <CR>**

Spaces are inserted between the login command (L), the shelf address, and the card slot address.

The MMI prompts for a password. The password is “**LEILINK**,” and it must be typed in all capital letters.

After logging in, the prompt looks like this:

**LEI::>** (for single-card installations)

**LEI:ss cc** (for multi-card installations, where ss represents the shelf address and cc represents the card slot address.)

## Basic commands

MMI commands can now be executed. The seven basic commands are:

- Help
- Alarm
- Clear
- Display
- Set
- Test
- Quit

Type **?<CR>** to list these commands, along with an explanation of their usage. A screen similar to Figure 46 will appear. The help screen will also appear by typing **H<CR>**, or **HELP<CR>**.

**Figure 46**  
**HELP (H, ?) screen**

```
ALARM  USAGE: Alarm [Enable | Disable]
CLEAR  USAGE: Clear [Alarm] | [Error counter] [Log]
DISPLAY USAGE: Display [Alarm | Status | Perform | History] [Pause]
HELP   USAGE: Help | ?
SET    USAGE: Set[Time | Date | Alarm | Clearing | Name Memory | Mode | Simple
TEST   USAGE: Test [Carrier All]
QUIT   USAGE: Quit

Notation Used:
CAPS - Required Letters      [ ] - Optional | - Either/Or
```

Each of these commands can be executed by entering the first letter of the command or by entering the entire command. Commands with more than one word are entered by entering the first letter of the first word, a space, and the first letter of the second word or by entering the entire command. Table 105 shows all possible MMI commands in alphabetical order. These commands are also described later in this section.

**Table 105**  
**MMI commands and command sets (Part 1 of 2)**

Command	Description
A D	<b>Alarm Disable.</b> Disables all alarms.
A E	<b>Alarm Enable.</b> Enables all alarms.
C A	<b>Clear Alarm.</b> Clears all alarms, terminates time processing, and resets the E1 bit error rate and frame slip counters.
C A L	<b>Clear Alarm Log.</b> Clears alarm log.
C E	<b>Clear Error.</b> Clears the E1 error counter.
D A(P)	<b>Display Alarms.</b> Displays the alarm log, which is a list of the 100 most recent alarms with time and date stamps. (Momentarily stop the scrolling display by typing P. Continue scrolling by typing any other key.)
D C(P)	<b>Display Configuration.</b> Displays the configuration settings for the LEI(s), single- or multiple-card system. Display includes each card's serial number, MMI firmware version, date and time, alarm disable/enable setting, self-clearing disable/enable setting, values entered through the Set Configuration command, and dip switch settings. (Momentarily stop the scrolling display by typing P. Continue scrolling by typing any other key.)
D H(P)	<b>Display History.</b> Displays performance counters for the past 24 hours. (Momentarily stop the scrolling display by typing P. Continue scrolling by typing any other key.)
D P	<b>Display Performance.</b> Displays performance counters for the current hour.



**Table 105**  
**MMI commands and command sets (Part 2 of 2)**

Command	Description
D S(P)	<b>Display Status.</b> Displays carrier status, including alarm state and, if active, alarm level. (Momentarily stop the scrolling display by typing P. Continue scrolling by typing any other key.)
H or ?	<b>Help.</b> Displays the Help screen.
L	<b>Login.</b> Logs into the MMI terminal in a single-LEI system.
Lxx	<b>Login.</b> Logs into the MMI terminal in a daisy-chained system, where xx represents the address of the card to be configured.
Q	<b>Quit.</b> Logs out of the MMI terminal.  <b>Note:</b> If it is a daisy-chained system, be certain to log out when finished with configuration. In a daisy-chained system, only one card may occupy the bus at a given time and all other LEIs will be unable to notify the MMI of alarms unless logged-out of configuration mode.
S A	<b>Set Alarm.</b> Sets alarm parameters, such as the allowable bit-errors per second, threshold, and alarm duration.
S C	<b>Set Clearing.</b> Sets the alarm self-clearing function, "enable" or "disable."
S D	<b>Set Date.</b> Sets the date or verifies the current date.
S M	<b>Set Mode.</b> Sets the A/B Bits mode.
S S	<b>Set Simple.</b> Sets whether or not the LEI waits for the terminal equipment to return an idle-state message before returning the channel to idle at call disconnect from the far-end.
S T	<b>Set Time.</b> Sets the time or verifies current time.
T	<b>Test.</b> Initiates the E1 carrier test function. To terminate a test in-process, enter the STOP TEST command at any time.

## Configuring parameters

The MMI has been designed with default settings so that no configuration is necessary. However, it can be configured based on the call environment.

### Set Time

Before beginning to configure the MMI, login to the system and verify the current time. Do this by entering the **Set Time (S T)** command. The MMI displays the time it has registered. Enter a new time or hit **Enter** to leave it unchanged. The time is entered in the “hh:mm:ss,” the 24-hour, or military, format.

### Set Date

Verify the current date. Do this by entering the **Set Date (S D)** command. The MMI then displays the date it has registered. Enter a new date or hit **Enter** to leave it unchanged. The date is entered in the “mm/dd/yy” format.

### Set Alarm

The **Set Alarm (S A)** command sets the parameters by which an alarm is activated and the duration of the alarm after it is activated. There are three alarm levels as described below:

- **Alarm Level 0 (AL0)** consists of activity with an error threshold below the AL1 setting, which is a satisfactory condition and no alarm is activated.
- **Alarm Level 1 (AL1)** consists of activity with an error threshold above the AL1 setting, but below the AL2 setting that is deemed to be of minor importance. In this situation, the external alarm hardware is activated by closing the normally open contact, the RED ALARM LED on the faceplate lights, and an alarm message is created in the alarm log and the MMI terminal.
- **Alarm Level 2 (AL2)** consists of activity with an error threshold above the AL2 setting which is deemed to be of major importance. In this situation, the following happens:
  - the external alarm hardware is activated by closing the normally open contact
  - the RED ALARM LED on the faceplate lights

- an alarm message is created in the alarm log and the MMI terminal
- the LEI card enters line-conditioning mode
- a yellow alarm message is sent to the CPE/LTU

Line processing sends the CS 1000S, CS 1000M, and Meridian 1 either all “on-hook” or all “off-hook” signals, depending on the dip switch setting of the card. See Table 99 on [page 270](#).

When the **Set Alarm** command is selected, the prompt appears for setting the threshold level and duration for alarm levels 1 and 2.

The E1 link processes at a rate of approximately 2.0 mb/s. The threshold value indicates the ratio of the total number of bits that must be detected as being in error per second before the LEI activates an alarm. It can be set between 3 and 9 and can be different for each alarm level. Any other value entered will cause the MMI to display a “Parameter Invalid” message. The digit entered as the threshold value is a number representing a negative power of 10 as shown in Table 106.

*Note:* The error-rate threshold for a level 2 alarm must be greater (a smaller power of 10) than for a level 1 alarm. Remember that the numbers being represented are negative numbers. Since 3 represents  $-3$ , and 4 represents  $-4$ , 4 represents a smaller number than 3 does.

**Table 106**  
**E1 bit error rate threshold settings (Part 1 of 2)**

Alarm threshold bit errors per second in power of 10	Threshold to set alarm	Allowable Duration Periods
$10^{-3}$	2,000/ second	1-21 seconds
$10^{-4}$	200/second	1-218 seconds
$10^{-5}$	20/second	1-2148 seconds
$10^{-6}$	2.0/second	1-3600 seconds
$10^{-7}$	2.0/10 seconds	10-3600 seconds

**Table 106**  
**E1 bit error rate threshold settings (Part 2 of 2)**

Alarm threshold bit errors per second in power of 10	Threshold to set alarm	Allowable Duration Periods
$10^{-8}$	2.0/100 seconds	100-3600 seconds
$10^{-9}$	2.0/1000 seconds	1000-3600 seconds

The duration value is set in seconds and can be set from 1 to 3,600 seconds (1 hour). This duration value indicates how long the alarm condition must last before an alarm will be declared. Low bit-error rates ( $10^7$  through  $10^9$ ) are restricted to longer durations since it takes more than one second to detect an alarm condition above  $10^6$ . Higher bit-error rates are restricted to shorter durations because the MMI error counter fills at 65,000 errors.

The alarm indications (LEDs and external alarm contacts) will clear automatically after the specified period, or duration, has expired if the **Set Clearing (S C)** “Enable Self Clearing” option has been set. Otherwise, the alarm will continue until the command **Clear Alarm (C A)** has been entered.

When an alarm is cleared, all activity caused by the alarm indications is cleared:

- the external alarm hardware is deactivated (the contact normally open will be reopened)
- the LED goes out
- an entry is made in the alarm log of the date and time the alarm was cleared
- carrier-fail line supervision ceases (for alarm level 2 only)

If self-clearing alarm indications have been disabled, carrier-fail line supervision terminates when the alarm condition has ceased, but the external alarm contact and faceplate LED remain active until the alarm is cleared.

A heavy bit-error rate can cause 200 bit errors to occur much more quickly than 100 seconds. This causes the alarm to be declared sooner.

An alarm condition is not automatically cleared until the system no longer detects the respective bit error threshold during the corresponding duration period.

For example, if AL1 threshold of 6 (representing 10-6) is specified, and a duration period of 100 seconds is specified, an alarm is activated if more than 200 bit errors occur in any 100 second period. As soon as the alarm is activated, the bit counter is reset to 0. If the next 100 seconds pass, and less than 200 bit errors are detected, then the alarm clears after the alarm's duration period. However, if more than 200 bit errors are detected in the next 100 seconds, the alarm condition continues for the designated time period.

The alarm finally clears when the alarm condition is no longer detected for the designated period, either by self-clearing (if this function is enabled), or when the **Clear Alarm (C A)** command is entered.

In addition to bit errors, the Set Alarm function sets parameters for detecting frame-slip errors by establishing a threshold necessary to activate an alarm. If the threshold value is exceeded, a level 2 alarm is activated. The frame slip threshold can be specified from 1 to 255 frame slips per time period. The duration time period can be specified from 1 to 24 hours.

When entering the **Set Alarm (S A)** command, the MMI scrolls through the previously described series of alarm options. These options are displayed along with their current value, at which point a new value can be entered or enter <CR> to retain the current value. Table 107 outlines the options available in the **Set Alarm (S A)** function.

**Table 107**  
**Set alarm options (Part 1 of 2)**

<b>Option</b>	<b>Description</b>
AL1 Threshold	Sets the allowable bit errors per second before alarm level 1 is activated. Factory default is 6.
AL1 Duration	Sets the duration in seconds (from 1 to 3,600 seconds) that alarm level 1 is activated. Factory default is 10 seconds.

**Table 107**  
**Set alarm options (Part 2 of 2)**

Option	Description
AL2 Threshold	Sets the allowable bit errors per second (from 3 to 9) before alarm level 2 is activated. Factory default is 10 <sup>-5</sup> .
AL2 Duration	Sets the duration in seconds (from 1 to 3,600 seconds) that alarm level 2 is activated. Factory default is 10 seconds.
Frame Slip Threshold	Sets the allowable frame slips per time period (from 1 to 255) before alarm level 2 is activated. Factory default is 5.
Frame Slip Duration	Sets the duration in hours (from 1 to 24) that the frame slips are counted. After this time period, the counter is reset to 0. Factory default is 2 hours.

*Note:* If the duration period set is too long, the LEI card is slow to return to service automatically even when the carrier is no longer experiencing errors. The **CLEAR ALARM (C A)** command has to be entered manually to restore service promptly. To avoid this, an alarm’s duration period is normally set to 10 seconds.

### Set Clearing

The **SET CLEARING (S C)** command allows self-clearing of alarms by responding to the question: **Enable Self Clearing? (YES or NO)**. If **YES** is chosen (the factory default setting), the system automatically clears (resets) alarms after the alarm condition is no longer detected. Choosing the **NO** option causes the system to continue the alarm condition until the **Clear Alarm (C A)** command is entered. Line processing and yellow alarm indication to the CPE terminates as soon as the alarm condition clears, even if self-clearing is disabled.

### Set Simple

The **SET SIMPLE** command controls call tear-down signaling when the far-end disconnects from a call.

When the far-end terminates a call, Release 1 of LEI's AB vintage sends a disconnect message to the terminal equipment and waits for the terminal equipment to go idle before going idle itself. A **NO** response to the **S S** command configures Release 2 (and later) boards to operate in this way. See Figure 47.

Release 2 of AB vintage LEIs gives the administrator the option of using the signaling described above, or configuring the LEI to take its channel idle immediately after sending the call-disconnect message. A **YES** response to the **S S** command, the default configuration for Release 2 (and later) boards, configures the LEI to operate in this way. See Figure 48.

**Figure 47**  
**Set Simple (S S) no screen**

```
LEI::>S S
Enable Simplified Call Tear Down? (YES or NO)N
Simplified Call Tear Down Disabled.
LEI::>
```

**Figure 48**  
**Set Simple (S S) yes screen**

```
LEI::>S S
Enable Simplified Call Tear Down? (YES or NO)Y
Simplified Call Tear Down Enabled.
LEI::>
```

### **Set Mode**

At the **SET MODE (S M)** command, the MMI prompts the user with the current signaling mode, either Default (Australian P2) or Table (of bit values.) Entering a **<CR>** accepts the current value, or the user can type in 1 to revert to the Default, or 2 to edit the table entries. See Figure 49 on [page 296](#). If the user selects default, then the A/B Bit values is reset to the Default values.

Responding to the MMI's **Set Mode** prompt with "1" also results in the line, "**Signaling Bits set to Default,**" as in Figure 49.

**Figure 49**  
**Set Mode (S M): <CR> screen**

```
LEI:>S M
1) Default
2) Table
Hit <CR> to accept current value or type in a new one.
Current Mode : 1          New Mode :
Signaling Bits set to Default.

LEI:>
```

However, responding to this prompt with **2** selects “Table” and allows the user to set the A/B Bit Mode to whatever configuration the user chooses.

If “Table” is selected, the individual table values will be prompted for. See Figure 50 on [page 297](#) and Figure 51 on [page 298](#). After each value is displayed, enter **<CR>** to do the following:

- accept the current value
- enter just the AB bits (which will be copied to the CD bits)
- enter a complete ABCD bit pattern
- in the case of optional states, a ‘N’ or ‘n’ can be entered to indicate that the state is not needed

Note that in D4 Framing for E1, there are no CD bits, so they will be ignored.

The user is prompted for ABCD bit values for the following states when the table mode is selected.

Send and Receive refer to the LEI sending ABCD bits to the CPE (Customer Provided Equipment) or receiving ABCD bits from the CPE.

Incoming and Outgoing refer to E1 digital link from the CPE point of view. Incoming is thus an external call arriving over the digital link and accepted by the CPE. Outgoing is a call originated by the CPE over the digital link.

Configuring the A/B Bit Signaling table is illustrated in Figure 50 and Figure 51 on [page 298](#).



**Figure 50**  
**Set Mode (S M): Table screen**

```
Outgoing call SEIZE RECEIVE: Current: 0001 New: 111
Error: Note enough values specified. Enter either 2 or 4
values.
Outgoing call SEIZE RECEIVE: Current: 0001 New: 11
Outgoing call SEIZE RECEIVE bits changed to: 1111

Outgoing call SEIZE ACK SEND enabled? (Y/N): N
Outgoing call SEIZE ACK SEND is disabled.

Outgoing call DIAL MAKE RECEIVE: Current: 1111 New:
Outgoing call DIAL MAKE RECEIVE bits not changed.

Outgoing call DIAL BREAK RECEIVE: Current: 1010 New:
Outgoing call DIAL BREAK RECEIVE bits not changed.

Outgoing call ANSWERED SEND: Current: 0101 New:
Outgoing call ANSWERED SEND bits not changed.

Outgoing call (CPE) DISCONNECT RECEIVE: Current: 0101 New:
Outgoing call (CPE) DISCONNECT RECEIVE bits not changed.

Outgoing call (Far End) DISCONNECT SEND: Current: 1111 New:
Outgoing call (Far End) DISCONNECT SEND bits not changed.

Disconnect Time (0 to 4000 ms): 1000
Disconnect Time not changed.

Intercall Time (0 to 2000 ms): 800
Intercall Time not changed.

LEI:>
```

**Idle SEND** – This is the value that the LEI sends (acting as the CO or PSTN) when the circuit is in the idle state. This value is required.

**Idle RECEIVE** – This is the value that the LEI expects to see from the CPE when it is in the idle state. This value is required.

**Blocking RECEIVE** – This is the value that the LEI expects to see from the CPE when the customer equipment is in the blocking or fault state and is

Figure 51  
Set Mode (S M): Table screen

```
LEI:>S M
1) Default
2) Table
Hit <CR> to accept current value or type in a new one.
Current Mode : 1          New Mode : 2
Signaling Bits set to Table.

Incoming and outgoing calls are in reference to the CPE.
All ABCD bits are with respect to SENDING from LEI/M1 to CPE
or RECEIVING from CPE to LEI/M1.
Please enter new ABCD bits or hit <CR> to accept. You may
enter 2 or 4 values. If only 2 values are entered, the A and
B bits will be copied to the C and D bits.

IDLE SEND: Current: 0000 New: 0101
IDLE SEND bits changed to: 0101

IDLE RECEIVE: Current: 0101 New:
IDLE RECEIVE bits unchanged.

BLOCKING RECEIVE enabled? (Y/N): N
BLOCKING RECEIVE is disabled.

Incoming call RINGER-ON SEND: Current: 0000 New:
Incoming call RINGER-ON SEND bits not changed.

Incoming call RINGER-OFF SEND: Current: 0101 New: 0101
Incoming call RINGER-OFF SEND bits not changed.

Incoming call OFFHOOK RECEIVE: Current: 1111 New: 11
Incoming call OFFHOOK RECEIVE bits not changed.

Incoming call CONNECTED SEND: Current: 0101 New:
Incoming call CONNECTED SEND bits not changed.

Incoming call (Far End) DISCONNECT SEND: Current: 1111 New:
Incoming call (Far End) DISCONNECT SEND bits not changed.

Incoming call (CPE) DISCONNECT RECEIVE: Current: 0101 New:
Incoming call (CPE) DISCONNECT RECEIVE not changed.
```

unable to accept new calls. Set this value to N if this state is not needed. If this value is not set to N, then dip switch #2 position 6 will determine whether off-hook or on-hook is sent to the M1/SL100 when this state is entered. See Table 99 on [page 270](#).

**Incoming call Ringer ON SEND** – This is the value that the LEI sends to indicate that a call is incoming to the CPE and that ringing voltage should be applied at the CPE. This value is required.

**Incoming call Ringer OFF SEND** – This is the value that the LEI sends to indicate that a call is incoming to the CPE and that the ring cycle is in the off portion of the cadence. This value is required.

**Incoming call Offhook RECEIVE** – This is the value that the LEI expects to see from the CPE when the customer equipment has gone to an off hook state which indicates that the incoming call has been answered. This value is required.

**Incoming call CONNECTED SEND** – This is the value that the LEI sends to the CPE to indicate that it has seen and recognized the off hook indication sent by the CPE. The call is considered fully connected at this point. This value is required.

**Incoming call (Far-end) DISCONNECT SEND** – This is the value that the LEI sends to indicate that the far-end has released the call. This value is required.

**Incoming call (CPE) DISCONNECT RECEIVE** – This is the value that the LEI expects to see from the CPE when the customer equipment wishes to end the call. This value is required.

**Outgoing call SEIZE RECEIVE** – This is the value that the LEI expects to see when the CPE goes to an off hook condition and wishes to initiate a call. This value is required.

**Outgoing call SEIZE ACK SEND** – This is the value that the LEI will send to indicate that the seized condition has been noted and the M-1 is ready for dial digits. This value can be set to N if it is not required such as in a loop start case.

**Outgoing call DIAL MAKE RECEIVE** – This is the value that the LEI expects to see from the CPE during the make part of the digit. This value is required.

**Outgoing call DIAL BREAK RECEIVE** – This is the value that the LEI expects to see from the CPE during the break part of the digit. This value is required.

**Outgoing call ANSWERED SEND** – This is the value that the LEI will send to indicate that the far-end has answered the call. This value is required.

**Outgoing call (CPE) DISCONNECT RECEIVE** – This is the value that the LEI expects to see from the CPE when the customer equipment wishes to end the call. This value is required.

**Outgoing call (Far-end) DISCONNECT SEND** – This is the value that the LEI will send to indicate that the far-end has released the call. This value is required.

**Disconnect Time** – This is the number of milliseconds that the LEI will send the disconnect signal to the CPE before reverting to the idle state. If the CPE reverts to a connected state during this time, it is ignored. This value is only used when disconnect supervision is available and is needed for the signaling type in use. It is used when the far-end initiates the disconnect. For loop start cases, this value is not used.

**Intercall (release guard) Time** – This is the number of milliseconds that the LEI maintains the idle signal to the CPE before initiating a new call. The CPE should not initiate a new call during this time. If it does so, the off-hook indication is ignored until the release guard time has expired. This value defaults to 0 which relies on the M-1 to observe the proper guard time. If a non-zero value is entered, off-hook from the CPE and Ringer-On commands from the M1/SL100 is ignored until this timer has expired.

### **Display Configuration (D C)**

The **Display Configuration (D C)** command displays the various configuration settings established for the LEI. Entering this command causes a screen similar to Figure 52 to appear.

**Figure 52**  
**Display Configuration (D C) screen**

```
LEI S/N 1103 Software Version 1.01 3/03/95 1:50
Alarms Enabled: YES Self Clearing Enabled: YES
Alarm Level 1 threshold value: E-7 Threshold duration (in
seconds): 10
Alarm Level 2 threshold value: E-5 Threshold duration (in
seconds): 1
Frame slips alarm level threshold: 5 Threshold duration (in hours)
2
Current dip switch S1 settings (S1..S8) On Off Off On Off Off Off On
Current dip switch S2 settings (S1..S8) On Off On Off Off Off On Off
```

## Alarm operation and reporting

The MMI monitors the E1 link according to parameters established through the Set Alarm command for the following conditions:

- Excessive bit error rate
- Frame slip errors
- Out of frame condition
- Loss of signal condition
- Blue alarm (AIS) condition

Descriptions of the excessive bit error rate and frame slip errors conditions are found in “Configuring parameters” on page 290. Bit errors activate either a level 1 or level 2 alarm. The remaining conditions, when detected, always cause the system to activate a level 2 alarm.

An out-of-frame condition will be declared if 3 consecutive frame bits are in error. If this condition occurs, the hardware immediately attempts to reframe. During the reframe time, the E1 link is declared out-of-frame, and silence is sent on all receive timeslots.

A loss of signal condition is declared if a full frame (255 bits) of consecutive zeros has been detected at the receive inputs. If this condition occurs, the E1 link automatically attempts to resynchronize with the far-end. If this condition lasts for more than two seconds, a level 2 alarm is declared, and silence is sent on all receive timeslots. The alarm is cleared if, after two

seconds, neither a loss of signal, out-of-frame condition, or blue alarm condition occurs.

If a repeating device loses signal, it immediately begins sending an unframed signal of all ones to the far-end to indicate an alarm condition. This condition is called a blue alarm, or an Alarm Indication Signal (AIS). If an AIS is detected for more than two seconds, a level 2 alarm is declared, and silence is sent on all receive timeslots. The alarm is cleared if, after two seconds, neither a loss of signal, out-of-frame condition, or blue alarm condition occurs.

### **Alarm Disable**

The **Alarm Disable (A D)** command disables the external alarm contacts. When this command is typed, the MMI displays the message **Alarms Disabled** and the MAINT LED lights. In this mode, no yellow alarms are sent and the LEI does not enter line processing mode. Alarm messages are sent on the MMI terminal and the LED continues to indicate alarm conditions.

### **Alarm Enable**

The **Alarm Enable (A E)** command does the reverse of the **Alarm Disable (A D)** command. It enables the external alarm contacts. When this command is typed in, the MMI will display the message **Alarms Enabled**. In this mode, yellow alarms can be sent and the LEI can enter line processing mode.

### **Clear Alarm**

The **Clear Alarm (C A)** command clears all activity initiated by an alarm: the external alarm hardware is deactivated (the contact normally open is reopened), the LED goes out, an entry is made in the alarm log of the date and time the alarm was cleared, and line processing ceases (for alarm level 2 only). When this command is typed, MMI displays the message **Alarm acknowledged**. If the alarm condition still exists, an alarm is declared again.

### **Display Alarms**

A detailed report of the most recent 100 alarms with time and date stamps can be displayed by entering the **Display Alarms (D A)** command into the MMI, which will cause a screen similar to Figure 53 on [page 303](#) to appear.

**Figure 53**  
**Display Alarm (D A) screen**

```
Alarm Log
2/03/99  1:48  Yellow alarm on E1 carrier
2/03/99  2:33  E1 carrier level 1 alarm
2/03/99  3:47  E1 carrier level 2 alarm
2/03/99  4:43  E1 carrier performance within thresholds
2/03/99 15:01 Log Cleared
```

The Pause command can be used to display a full screen at a time, by entering **D A P**. If there is more than one screen in the log, the MMI scrolls the log until the screen is full, then stops. When ready to see the next screen, press any key. The display shows another screen and stops again. This continues until the entire log has been displayed.

### **Clear Alarm Log**

Clear all entries in the alarm log by typing the **Clear Alarm Log (C A L)** command.

### **Display Status**

The **Display Status (D S)** command displays the current alarm condition of the E1 link as well as the on-hook or off-hook status of each of the 30 ports of the LEI. Entering this command causes a screen similar to Figure 54 on [page 304](#) to appear.

The Pause command can be used to display a full screen at a time, by entering **D S P**. If there is more than one screen, the MMI scrolls until the screen is full, then stops. When ready to see the next screen, press any key. The display shows one more screen, and stops again. This continues until the entire E1 link has been reported on.

**Figure 54**  
**Display Status (D S) screen**

```
LEI S/N Software Version 1.01 3/03/95 1:50
In alarm state: NO
E1 link at alarm level 0
Port 0 off hook, Port 1 on hook, Port 2 on hook, Port 3 on hook,
Port 4 on hook, Port 5 on hook, Port 6 off hook, Port 7 off hook,
Port 8 off hook, Port 9 on hook, Port 10 on hook, Port 11 on hook,
Port 12 off hook, Port 13 on hook, Port 14 on hook, Port 15 on hook,
Port 16 on hook, Port 17 on hook, Port 18 off hook, Port 19 off hook,
Port 20 off hook, Port 21 on hook, Port 22 on hook, Port 23 on hook
Port 21 off hook, Port 22 on hook, Port 23 on hook, Port 24 on hook,
Port 25 on hook, Port 26 on hook, Port 27 off hook, Port 28 off hook,
Port 29 off hook
```

## Performance counters and reporting

The MMI monitors the performance of the E1 link according to several performance criteria including errored, bursty, unavailable, loss-of-frame and frame-slip seconds. It registers the performance of these criteria by reading their status every second and counting their results. These counts are accumulated for an hour, then reset to 0. Previous hour count results are maintained for each of the previous 24 hours.

The LEI counts CRC-4 errors when CRC-4 is enabled and Bipolar Violations (BPV) when CRC-4 is disabled. The performance criteria for which these counts are maintained as follows:

- Errored seconds are seconds in which one or more CRC-4 / BPV errors, or one or more out-of-frame errors in one second.
- Bursty seconds are seconds in which more than one and less than 320 CRC-4 / BPV errors in a second.
- Severely errored seconds are seconds in which more than 320 CRC-4 / BPV errors, or one or more out-of-frames in a second.
- Unavailable seconds are seconds in which unavailable state starts with 10 consecutive severely errored seconds and ends with 10 consecutive non-severely errored seconds (excluding the final 10 non-severely errored seconds).



- Loss-of-frame seconds are seconds in which loss-of-frame or loss-of-signal conditions have existed for three consecutive seconds.
- Frame slip seconds are seconds in which one or more frame slips occur.

The MMI also maintains an overall error counter which is the sum of all errors counted for the performance criteria listed above. The error counter can only be cleared by entering the **Clear Error (C E)** command. It stops counting at 65,000. The error counter provides an easy method to determine if an alarm condition has been corrected. Clear the error counter, wait a few minutes, and display the performance to see if any errors have occurred since the counter was cleared.

The MMI display reports on these performance counters through the **Display Performance (D P)** or the **Display History (D H)** commands.

### Display Performance

Entering the **Display Performance (D P)** command displays performance counters for the past hour. A screen similar to Figure 55 will appear.

**Figure 55**  
**Display Performance (D P) screen**

LEI E1 Interface Performance Log					
3/03/95 1:37 PM					
Data for the past 37 Minutes					
Errored Seconds	Bursty Seconds	Unavailable Seconds	Loss Frame Seconds	Frame Slip Seconds	Error Counter
2263	0	2263	2263	352	321

Each column, except the error counter, indicates the number of errors in the current hour and is reset to zero every hour on the hour. Just before the performance counters are reset to zero, the values are put into the history log.

The error counter indicates the number of errors since the error counter was cleared.

The Pause command can be used to display a full screen at a time, by entering **D P P**. If more than one screen is to be displayed, the MMI scrolls until the screen is full, then stops. When ready to see the next screen, press any key. The display shows one more screen, and stops again. This continues until the entire display has been shown.

**Display History**

Entering the **Display History (D H)** command displays performance counters for each hour of the past 24 in reverse chronological order, beginning with the last full hour. A screen similar to Figure 56 will appear.

The Pause command works the same for Display History as it does for the other display commands. Simply enter **D H P** to see a report on the performance counters, one screen at a time.

**Figure 56**  
**Display History (D H) screen**

LEI E1 Interface History Performance Log						
1/03/99 8:37 PM						
Hour	Errored	Bursty	Unavailable	Loss Frame	Frame Slip	Error
Ending	Seconds	Seconds	Seconds	Seconds	Seconds	Count
20:00	139	0	129	139	23	162
19:00	0	0	0	0	0	0
18:00	0	0	0	0	0	0
17:00	0	0	0	0	0	0
16:00	0	0	0	0	0	0

As with all **Display** commands, the Pause command can be used to display a full screen of the history report at a time, by entering **D H P**.

**Clear Error**

Reset the error counter to zero by entering the Clear Error (C E) command. The error counter provides a convenient way to determine if the E1 link is performing without errors since it can be cleared and examined at any time.

## Testing

The **Test Carrier (T)** command allows tests to be run on the LEI, the E1 link, or the CPE device. The three tests are designed to provide the capability to isolate faulty conditions in any of these three sources. See Table 108 on [page 308](#) for additional information on these three test types. Enter the **T** command, and at the prompt, enter which of these three tests is to be initiated. The prompt is similar to Figure 57.

**Figure 57**  
**Test Carrier (T) screen**

```
Test 1: Local Loopback Test
Test 2: External Loopback Test
Test 3: Network Loopback Test
(1,2,3 or S to cancel):
```

Tests can be performed once, for one through 98 minutes, or continuously (selected by entering 99 minutes), until a **Stop Test** command is entered. Tests continue for the duration specified even if a failure occurs, and terminate at the end of the time period or when a **Stop Test** command is issued. Only **Stop Test** stops a test with a duration selection of 99; however, the **STOP** command terminates a test set to any duration from one to 99. After entering the test number, a prompt similar to Figure 58 appears.

**Figure 58**  
**Test parameters screen**

```
Enter Duration of Test (1-98 Mins, 0 = Once, 99 = Forever)
Test will interfere with traffic. Hit Q to quit or any Key to Continue
```

Before a test is run, be sure to verify that the card is disabled, as the tests interfere with calls currently in process.

During a test, if an invalid word is received, this is recorded by a failure peg counter. The peg counter has a limit of 65,000. At the end of the test, the Test Results message indicates how many failures, if any, occurred during the test.

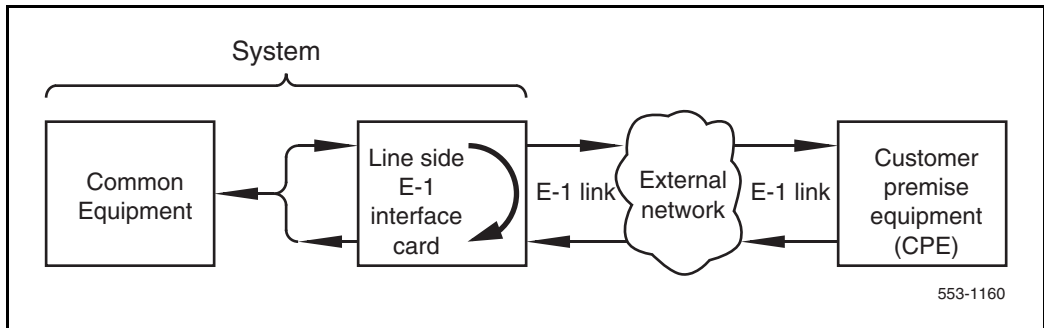
Table 108 shows which test to run for the associated equipment.

**Table 108**  
**MMI Tests**

Test number	Equipment Tested	Test Description
1	LEI	Local loopback
2	E1 link, LEI, and E1 network	External loopback
3	CPE device and E1 network	Network loopback

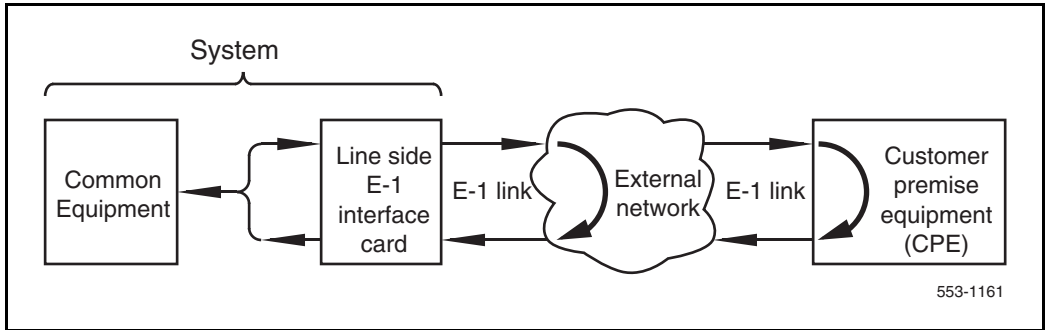
Test 1, local loopback, loops the E1 link signaling toward itself at the backplane connector. Test data is generated and received on all timeslots. If this test fails, it indicates that the LEI is defective. Figure 59 illustrates how the signaling is looped back toward itself.

**Figure 59**  
**MMI Local loopback test**



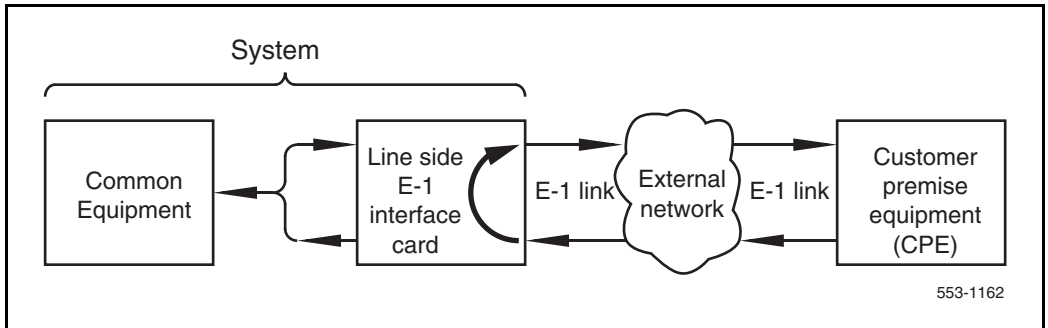
Test 2, external loopback, applies an external loopback to the E1 link. Test data is generated and received by the LEI on all timeslots. If test 1 passes but test 2 fails, it indicates that the E1 link is defective between the LEI and the external loopback location. If test 1 was not run and test 2 fails, the E1 link or the LEI could be defective. To isolate the failure to the E1 link, tests 1 and 2 must be run in tandem. Figure 60 on [page 309](#) demonstrates how an external loopback is applied to the E1 link.

**Figure 60**  
**MMI External loopback test**



Test 3, network loopback, loops the LEI's received E1 data back toward the CPE. No test data is generated or received by the LEI. If test 2 passes but test 3 fails, it indicates that the CPE device is defective. If test 2 was not run and test 3 fails, the E1 link or the CPE device could be defective. To isolate the failure to the CPE device, tests 2 and 3 must be run in tandem. Figure 61 illustrates how the signaling is looped back toward the CPE.

**Figure 61**  
**MMI Network loopback test**



## Applications

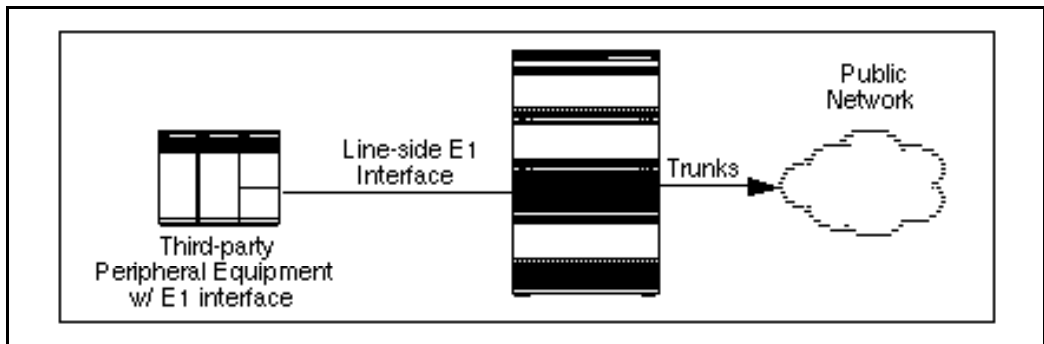
The LEI is an IPE line card that provides cost-effective connection between E1-compatible IPE and a CS 1000S, CS 1000M, and Meridian 1 system or off-premise extensions over long distances.

Some examples of applications where an LEI can be interfaced to an E1 link are:

- E1-compatible VRU equipment
- E1-compatible turret systems
- E1-compatible wireless systems
- Remote analog (500/2500-type) telephones through E1 to channel bank
- Remote Norstar sites behind CS 1000S, CS 1000M, and Meridian 1 over E1

The LEI is appropriate for any application where both E1 connectivity and “lineside” functionality are required. This includes connections to E1-compatible voice response units, voice messaging and trading turret (used in stock market applications) systems. See Figure 62.

**Figure 62**  
**LEI connection to IPE**

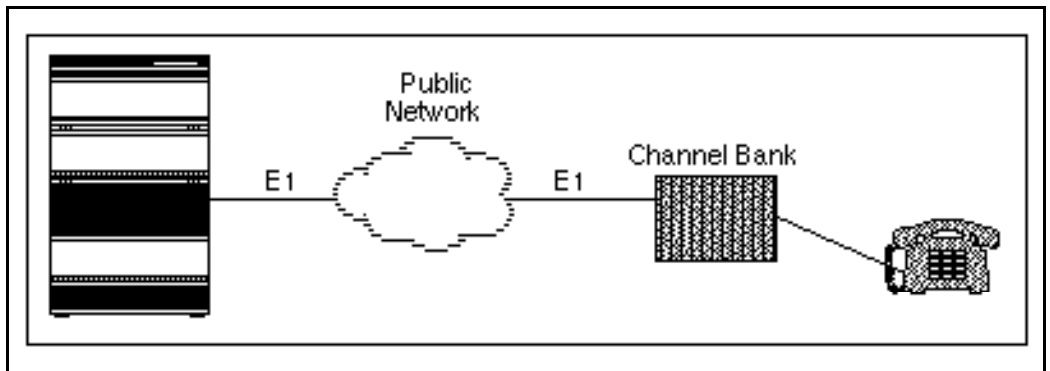


For example, the LEI can be used to connect the system to an E1-compatible Voice Response Unit (VRU). An example of this type of equipment is Nortel Open IVR system. In this way, the CS 1000S, CS 1000M, and Meridian 1 can

send a call to the VRU, and, because the LEI supports analog (500/2500-type) telephone functionality, the VRU is able to send the call back to the system for further handling.

The LEI can also be used to provide off-premise extensions to remote locations, up to 500 miles from the system. In this application, analog telephone functionality is extended over E1 facilities, providing a telephone at a remote site with access to analog (500/2500-type) telephone line functionality. See Figure 63. Audible Message Waiting Indicator can be provided as well.

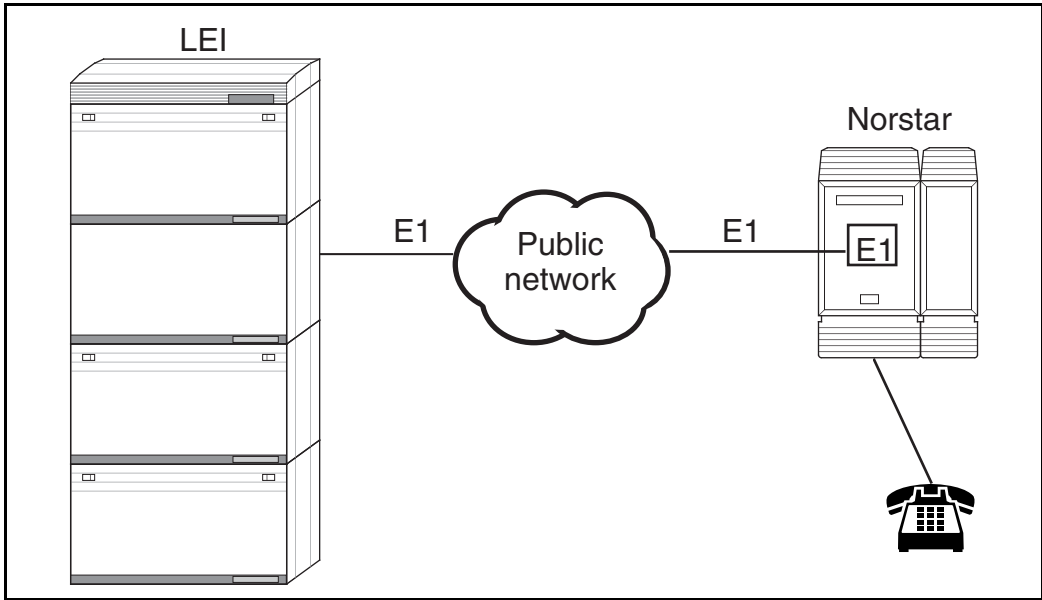
**Figure 63**  
**LEI in off-premise extension application**



Similarly, use the LEI to provide a connection between the system and a remote Norstar system. See Figure 64 on [page 312](#). In this case, channel banks are not required if the Norstar system is equipped with an E1 interface.

**Note:** Consider LEI audio levels when determining the appropriateness of an application.

**Figure 64**  
**LEI connection to Norstar system**





---

# NT5D60/80 CLASS Modem card (XCMC)

---

## Contents

This section contains information on the following topics:

Introduction . . . . .	313
Physical description . . . . .	313
Functional description . . . . .	314
Electrical specifications . . . . .	317
Configuration . . . . .	318

## Introduction

The NT5D60/80 CLASS Modem card supports the Custom Local Area Signaling Services (CLASS) feature. The CLASS Modem card receives Calling Number and Calling Name Delivery (CND) data and time/date data from the CS 1000S, CS 1000M, and Meridian 1 and transmits it to a line port, such as a port on an Analog Line card, which delivers the CND data to a CLASS telephone when presenting the telephone with a new call.

For information about the CLASS: Calling Number and Name Delivery feature, please refer to the *Features and Services* (553-3001-306). For administration and maintenance commands, see the *Software Input/Output: Administration* (553-3001-311).

## Physical description

CLASS Modem cards are housed in NT8D37 IPE modules.

The CLASS modem card circuitry is mounted on a 31.75 cm by 25.40 cm (12.5 in. by 10 in.) double-sided printed circuit board. The card connects to the backplane through a 160-pin edge connector.

The faceplate of the CLASS modem card is equipped with a red LED that lights when the card is disabled. When the card is installed, the LED remains lit for two to five seconds as a self-test runs. If the self-test completes successfully, the LED flashes three times and remains lit until the card is configured and enabled in software, then the LED goes out. If the LED continually flashes or remains weakly lit, replace the card.

## Functional description

The CLASS Modem card is designed to plug into any one of the peripheral card slots of the IPE module. The CLASS modem card supports up to 32 transmit-only modem resources, using a DS30X interface. Up to 255 modems can be configured per system.

The CND transmission process begins with the CS 1000 Release 4.5 software sending an initiating message to the CLASS Modem card indicating the length of the CND information and the type of the CND information flow to be transmitted. In response, the CLASS Modem card assigns a message buffer to capture the CND information from the CS 1000 Release 4.5 software.

System software then sends the CND information to the CLASS Modem card, one byte at a time, where it is stored in the message buffer. If the CLASS Modem card receives more bytes than were specified in the initiating message, then the additional bytes will be discarded and will not be included in the CND memory buffer.

Once all of the CND information has been stored in the memory buffer, the CLASS Modem card begins transmission when requested by the system software. Data is sent one ASCII character at a time. The CLASS Modem card inserts a start and stop bit to each ASCII character sent.

The transmission of the calling party name/number to the terminating telephone is accomplished through asynchronous FSK simplex-mode transmission at 1200 bits/second over a 2-wire loop, in accordance with the

Bell 202 standard. The transmission is implemented by the appropriate PCM equivalent of 1200 or 2200 Hz.

Upon completion of transmitting the CND data, the CLASS Modem card sends a message to the system software to indicate successful transmission of the CND data.

Eight modems can be associated with each module. Table 109 shows time slot mapping for the CLASS modem card.

**Table 109**  
**Time slot mapping (Part 1 of 2)**

XCMC mapping of TNs		Modem units on the CLASS Modem card
TNs	DS30X timeslot	
00	00	module 0, 00 01 02 03
01	01	
02	02	
03	03	
04	04	04 05 06 07
05	05	
06	06	
07	07	
08	08	module 1, 00 01 02 03
09	09	
10	10	
11	11	

**Table 109**  
**Time slot mapping (Part 2 of 2)**

XCMC mapping of TNs		Modem units on the CLASS Modem card
TNs	DS30X timeslot	
12	12	04
13	13	05
14	14	06
15	15	07
16	16	module 2, 00
17	17	01
18	18	02
19	19	03
20	20	04
21	21	05
22	22	06
23	23	07
24	24	module 3, 00
25	25	01
26	26	02
27	27	03
28	28	04
29	29	05
30	30	06
31	31	07

## Electrical specifications

This section lists the electrical characteristic of the CLASS modem card.

### Data transmission specifications

Table 110 provides specifications for the 32 transmit-only modem resources.

**Table 110**  
**CLASS modem card—data transmission electrical characteristics**

Characteristics	Description
Units per card	32 transmit only modem resources
Transmission rate	1200 ± 12 baud

The CLASS modem card has no direct connection to the Public Network.

### Power requirements

The CLASS modem card requires less than 1.0 Amps of +5V dc ± 1% supply supplied by the power converter in the IPE shelf.

### Environmental specifications

Table 111 shows the environmental specifications of the card.

**Table 111**  
**CLASS modem card – environmental specifications**

Parameter	Specifications
Operating temperature	0° C to +65° C (+32 ° F to +149 ° F)
Operating humidity	5 to 95% RH (non-condensing)
Storage temperature	–50° C to +70° C (–58 ° F to +158 ° F)

## Configuration

The NT5D60/80 CLASS Modem card has no user-configurable jumpers or switches. The card derives its address from its position in the backplane and reports that information back to the CS 1000S, CS 1000M, and Meridian 1 CPU through the Card LAN interface.

### Software service changes

On systems equipped with either CNUMB (package 332) or CNAME (package 333), up to 255 CLASS Modem (CMOD) units can be configured in LD 13, and analog (500/2500-type) telephones can be assigned as CLASS telephones in LD 10 by assigning them CNUS, or CNUA and CNA A class of service. See the *Software Input/Output: Administration* (553-3001-311) for LD 10 and LD 13 service change instructions.

---

# NT5D97 Dual-port DTI2/PRI2 card

---

## Contents

The following are the topics in this section:

<a href="#">Introduction</a> . . . . .	319
<a href="#">Physical description</a> . . . . .	320
<a href="#">Functional description</a> . . . . .	340
<a href="#">Architecture</a> . . . . .	353
<a href="#">Operation</a> . . . . .	359

## Introduction

This section contains information required to install the NT5D97 Dual-port DTI2/PRI2 (DDP2) card.

The NT5D97 is a dual-port 2.0 Mb DTI2/PRI2 card (the DDP2 firmware functions in DTI2 or PRI2 mode, depending on DIP switch settings) that integrates the functionality of two NT8D72BA PRI2 cards, and one QPC414 ENET card into a single CE card. The NT5D97 occupies a single slot in the Network shelf and provides two DTI2/PRI2 network connections: an interface to an external D-Channel Handler (the NT6D11AF) or the NT6D80 Multi-purpose Serial Data Link card, and an optional plug-on NTBK51AA Downloadable D-Channel daughterboard (DDCH) with two DCH interface ports.

The NT5D97 DDP2 card can be mixed in the same machine with PRI2 NT8D72BA cards.

The NT5D97 DDP2 card hardware design uses a B57 ASIC E1/T1 framer. The carrier specifications comply with the ANSI TL403 specification. The NT5D97 provides an interface to the 2.048 Mbps external digital line either directly or through an office repeater, Network Channel Terminating Equipment (NCTE), or Line Terminating Unit (LTU).



#### **DANGER OF ELECTRIC SHOCK**

The NT5D97 DDP2 card is not designed to be connected directly to the Public Switched Network, or other exposed plant networks. Such a connection should only be done using an isolating-type networking terminating device that provides voltage surge protection, such as a Line Terminating Unit (LTU), Network Channel Terminating Equipment (NCTE), or Network Termination 1 (NT1), as certified by your local, regional, or national safety agency and telecommunication authority.

## **Physical description**

### **External D-Channel Interface DCH or MSDL**

The connection between the DDP2 card and the external DCH or MSDL is through a 26-pin female D type connector. The data signals conform to the electrical characteristics of the EIA standard RS-422.

Two control signals are used to communicate the D-channel link status to the DCH or MSDL. These are:

- Receiver Ready (RR), originating at the DDP2 card, to indicate to the DCH or MSDL that the D-channel link is operational.
- Transmitter Ready (TR), originating at the DCH or MSDL, to indicate to the DDP2 card that the DCH are ready to use the D-channel link.



Table 112 indicates how the RR control signal operates with regard to the DDP2 status.

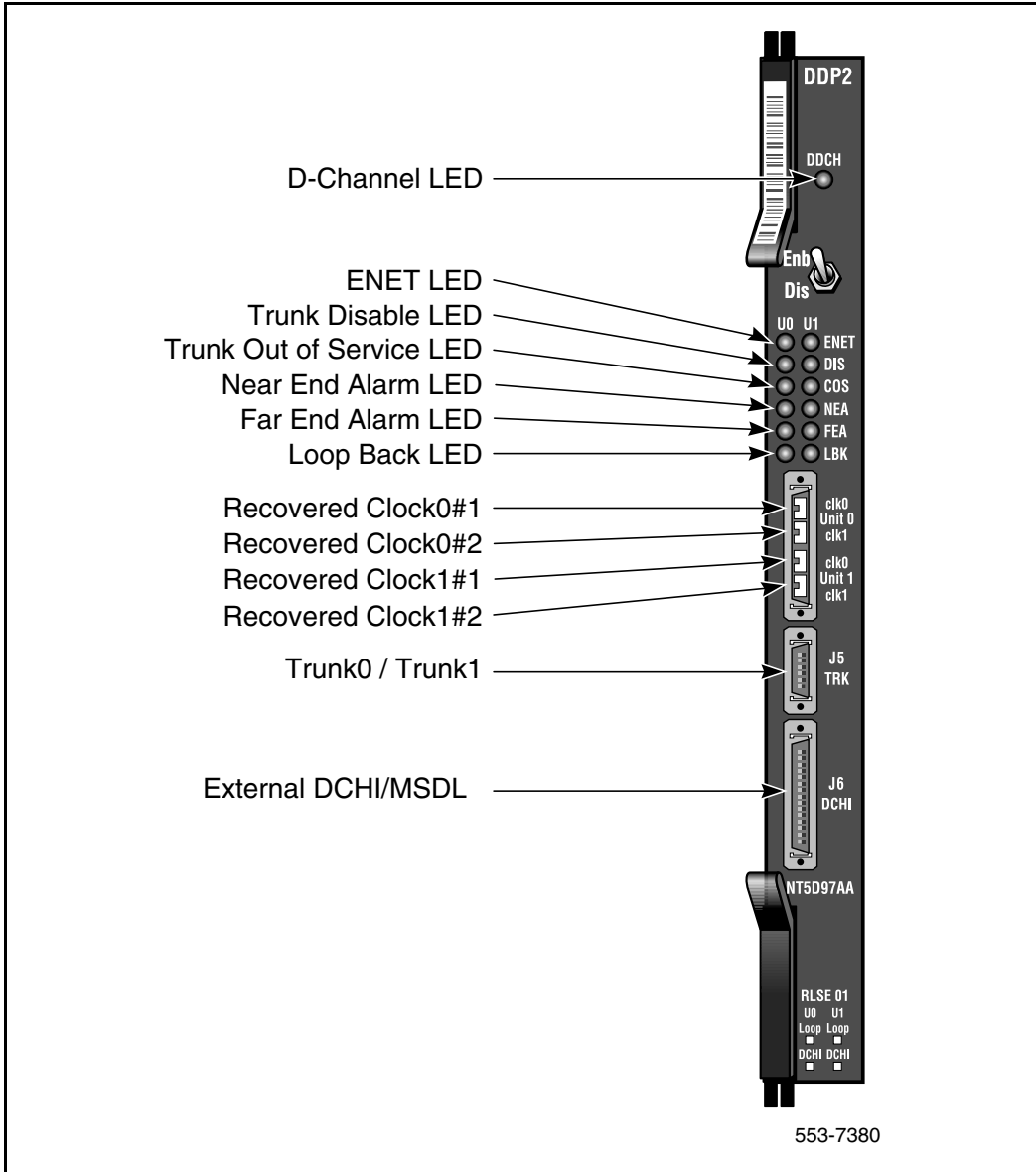
**Table 112**  
**DCH/MSDL Receiver Ready control signals**

RR State	Condition
ON	D-Channel data rate selected at 64 Kbps and PRI2 loop is enabled and PRI2 link is not in OOS or Local Alarm mode state and PRI2 link is not transmitting a Remote Alarm pattern and PRI2 link is not receiving a Remote Alarm Indication from a remote facility
OFF	All other conditions

## NT5D97 faceplate

Figure 65 on [page 322](#) illustrates the faceplate layout for the NT5D97 DDP card. The faceplate contains an enable/disable switch; a DDCH status LED; 6 x 2 trunk port status LEDs; and six external connectors. Table 113 on [page 323](#) shows the name of each connector, its designation with respect to the faceplate and the name and description of the card it is connected to. Also shown are the names of the LEDs.

Figure 65  
NT5D97 faceplate



**Table 113**  
**External connectors and LEDs**

Function	Faceplate Designator	Type	Description
Switch	ENB/DIS	Plastic, ESD protected	Card Enable/disable switch
Connectors	Unit 0 Clock 0	RJ11 Connector	Connects reference clock 0 to Clock Controller card 0
	Unit 0 Clock 1	RJ11 Connector	Connects reference clock 0 to Clock Controller card 1
	Unit 1 Clock 0	RJ11 Connector	Connects reference clock 1 to Clock Controller card 0
	Unit 1 Clock 1	RJ11 Connector	Connects reference clock 1 to Clock Controller card 1
	J5 TRK	9 Pin Female D Connector	Two external E1 Trunk 0 and Trunk 1
	J6 DCH	26 Pin Female D Connector	Connects to external DCH or MSDL
LEDs	ENET	2 Red LEDs	ENET 0 or ENET 1 is disabled
	DIS	2 Red LEDs	Trunk 0 or Trunk 1 is disabled
	OOS	2 Yellow LEDs	Trunk is out of service
	NEA	2 Yellow LEDs	Local (Near End) Alarm
	FEA	2 Yellow LEDs	Far End Alarm
	LBK	2 Yellow LEDs	Loop Back test being performed on Trunk 0 or Trunk 1
	DCH	Bicolor Red/Green LED	NTBK51AA status

The following sections provide a brief description of each element on the faceplate.

### **Enable/Disable Switch**

This switch is used to disable the card prior to insertion or removal from the network shelf. While this switch is in disable position, the card will not respond to the system CPU.

### **ENET LEDs**

Two red LEDs indicate if the “ENET0” and “ENET1” portions of the card are disabled. These LEDs are lit in the following cases:

- When the enable/disable switch is in disabled state (lit by hardware).
- After power-up, before the card is enabled.
- When the ENET port on the card is disabled by software.

### **Trunk Disable (DIS) LEDs**

Two red LEDs indicate if the “trunk port 0” or “trunk port 1” portions of the card are disabled. These LEDs are lit in the following cases:

- Upon reception of the “disable loop” message from the software.
- After power-up.

### **OOS LEDs**

Two yellow LEDs indicate if the “trunk port 0” and “trunk port 1” portions of the card are out of service.

### **NEA LEDs**

Two yellow LEDs indicate if the near end detects absence of incoming signal or loss of synchronization in “trunk port 0” or “trunk port 1” respectively. The near-end alarm causes a far-end alarm signal to be transmitted to the far end.

### **FEA LEDs**

Two yellow LEDs indicate if a far-end alarm has been reported by the far end (usually in response to a near-end alarm condition at the far end) on “trunk port 0” or “trunk port 1”.

**LBK LEDs**

Two yellow LEDs indicate if a remote loopback test is being performed on trunk port 0 or trunk port 1. The loopback indication is active when the digital trunk is in remote loopback mode. Normal call processing is inhibited during the remote loopback test.

**DCH LED**

When the dual colored LED is red, it indicates the on-board DDCH is present but disabled. When the dual colored LED is green, it indicates the on-board DDCH is present and enabled. If a DDCH is not configured on the DDP2 card, this lamp is not lit.

**Unit 0 Clk Connectors**

Two RJ11 connectors for connecting:

- Digital trunk unit 0 recovered clock to primary or secondary reference source on clock controller card 0.
- Digital trunk unit 0 recovered clock to primary or secondary reference source on clock controller card 1.

**Unit 1 Clk Connectors**

Two RJ11 connectors for connecting:

- Digital trunk unit 1 recovered clock to primary or secondary reference source on clock controller card 0.
- Digital trunk unit 1 recovered clock to primary or secondary reference source on clock controller card 1.

**Connector J5 (TRK)**

A 9 pin D-Type connector used to connect:

- Digital trunk unit 0 receive and transmit Tip / Ring pairs.
- Digital trunk unit 1 receive and transmit Tip / Ring pairs.

**Connector J6 (DCH)**

A 26 pin D-type connector is used to connect the DDP2 card to the external MSDL or D-channel handler.

## Port definitions

Since the NT5D97 card is dual-card, it equips two ports; these ports can be defined in the following combinations:

**Table 114**  
**NT5D97AA/AB loops configuration**

		Loop 0		
		not configured	DTI2	PRI2
Loop 1	not configured	V	V	V
	DTI2	V	V	V
	PRI2	V	V	V

**Table 115**  
**NT5D97AD loops configuration**

		Loop 0			
		not configured	DTI2	PRI2	DDCS
Loop 1	not configured	V	V	V	V
	DTI2	V	V	V	V
	PRI2	V	V	V	X
	DDCS	V	V	X	V

*Note:* Each loop DPNSS can be defined in Normal or Extended addressing mode.

## System capacity and performance

### Physical capacity

Each NT5D97 DDP2 card occupies one slot on the network shelf. Each card supports two digital trunk circuits and two network loops. The total number of DDP2 cards per system is limited by the number of network loops, physical capacity of the shelf, number of DTI2/PRI2 interfaces allowed by the software and the range of DCH addresses.

### D-Channel capacity

The software configuration for the NTB51AA DDCH is similar to the MSDL and only supports D-channel functionality.

The system has a total capacity of 16 addresses (Device Addresses or DNUM) that can be reserved for DCH card, MSDL card or DDCH card. One exception is DNUM 0 which is commonly assigned to the TTY terminal.

No two different D-Channel providers can share the same DNUM. Hence, the combined maximum number of DCH, MSDL and DDCH cards in the system is 16.

The DCH has one D-Channel unit, the DDCH has two D-Channel units, and the MSDL has a maximum of four units. Therefore, the total number of D-Channel is derived by the following formula:

$$\text{Total\_Num\_DCH-Units} = \text{Num\_DCH} \times 1 + \text{Num\_DDCH} \times 2 + \text{Num\_MSDL} \times 4$$

Therefore, Total\_Num\_DCH-Units in any given system is between 0-63.

### CPU capacity

Using a NT5D97 DDP2 card instead of DTI2/PRI2 cards does not increase the load on the CPU. The DDP2 replaces an ENET card and two DTI2/PRI2 cards. Emulating the ENET card and the overall CPU capacity is not impacted by using a DDP2 card instead of a DTI2/PRI2 card.

### Power requirements

Table 116 lists the power requirements for the NT5D97 DDP2 card.

**Table 116**  
**NT5D97 DDP2 power requirements**

Voltage	Source	Current	
		DDP2 (without NTBK51AA)	DDP2 (with NTBK51AA)
+5V	Backplane	3A	3.8A
+12V	Backplane	25mA	75mA
-12V	Backplane	25mA	75mA
Total Power (Maximum)		15.6W	20.8W

### Cable requirements

This section lists the types of cable used and the lengths required for internal and external NT5D97 DDP2 connections.

*Note:* No additional cabling is required for nB+D configurations. Multiple DDP2 cards and the D-channel are associated through software in LD 17.

DDP2 cable assemblies include:

- E1 carrier cables
  - NTCK45AA (A0407956)
  - NT8D7217 (A0617192)
  - NTCK78AA (A0618294)
  - NTCK79AA (A0618296)
- DDP2 to QPC471/QPC775 Clock Controller Cables
  - NTCG03AA



- NTCG03AB
- NTCG03AC
- NTCG03AD
- DDP2 to DCH cables
  - NTCK46AA
  - NTCK46AB
  - NTCK46AC
  - NTCK46AD
- DDP2 to MSDL cables
  - NTCK80AA
  - NTCK80AB
  - NTCK80AC
  - NTCK80AD

A description of each type of DDP2 cable follows.

### **E1 carrier cables**

#### ***NTCK45AA (A0407956)***

The NTCK45AA (8 ft.) is an 120 $\Omega$  cable for systems equipped with an I/O filter panel, connecting the TRK port (P1, D-type 9 pin male) on the DDP2 faceplate to the I/O filter (P2, P3 D-type 9 pin males).

**Figure 66**  
**NTCK45AA**

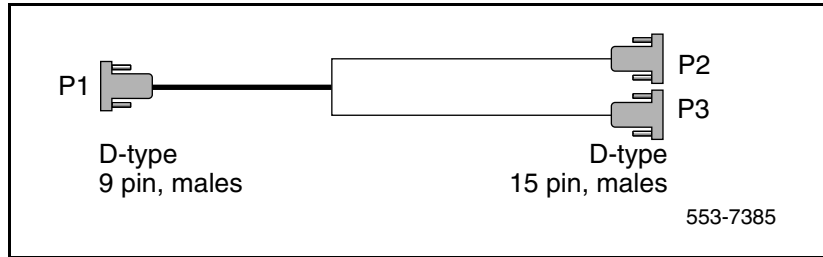


Table 117 which follows lists the pin attributes for the NTCK45AA cable.

**Table 117**  
**NTCK45AA cable pins (Part 1 of 2)**

Cable	Name	Description	Color	DDP2 pins	I/O Panel pins
0	T-PRI0TX	Trunk 0 Transmit Tip	Black	P1-1	P2-6
0	R-PRI0TX	Trunk 0 Transmit Ring	Red	P2-2	P2-7
0	T-PRI0RX	Trunk 0 Receive Tip	Black	P1-3	P2-2
0	R-PRI0RX	Trunk 0 Receive Ring	White	P1-4	P2-3
0		GND Shield Wire	Bare	N/C	Case P2
0		GND Shield Wire	Bare	N/C	Case P2
0		Standard Wire (3")	Bare	Case P2	P2-5
0		Standard Wire (3")	Bare	Case P2	P2-9
1	T-PRI1TX	Trunk 1 Transmit Tip	Black	P1-5	P3-6
1	R-PRI1TX	Trunk 1 Transmit Ring	Red	P1-6	P3-7
1	T-PRI1RX	Trunk 1 Receive Tip	Black	P1-7	P3-2
1	R-PRI1RX	Trunk 1 Receive Ring	White	P1-8	P3-3
1		GND Shield Wire	Bare	N/C	Case P3

**Table 117**  
**NTCK45AA cable pins (Part 2 of 2)**

Cable	Name	Description	Color	DDP2 pins	I/O Panel pins
1		GND Shield Wire	Bare	N/C	Case P3
1		Standard Wire (3")	Bare	Case P3	P3-5
1		Standard Wire (3")	Bare	Case P3	P3-9

**NT8D7217 (A0617192)**

The NT8D7217 (50 ft.) is an 120Ω cable for systems equipped with an I/O filter panel, connecting the 9 pin I/O filter connector to the 9 pin NCTE connector.

**Figure 67**  
**NT8D7217**

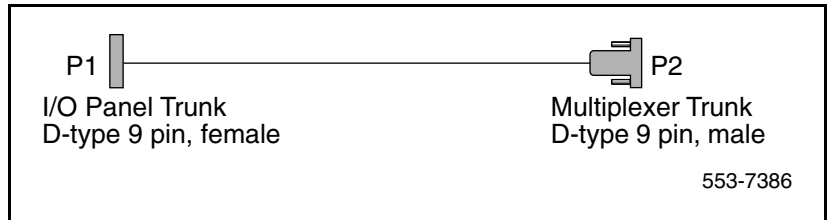


Table 118 which follows lists the pin attributes for the NT8D7217 cable.

**Table 118**  
**NT8D7217 cable pins (Part 1 of 2)**

Cable	Name	Description	Color	DDP2 pins	I/O Panel pins
0	T-PRI0TX	Trunk 0 Transmit Tip	Black	P1-6	P2-6
0	R-PRI0TX	Trunk 0 Transmit Ring	White	P1-7	P2-7
0	T-PRI0RX	Trunk 0 Receive Tip	Black	P1-2	P2-2
0	R-PRI0RX	Trunk 0 Receive Ring	Red	P1-3	P2-3

**Table 118**  
**NT8D7217 cable pins (Part 2 of 2)**

Cable	Name	Description	Color	DDP2 pins	I/O Panel pins
0		GND Shield Wire	Bare	P1-5	N/C
0		GND Shield Wire	Bare	P1-9	N/C
1	T-PRI1TX	Trunk 1 Transmit Tip	Black	P1-6	P2-6
1	R-PRI1TX	Trunk 1 Transmit Ring	White	P1-7	P2-7
1	T-PRI1RX	Trunk 1 Receive Tip	Black	P1-2	P2-2
1	R-PRI1RX	Trunk 1 Receive Ring	Red	P1-3	P2-3
1		GND Shield Wire	Bare	P1-5	N/C
1		GND Shield Wire	Bare	P1-9	N/C

**NTCK78AA (A0618294)**

The NTCK78AA (50 ft.) is an 120Ω cable for connecting the TRK port on the DDP2 faceplate (P1, D-type 9 pin male) to the Main Distribution Frame (MDF) (P2, P3 D-type 15 pin males). The NTCK78AA is used for systems not equipped with an I/O filter panel.

**Figure 68**  
**NTCK78AA**

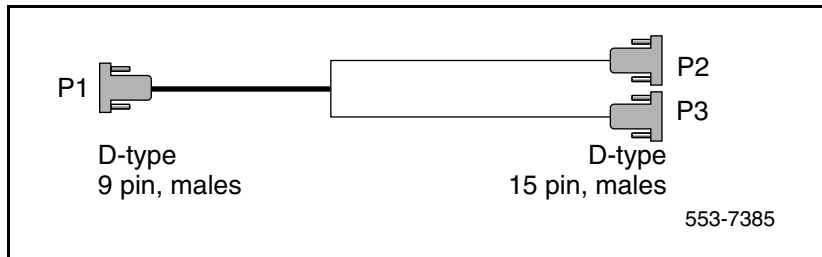


Table 119 lists the pin attributes for the NTCK78AA cable.

**Table 119**  
**NTCK78AA cable pins**

<b>Cable</b>	<b>Name</b>	<b>Description</b>	<b>Color</b>	<b>DDP2 pins</b>	<b>NCTE pins</b>
0	T-PRI0TX	Trunk 0 Transmit Tip	Black	P1-1	P2-1
0	R-PRI0TX	Trunk 0 Transmit Ring	Red	P1-2	P2-9
0	T-PRI0RX	Trunk 0 Receive Tip	Black	P1-3	P2-3
0	R-PRI0RX	Trunk 0 Receive Ring	White	P1-4	P2-11
0		GND Shield Wire	Bare	P1 Case	P2-2
0		GND Shield Wire	Bare	P1 Case	P2-4
1	T-PRI1TX	Trunk 1 Transmit Tip	Black	P1-5	P3-1
1	R-PRI1TX	Trunk 1 Transmit Ring	Red	P1-6	P3-9
1	T-PRI1RX	Trunk 1 Receive Tip	Black	P1-7	P3-3
1	R-PRI1RX	Trunk 1 Receive Ring	White	P1-8	P3-11
1		GND Shield Wire	Bare	P1 Case	P3-2
1		GND Shield Wire	Bare	P1 Case	P3-4

***NTCK79AA (A0618296)***

The NTCK79AA (40 ft) is a 75Ω coaxial cable for connecting the TRK port on the DDP2 faceplate (P1, D-type 9 pin male) to the Line Terminating Unit (LTU) (P2, P3, P4, P5 BNC males).

**Figure 69**  
**NTCK79AA**

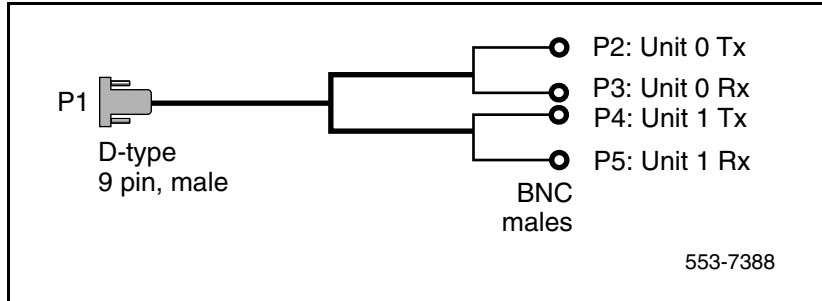


Table 120 lists the pin attributes for the NTCK79AA cable.

**Table 120**  
**NTCK79AA cable pins (Part 1 of 2)**

Cable	Name	Description	Color	DDP2 pins	NCTE pins
0	T-PRI0TX	Trunk 0 Transmit Tip	Red	P1-1	P2 inner conductor
0	R-PRI0TX	Trunk 0 Transmit Ring	Red	P1-2	P2 shield
0	T-PRI0RX	Trunk 0 Receive Tip	Green	P1-3	P3 inner conductor
0	R-PRI0RX	Trunk 0 Receive Ring	Green	P1-4	P3 shield
1	T-PRI1TX	Trunk 1 Transmit Tip	Red	P1-5	P4 inner conductor
1	R-PRI1TX	Trunk 1 Transmit Ring	Red	P1-6	P4 shield
1	T-PRI1RX	Trunk 1 Transmit Tip	Green	P1-7	P5 inner conductor
1	R-PRI1RX	Trunk 1 Receive Ring	Green	P1-8	P5 shield

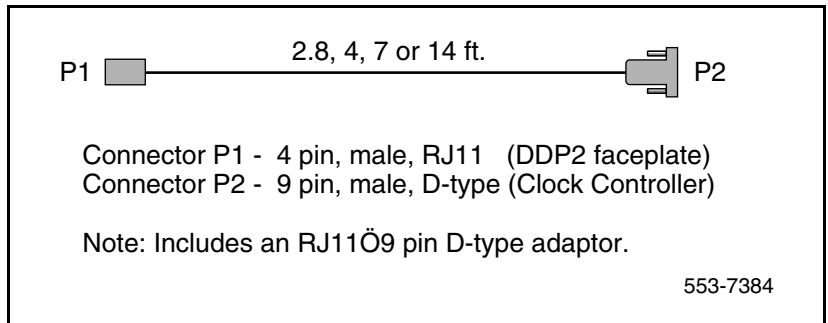
**Table 120**  
**NTCK79AA cable pins (Part 2 of 2)**

Cable	Name	Description	Color	DDP2 pins	NCTE pins
1		Outer metallized PVC shield	Bare	N/C	P1 Case
1		3 stranded wire	Bare	N/C	P1 Case

**Reference clock cables**

The NTCG03AA (14 ft), NTCG03AB (2.8 ft), NTCG03AC (4.0 ft), or NTCG03AD (7 ft), is a DDP2 card to Clock Controller cable, connecting each of the CLK0 or CLK1 ports on the DDP2 faceplate to the primary or secondary source ports on Clock Controller card 0 or 1.

**Figure 70**  
**NTCG03AA/AB/AC/AD**



**MSDL/DCH cables**

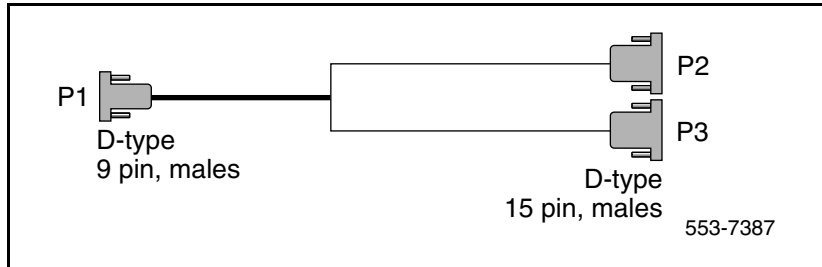
**External DCH cable**

The NTCK46 cable connects the DDP2 card to the NT6D11AF/NT5K75AA/NT5K35AA D-Channel Handler card. The cable is available in four different sizes:

- NTCK46AA (6 ft.) - DDP2 to DCH cable
- NTCK46AB (18 ft.) - DDP2 to DCH cable

- NTCK46AC (35 ft.) - DDP2 to DCH cable
- NTCK46AD (50 ft.) - DDP2 to DCH cable

**Figure 71**  
**NTCK46AA/AB/AC/AD**

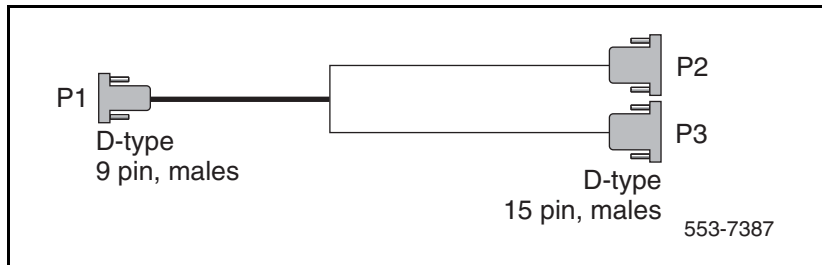


**External MSDL cable**

The NTCK80 cable connects the DDP2 card to the NT6D80 MSDL card. The cable is available in four different sizes:

- NTCK80AA (6 ft) - DDP2 to MSDL cable
- NTCK80AB (18 ft) - DDP2 to MSDL cable
- NTCK80AC (35 ft) - DDP2 to MSDL cable
- NTCK80AD (50 ft) - DDP2 to MSDL cable

**Figure 72**  
**NTCK80AA/AB/AC/AD**





## Cable diagrams

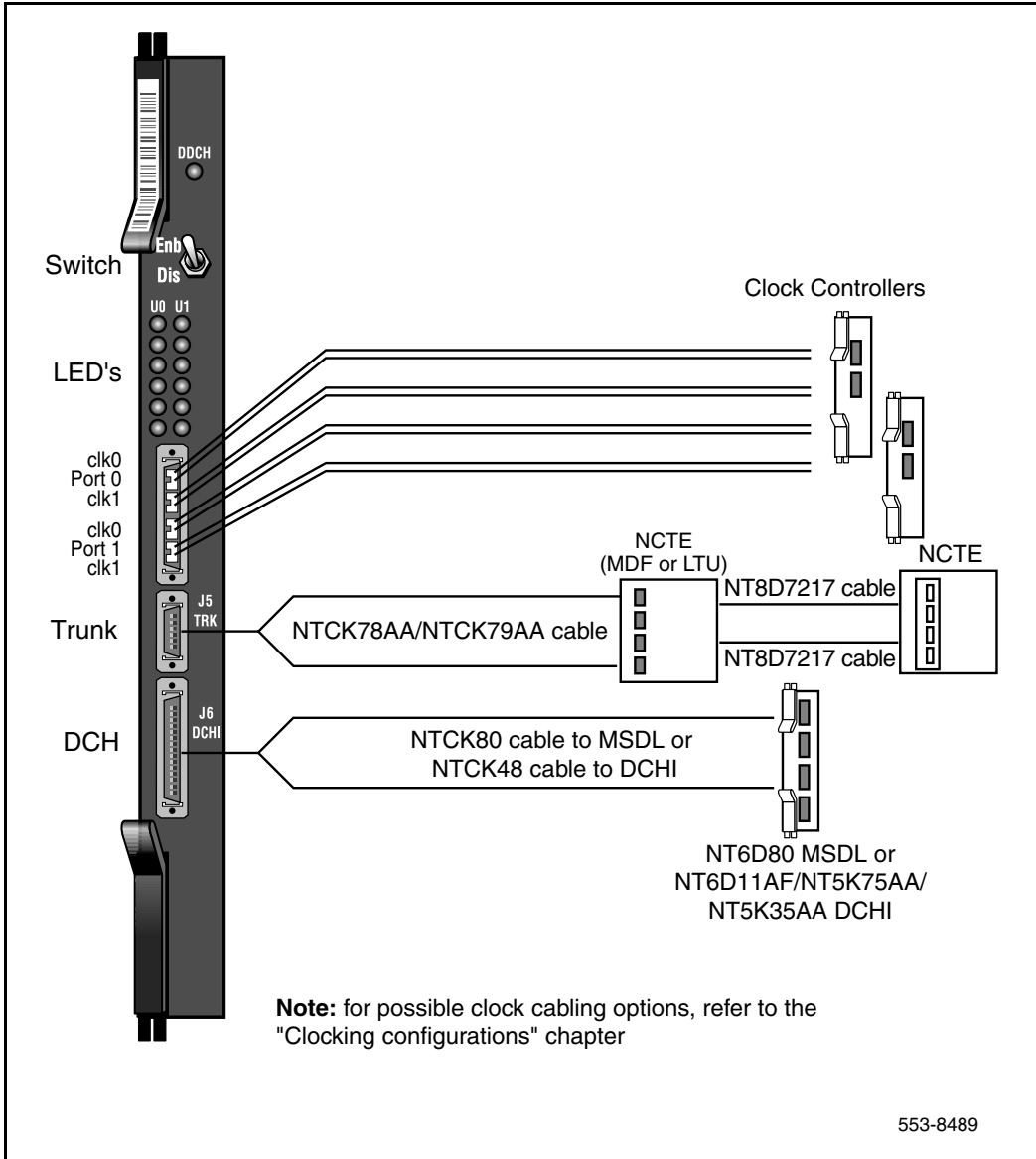
Figure 73 on [page 338](#) and Figure 74 on [page 339](#) provide examples of typical cabling configurations for the DDP2.

Figure 73 shows a typical DDP2 cabling for a system with an I/O panel, with the connection between the I/O panel and a Network Channel Terminating Equipment (NCTE).

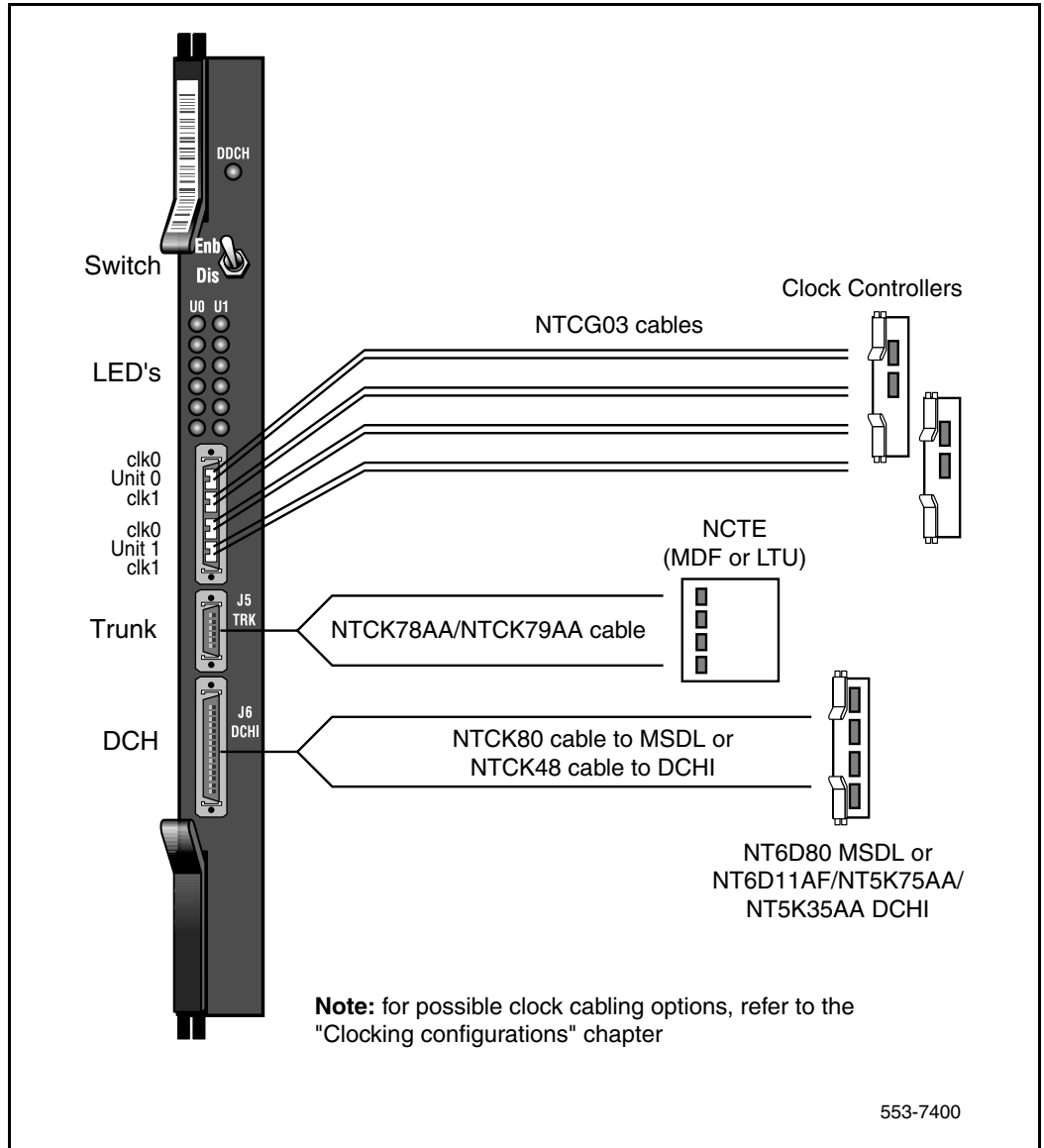
Figure 74 shows cabling for a system without an I/O panel. Here, the DDP2 faceplate is cabled directly to the NCTE.

**Note:** Since several clock cabling options exist, none has been represented in the diagrams. Refer to “Clock configurations” on [page 356](#) for a description on each available option.

**Figure 73**  
**DDP2 cable for systems with an I/O panel**



**Figure 74**  
**DDP2 cable for systems without an I/O panel**



## Functional description

### NT5D97 circuit card locations

Each NT5D97 card requires one slot on a shelf. NT5D97 cards can be placed in any card slot in the network bus.

**Note in all cases** - If an NT8D72BA/NTCK43 card is being replaced by a DDP2 card, the D-channel Handler can be reconnected to the DDP2 card, or removed if an onboard NTBK51DDCH card is used. Also, DIP Switches in the NT5D97 must be set properly before insertion. NT5D97 has a different DIP Switch setting from NTCK43AB. Refer to “NT5D97AA/AB DIP switch settings” on [page 340](#) for DIP switch setting).

### NT5D97AA/AB DIP switch settings

The NT5D97 DDP2 card is equipped with 6x2 sets of DIP switches for trunk parameters settings for port0 and port1 respectively. Additionally, the DDP2 card is equipped with one set of four DIP switches for the Ring Ground setting. The NT5D97AA/AB has one set of eight DIP switches and NT5D97AD has two sets of ten DIP switches for the D-channel Handler parameters setting.

The DIP switches are used for the setting of default values of certain parameters. Firmware reads the general purpose switches, which sets the default values accordingly.

**Table 121**  
**DIP switch settings for NT5D97AA/AB (Part 1 of 2)**

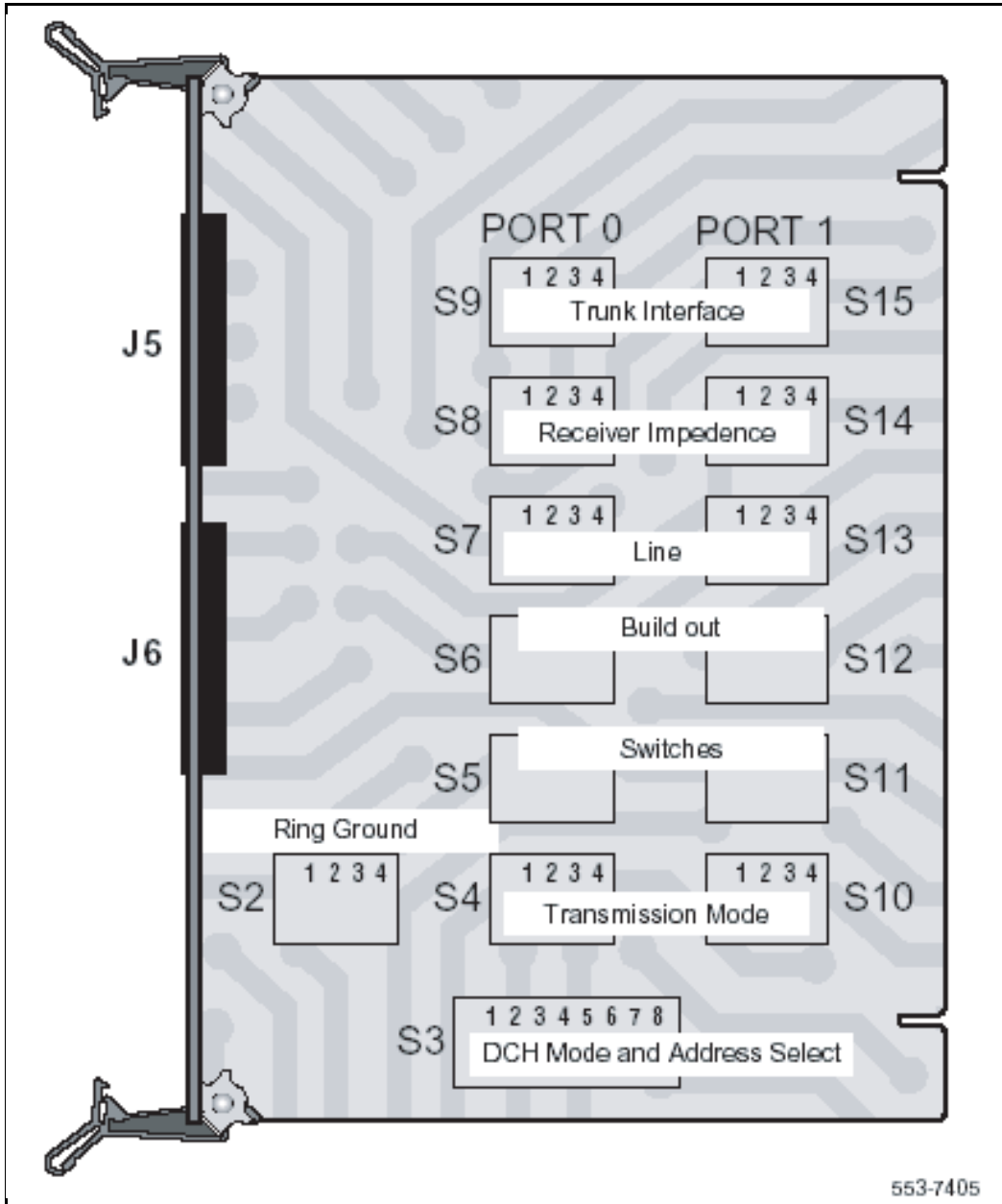
	Card	Trunks 0 and 1	Port 0	Port 1	Trunk 0	Trunk 1
ENB/DSB mounted on the face plate	S1					
Ring Ground		S2				
MSDL			S3			
TX Mode					S4	S10

**Table 121**  
**DIP switch settings for NT5D97AA/AB (Part 2 of 2)**

	<b>Card</b>	<b>Trunks 0 and 1</b>	<b>Port 0</b>	<b>Port 1</b>	<b>Trunk 0</b>	<b>Trunk 1</b>
LBO Setting					S5	S11
					S6	S12
					S7	S13
Receiver Interface					S8	S14
General Purpose					S9	S15

The following parameters are set by DIP switches. The boldface font shows the factory set-up.

Figure 75  
Dip switches for NT5D97AA/AB



## Trunk interface switches for NT5D97AA/AB

### Impedance level and unit mode

The S9/S15 switch selects the impedance level and loop operation mode on DEI2 OR PRI2. Refer to Table 122.

**Table 122**  
**Impedance level and loop mode switch settings**

Switch	Description	S9/S15 Switch Setting
1	Impedance level	OFF - 120 ohm ON - 75 ohm
2	Spare	X
3	Spare	X
4	Unit mode	OFF - Loop operates in the DTI2 mode ON - Loop operates in the PRI2 mode

### Transmission mode

A per-trunk switch (S4/S10) provides selection of the digital trunk interface type. Refer to Table 123.

**Table 123**  
**Impedance level and loop mode switch settings**

Description	S4/S10 switch settings
E1	OFF
Not used	

### Line build out

A per-trunk set of three switches (S5/S11, S6/S12 and S7/S13) provides the dB value for the line build out. Refer to Table 124 on [page 344](#).

*Note:* Do not change this setup.

**Table 124**  
**Trunk interface line build out switch settings**

Description	Switch setting		
	S5/S11	S6/S12	S7/S13
0dB	OFF	OFF	OFF

**Receiver impedance**

A per-trunk set of four DIP switches (S8/S14 provides selection between 75 or 120 ohm values. Refer to Table 125.

**Table 125**  
**Trunk interface impedance switch settings**

Description	S8/S14 switch setting			
75 ohm	OFF	OFF	ON	OFF
120 ohm	OFF	OFF	OFF	ON

**Ring ground switches for NT5D97AA/AB**

A set of four Dip switches (S2) selects which Ring lines are connected to ground. Refer to Table 126.

**Table 126**  
**Ring ground switch settings (Part 1 of 2)**

Switch	Description	S2 switch settings
1	Trunk 0 Transit	<b>OFF-Ring line is not grounded</b> ON- Ring line is grounded
2	Trunk 0 Receive	<b>OFF-Ring line is not grounded</b> ON- Ring line is grounded



**Table 126**  
**Ring ground switch settings (Part 2 of 2)**

Switch	Description	S2 switch settings
3	Trunk 1 Transmit	<b>OFF-Ring line is not grounded</b> ON- Ring line is grounded
4	Trunk 1 Receive	<b>OFF-Ring line is not grounded</b> ON- Ring line is grounded

**DCH Address select switch for NTB51AA daughter board for NT5D97AA/AB**

In case of an on-board NTB51AA D-channel daughterboard, set of four switches (S3) provide the daughterboard address. Refer to Table 134 on [page 350](#).

*Note:* Switch 8 of S3 (S3-8) does not require a switch setting to select between the on-board NTB51AA D-channel daughterboard and an external DCHI/MSDL. The NT5D97 detects when the on-board NTB51AA D-channel daughterboard is used.

**Table 127**  
**DCH mode and address switch settings**

Switch	Description	S3 switch setting
1-4	D-channel daughterboard address	See Table 128
5-8	For future use	OFF

Table 128 shows the possible selection of the NTB51AA D-channel.

**Table 128**  
**NTB51AA daughterboard address select switch settings (Part 1 of 2)**

Device Address	Switch Setting			
	0	OFF	OFF	OFF
1	ON	OFF	OFF	OFF

**Table 128**  
**NTBK51AA daughterboard address select switch settings (Part 2 of 2)**

Device Address	Switch Setting			
2	OFF	ON	OFF	OFF
3	ON	ON	OFF	OFF
4	OFF	OFF	ON	OFF
5	ON	OFF	ON	OFF
6	OFF	ON	ON	OFF
7	ON	ON	ON	OFF
8	OFF	OFF	OFF	ON
9	ON	OFF	OFF	ON
10	OFF	ON	OFF	ON
11	ON	ON	OFF	ON
12	OFF	OFF	ON	ON
13	ON	OFF	ON	ON
14	OFF	ON	ON	ON
15	ON	ON	ON	ON
<p><b>Note 1:</b> The system contains a maximum number of 16 DCHI, MSDL, and DDCH devices. The Device Addresses are equivalent to the MSDL DNUM designations.</p>				
<p><b>Note 2:</b> Device address 0 is commonly assigned to the System TTYD Monitor.</p>				

## NT5D97AD DIP switch settings

The the NT5D97 DDP2 card is equipped with 6x2 sets of DIP switches for trunk parameters settings for port0 and port1 respectively. Additionally, the DDP2 card is equipped with one set of four DIP switches for the Ring Ground setting. The NT5D97AA/AB has one set of eight DIP switches and NT5D97AD has two sets of ten DIP switches for the D-channel Handler parameters setting.

The DIP switches are used for the setting of default values of certain parameters. Firmware reads the general purpose switches, which sets the default values accordingly.

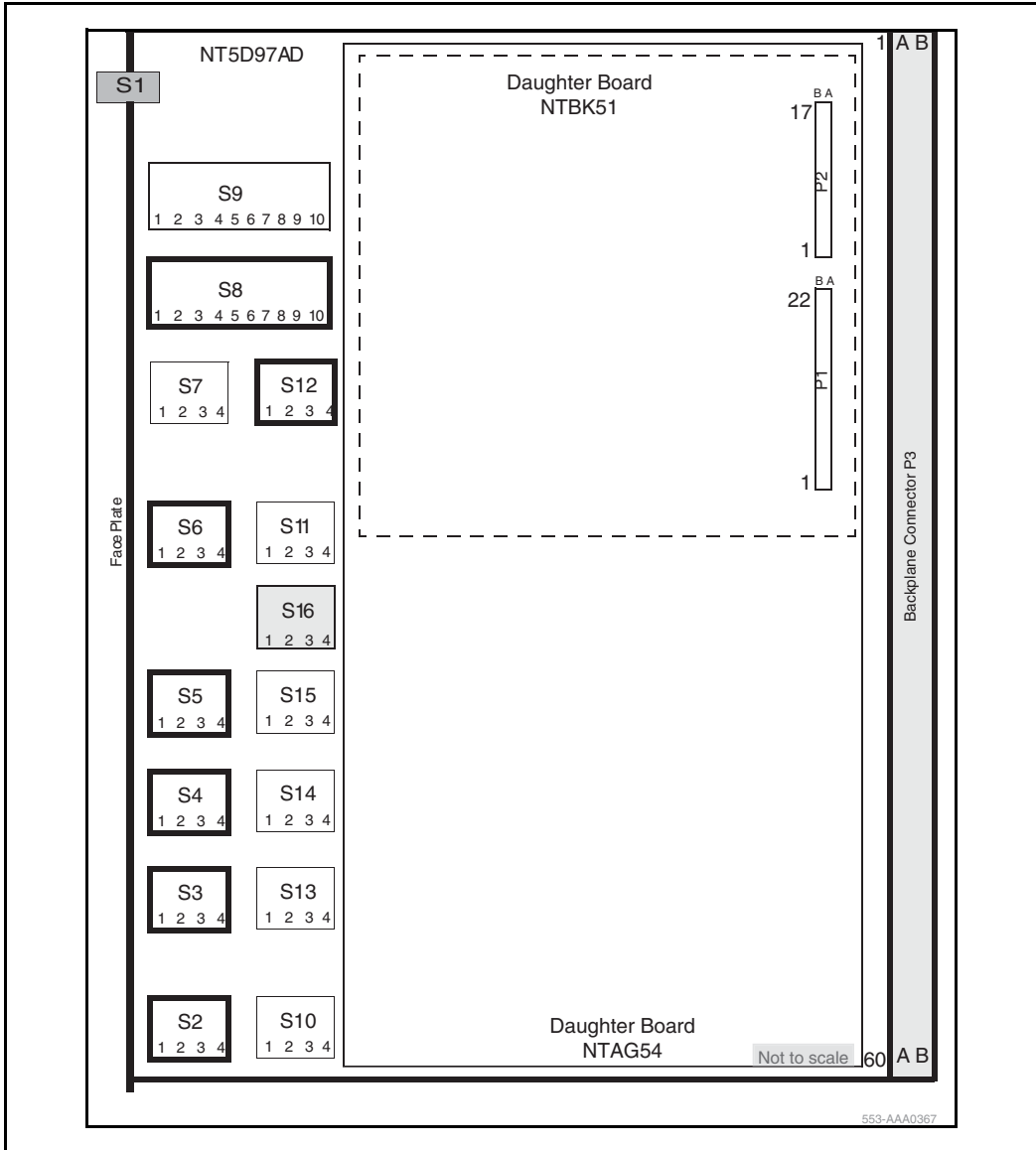
**Table 129**  
**DIP switch settings for NT5D97AD**

	<b>Card</b>	<b>Trunks 0 and 1</b>	<b>Port 0</b>	<b>Port 1</b>	<b>Trunk 0</b>	<b>Trunk 1</b>
ENB/DSB mounted on the face plate	S1					
Ring Ground		S16				
DPNSS			S8	S9		
MSDL			S9			
TX Mode					S2	S10
LBO Setting					S3	S13
					S4	S14
					S5	S15
Receiver Interface					S6	S11
General Purpose					S12	S7

Refer to DIP switch locations in Figure 76 on [page 348](#).

The following parameters are set by DIP switches. The boldface font shows the factory set-up.

**Figure 76**  
**Dip switches locations for NT5D97AD**



**Trunk interface switches for NT5D97AD**

***Trunk 0 switches***

Switch **S12** gives the MPU information about its environment.

**Table 130**  
**General purpose switches for NT5D97AD**

Switch	Description	S9/S15 Switch Setting
S12_1	Impedance level	<b>OFF - 120 ohm</b> ON - 75 ohm
S12_2	Spare	X
S12_3	Spare	X
S12_4	Unit mode	OFF - Unit operates in the DTI2 mode ON - Unit operates in the PRI2 mode

Switch **S2** selects the Transmission mode.

**Table 131**  
**TX mode switches for NT5D97AD**

TX mode	S2
E1	OFF
Not used	ON

Switch **S3**, **S4**, and **S5** select LBO function.

**Table 132**  
**LBO switches for NT5D97AD**

LBO setting	S3	S4	S5
<b>0dB</b>	<b>OFF</b>	<b>OFF</b>	<b>OFF</b>
7.5dB	ON	ON	OFF
15dB	ON	OFF	ON

Switch **S6** selects the Receiver interface.

**Table 133**  
Receiver interface switches for NT5D97AD

Impedance	S6-1	S6-2	S6-3	S6-4
75 ohm	OFF	OFF	ON	OFF
120 ohm	OFF	OFF	OFF	ON

**Trunk 1 switches for NT5D97AD**

**Table 134**  
Trunk 1 switches

Switch	Function
<b>S7</b>	<b>General Purpose...</b> See Table 130 on <a href="#">page 349</a>
<b>S10</b>	<b>TX Mode...</b> See Table 131 on <a href="#">page 349</a>
<b>S13, S14 &amp; S15</b>	<b>LBO...</b> See Table 132 on <a href="#">page 349</a>
<b>S11</b>	<b>RX Impedance...</b> See Table 133 on <a href="#">page 350</a>

**Ring ground switches for NT5D97AD**

Switch **S16** selects which ring lines connect to ground. When set to ON, the ring line is grounded.

**Table 135**  
Ring ground switch for NT5D97AD

Switch	Line
S16_1	Trunk 0 Transmit
S16_2	Trunk 0 Receive
S16_3	Trunk 1 Transmit
S16_4	Trunk 1 Receive

## DCH Address select switch for NTBK51AA daughterboard for NT5D97AD

Switch **S9** selects the NTBK51AA DCH daughter card address.

Switch **S8** is not used when the NTBK51AA daughter card is used. S8\_1-10 can be set to OFF position.

**Table 136**  
**NTBK51AA DCH switches for NT5D97AD**

Switch number	Function
S9_1-4	DCH daughter card address
S9_5-8	Set to OFF
S9_9	Set to ON (NTBK51AA Mode)
S9_10	Set to ON (NTBK51AA Mode)

## MSDL external card

**Table 137**  
Switch settings for MSDL external card

Switch number	Function
S9_1-10	X
S8_1-10	X

Use Table 138 to set the card address.

**Table 138**  
Switch setting for MSDL external card (Part 1 of 2)

DNUM (LD 17)	Switch Setting			
	1	2	3	4
0	OFF	OFF	OFF	OFF
1	ON	OFF	OFF	OFF
2	OFF	ON	OFF	OFF
3	ON	ON	OFF	OFF
4	OFF	OFF	ON	OFF
5	ON	OFF	ON	OFF
6	OFF	ON	ON	OFF
7	ON	ON	ON	OFF
8	OFF	OFF	OFF	ON
9	ON	OFF	OFF	ON
10	OFF	ON	OFF	ON
11	ON	ON	OFF	ON
12	OFF	OFF	ON	ON



**Table 138**  
**Switch setting for MSDL external card (Part 2 of 2)**

DNUM (LD 17)	Switch Setting			
	1	2	3	4
13	ON	OFF	ON	ON
14	OFF	ON	ON	ON
15	ON	ON	ON	ON

## Architecture

### Clock operation

There are two types of clock operation - tracking mode and free-run mode.

#### Tracking mode

In tracking mode, the DDP2 loop supplies an external clock reference to a clock controller. Two DDP2 loops can operate in tracking mode, with one defined as the primary reference source for clock synchronization, the other defined as the secondary reference source. The secondary reference acts as a back-up to the primary reference.

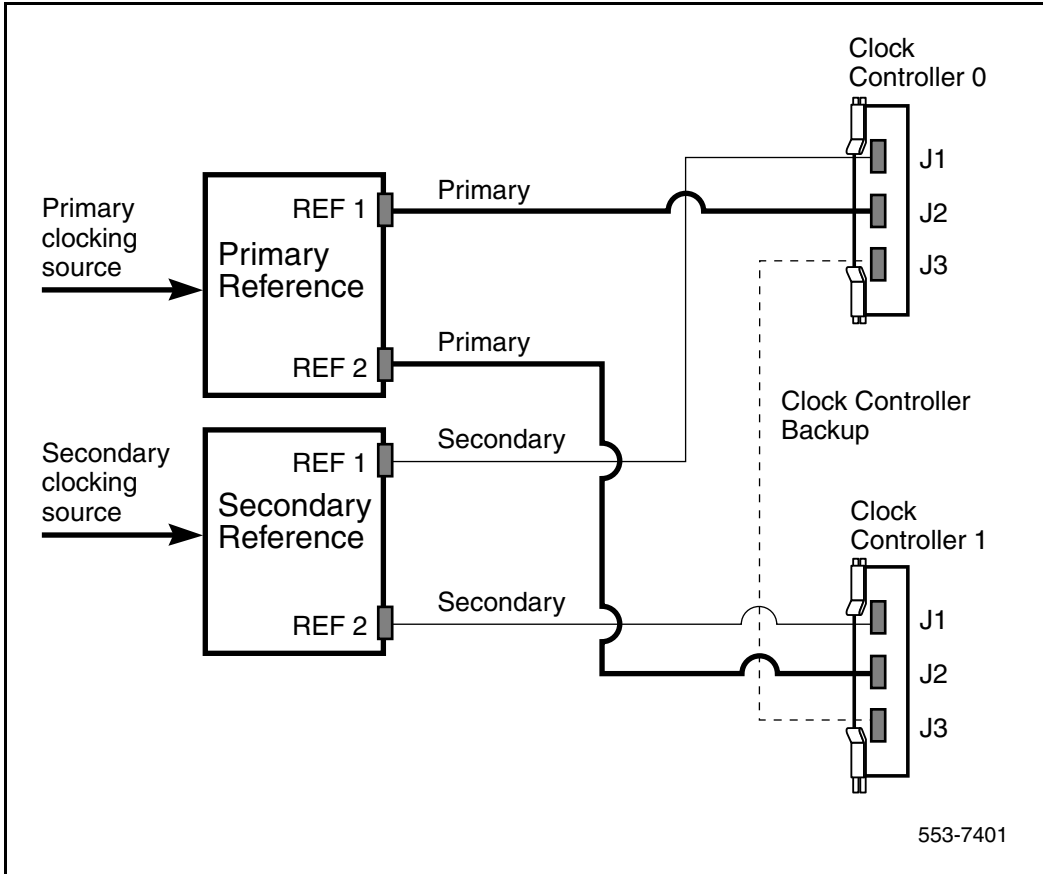
As shown in Figure 77, a system with dual CPUs can have two clock controllers (CC-0 and CC-1). One clock controller acts as a back-up to the other. The clock controllers should be completely locked to the reference clock.

#### Free run (non-tracking) mode

The clock synchronization of the can operate in free-run mode if:

- no loop is defined as the primary or secondary clock reference,
- the primary and secondary references are disabled, or
- the primary and secondary references are in local (near end) alarm

**Figure 77**  
**Clock Controller primary and secondary tracking**



### Reference clock errors

CS 1000 Release 4.5 software checks at intervals of 1 to 15 minutes to see if a clock controller or reference-clock error has occurred. (The interval of this check can be configured in LD 73).

In tracking mode, at any one time, there is one active clock controller which is tracking on one reference clock. If a clock controller error is detected, the

system switches to the back-up clock controller, without affecting which reference clock is being tracked.

A reference-clock error occurs when there is a problem with the clock driver or with the reference clock at the far end. If the clock controller detects a reference-clock error, the reference clocks are switched.

## Automatic clock recovery

A command for automatic clock recovery can be selected in LD 60 with the command EREF.

A DDP2 loop is disabled when it enters a local-alarm condition. If the local alarm is cleared, the loop is enabled automatically. When the loop is enabled, clock tracking is restored in the following conditions:

- If the loop is assigned as the primary reference clock but the clock controller is tracking on the secondary reference or in free-run mode, it is restored to tracking on primary.
- If the loop is assigned as the secondary reference clock but the clock controller is in free-run mode, it is restored to tracking on secondary.
- If the clock check indicates the switch is in free-run mode:
  - Tracking is restored to the primary reference clock if defined.
  - If the primary reference is disabled or in local alarm, tracking is restored to the secondary reference clock if defined.

**Note:** If the system is put into free-run mode by the craftsman, it resumes tracking on a reference clock unless the clock-switching option is disabled (LD 60, command MREF), or the reference clock is “undefined” in the database.

## Automatic clock switching

If the EREF command is selected in LD 60, tracking on the primary or secondary reference clock is automatically switched in the following manner:

- If software is unable to track on the assigned primary reference clock, it switches to the secondary reference clock and sends appropriate DTC maintenance messages.
- If software is unable to track on the assigned secondary reference clock, it switches to free run.

## Clock configurations

Clock Controllers can be used in a single or a dual CPU system.

A single CPU system has one Clock Controller card. This card can receive reference clocks from two sources referred to as the primary and secondary sources. These two sources can originate from a PRI2, DTI2, etc. PRI2 cards such as the NT8D72BA are capable of supplying two references of the same clock source. These are known as Ref1 (available at J1) and Ref2 (available at J2) on the NT8D72BA.

The NT5D97 card is capable of supplying two references from each clock source, for example, four references in total. NT5D97 can supply Clk0 and Clk1 from Unit 0 and Clk0 and Clk1 from Unit 1. Either Unit 0 or Unit 1 can originate primary source, as shown in Figure 78 through Figure 81.

There is one Clock Controller cable required for the DDP2 card, which is available in four sizes; this is the NTCG03AA/AB/AC/AD. Refer to “Reference clock cables” on [page 335](#) for more information.

Table 139 summarizes the clocking options. Table 140 on [page 358](#) explains the options in more detail.

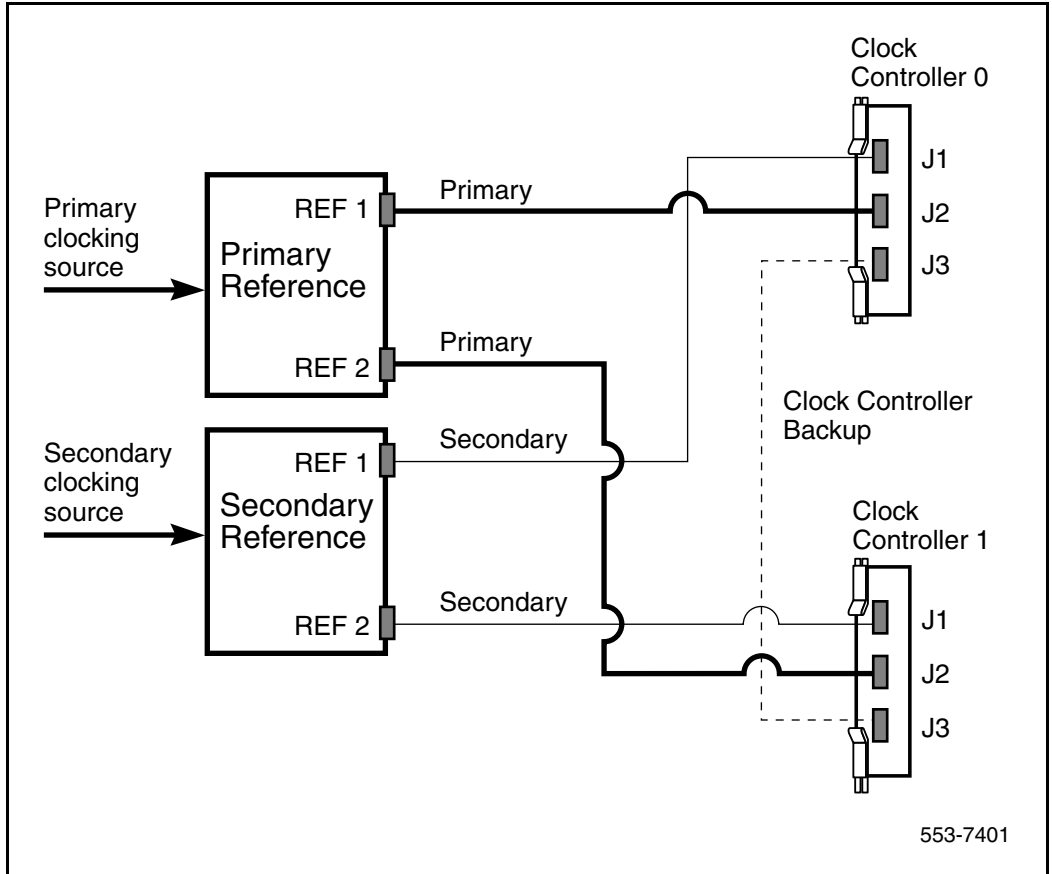
**Table 139**  
**Clock Controller options - summary**

CC Option	CPU Type	Notes
Option 1	Single	Ref from P0 on Clk0
		Ref from P1 on Clk0
Option 2	Dual	Ref from P0 on Clk0
		Ref from P0 on Clk1
Option 3	Dual	Ref from P1 on Clk0
		Ref from P1 on Clk1
Option 4	Dual	Ref from P0 on Clk0
		Ref from P0 on Clk1
		Ref from P1 on Clk0
		Ref from P1 on Clk1

**Table 140**  
**Clock Controller options - description**

<b>Clock Option</b>	<b>Notes</b>
Option 1	<p>This option provides a single CPU system with 2 clock sources derived from the 2 ports of the DDP2.</p> <p>Connector Clk0 provides a clock source from Unit 0.</p> <p>Connector Clk0 provides a clock source from Unit 1.</p> <p>Refer to Figure 78.</p>
Option 2	<p>This option provides a Dual CPU system with 2 references of a clock source derived from port 0 of the DDP2.</p> <p>Connector Clk0 provides a Ref 1 clock source from Unit 0.</p> <p>Connector Clk1 provides a Ref 2 clock source from Unit 0.</p> <p>Refer to Figure 79.</p>
Option 3	<p>This option provides a Dual CPU system with 2 references of a clock source derived from port 1 of the DDP2.</p> <p>Connector Clk0 provides a Ref 1 clock source from Unit 1.</p> <p>Connector Clk1 provides a Ref 2 clock source from Unit 1.</p> <p>Refer to Figure 80.</p>
Option 4	<p>This option provides a Dual CPU system with 2 references from each clock source derived from the DDP2.</p> <p>Connector Clk0 provides a Ref 1 clock source from Unit 0.</p> <p>Connector Clk1 provides a Ref 2 clock source from Unit 0.</p> <p>Connector Clk0 provides a Ref 1 clock source from Unit 1.</p> <p>Connector Clk1 provides a Ref 2 clock source from Unit 1.</p> <p>Refer to Figure 81.</p>

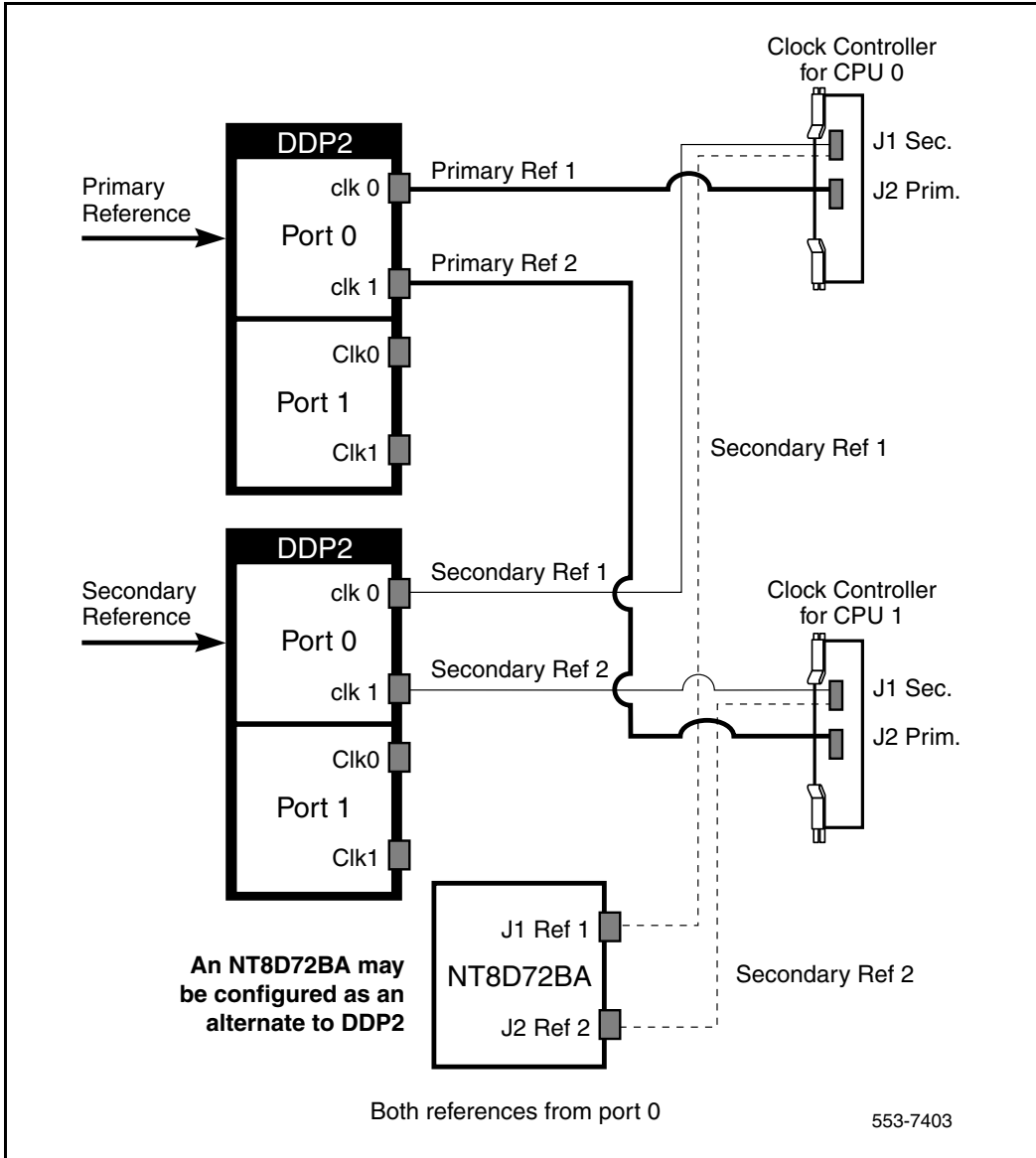
**Figure 78**  
**Clock Controller – Option 1**



## Operation

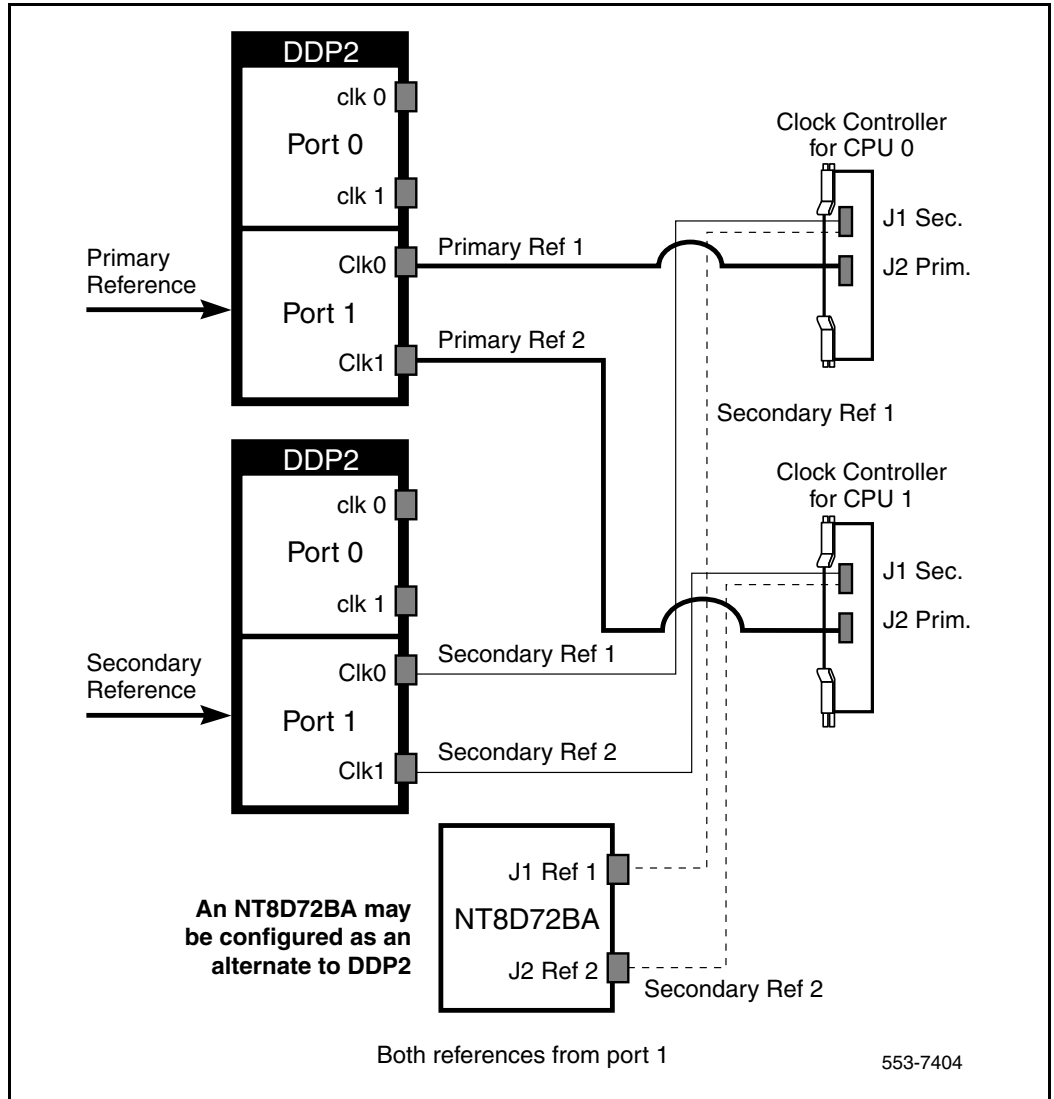
The following discussion describes possible scenarios when replacing a digital trunk NT8D72BA PRI2 card or QPC536E DTI2 card or NTCK43 Dual PRI card configuration with a NT5D97 DDP2 card configuration.

**Figure 79**  
**Clock Controller – Option 2**

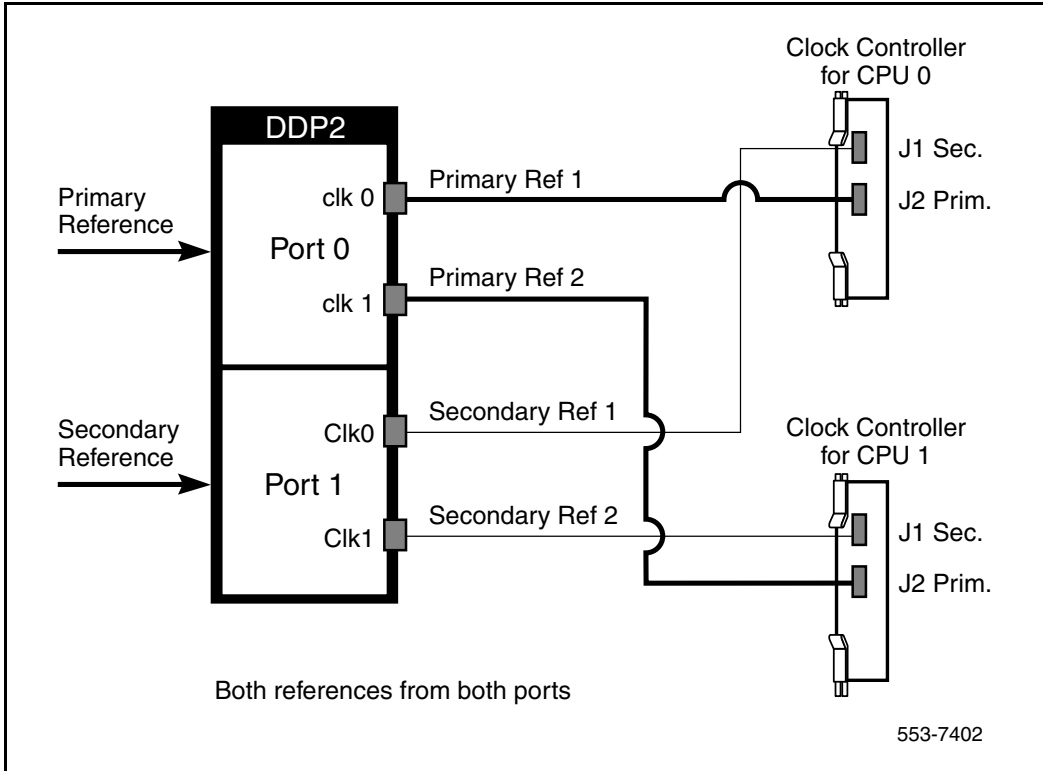




**Figure 80**  
**Clock Controller – Option 3**



**Figure 81**  
**Clock Controller – Option 4**



**Case 1** - The two ports of a QPC414 network card are connected to two digital trunks.

In this case, the QPC414 and the two digital trunks are replaced by a single DDP2 card, which is plugged into the network shelf in the QPC414 slot.

**Case 2** - One port of the QPC414 card is connected to a digital trunk, and the second is connected to a peripheral buffer. Both cards are in network loop location.

In this case, the QPC414 should not be removed. The digital trunk is removed and the DDP2 card is plugged into one of the two empty slots.

**Case 3** - The network shelf is full, one port of a QPC414 network card is connected to a digital trunk, and the second is connected to a peripheral buffer. This arrangement is repeated for another QPC414. The digital trunks are located in a shelf that provides only power.

In this case, the peripheral buffers will have to be re-assigned, so that each pair of buffers will use both ports of the same QPC414 card. The other QPC414 card can then be replaced by the NT5D97 DDP2.

**CAUTION**

The static discharge bracelet located inside the cabinet must be worn before handling circuit cards. Failure to wear the bracelet can result in damage to the circuit cards.

**Procedure 14**  
**Installing the NT5D97**

- 1 Determine the cabinet and shelf location where the NT5D97 is to be installed. The NT5D97 can be installed in any card slot in the Network bus.
- 2 Unpack and inspect the NT5D97 and cables.
- 3 If a DDCH is installed, refer to the section “Removing the NT5D97” on [page 364](#).
- 4 Set the option switches on the NT5D97 card before installation. Refer to “NT5D97AA/AB DIP switch settings” on [page 340](#).

The ENB/DIS (enable/disable faceplate switch) must be OFF (DIS) when installing the NT5D97, otherwise a system initialize can occur. The ENB/DIS on the NT5D97 corresponds to the faceplate switch on the QPC414 Network card.

- 5 Install NT5D97 card in the assigned shelf and slot.
- 6 Set the ENB/DIS faceplate switch to ON.  
If the DDCH is installed, the DDCH LED should flash three times.
- 7 If required, install the I/O adapters in the I/O panel.

- 8 Run and connect the NT5D97 cables.



**CAUTION**

Clock Controller cables connecting the Clock Controller and NT5D97 card must **NOT** be routed through the center of the cabinet past the power harness. Instead they should be routed around the outside of the equipment shelves.

- 9 If required, install connecting blocks at the MDF or wall mounted cross-connect terminal.
- 10 If required, designate connecting blocks at the MDF or wall mounted cross-connect terminal.
- 11 If required, install a Network Channel Terminating Equipment (NCTE), or Line Terminating Unit (LTU).
- 12 Add related office data into switch memory.
- 13 Enable faceplate switch S1. This is the “Loop Enable” switch.

The faceplate LEDs should go on for 4 seconds then go off and the OOS, DIS and ACT LEDs should go on again and stay on.

IF DDCH is installed, the DCH LED should flash 3 times.
- 14 Run the PRI/DTI Verification Test.
- 15 Run the PRI status check.

---

**End of Procedure**

---

**Procedure 15  
Removing the NT5D97**

- 1 Determine the cabinet and shelf location of the NT5D97 card to be removed.
- 2 Disable Network Loop using LD 60. The command is DISL “loop number.”

The associated DCHI might have to be disabled first. The faceplate switch ENB/DIS should not be disabled until both PRI2/DTI2 loops are disabled first.

- 3 If the NT5D97 card is being completely removed, not replaced, remove data from memory.
- 4 Remove cross connections at MDF to wall-mounted cross-connect terminal.
- 5 Tag and disconnect cables from card.
- 6 Rearrange Clock Controller cables if required.

**CAUTION**

Clock Controller cables connecting the Clock Controller and DDP2 card must **NOT** be routed through the center of the cabinet past the power harness. Instead, they should be routed around the outside of the equipment shelves.

- 7 Remove the DDP2 card only if both loops are disabled. If the other circuit of a DDP2 card is in use, **DO NOT** remove the card. The faceplate switch ENB/DIS must be in the OFF (DIS) position before the card is removed, otherwise the system will initialize.
- 8 Pack and store the NT5D97 card and circuit card.

---

**End of Procedure**

---

## Configuring the NT5D97

After the NT5D97 DDP2 is installed, configure the system using the same procedures as the standard NT8D72BA PRI2.

Consider the following when configuring the NT5D97 DDP2 card:

- The CS 1000 Release 4.5 software allows four ports to be defined for the NT6D80 MSDL. The DDCH (NTBK51AA) card has only two ports, 0 and 1; therefore, ports 2 and 3 must not be defined when using the NTBK51AA.

- Port 0 of the NTBK51AA can only be defined to work with Loop 0 of the NT5D97 DDP2 card, and Port 1 of the NTBK51AA can only be defined to work with Loop 1 of the NT5D97. This relationship must be reflected when configuring a new DCH in LD 17 (in response to the DCHL prompt, enter either 0 or 1 when specifying the loop number used by the DCH).
- You cannot define one of the DDP2 loops for the NTBK51AA DDCH, and the other loop for the NT6D11AF/NT5K75AA/NT5K35AA DCH card or the NT6D80 MSDL.
- When configuring the NT5D97 DDP2 in DTI2 outgoing dial pulse mode, a Digit Outpulsing patch is required.

## Testability and diagnostics

The DDP2 card supports testing and maintenance functions through the following procedures:

- Selftest upon power up or reset
- Signalling test performed in the LD 30
- Loopback tests, self tests, and continuity tests performed by LD 60 and LD 45
- The D-Channel (DCH, MSDL, DDCH) maintenance is supported by LD 96.

**Note:** The MSDL selftest is not applicable to the NTBK51AA D-Channel daughterboard.

---

# NT5K02 Flexible Analog Line card

---

## Contents

This section contains information on the following topics:

<a href="#">Introduction</a> .....	367
<a href="#">Applications</a> .....	368

## Introduction

The NT5K02 Flexible Analog Line card provides an interface for up to 16 analog (500/2500-type) telephones equipped with either ground button recall switches, high-voltage Message Waiting lamps, or low-voltage Message Waiting LEDs.

You can install this card in any IPE slot.

**Note:** Up to four NT5K02 Flexible Analog Line card are supported in each Media Gateway 1000S (MG 1000S). Up to four NT5K02 Flexible Analog Line card are supported in each MG 1000S Expansion.

The NT5K02 Flexible Analog Line card performs several functions, including:

- flexible transmission
- ground button operation
- low-voltage Message Waiting option
- card self-ID for auto-configuration

## Applications

The NT5K02 Flexible Analog Line card can be used for the following applications:

- NT5K02AA high-voltage Message Waiting analog line card typically used in Australia
- NT5K02DA ground button, low-voltage Message Waiting, analog line card typically used in France
- NT5K02EA ground button, low-voltage Message Waiting, analog line card typically used in Germany
- NT5K02FA ground button, low-voltage Message Waiting, analog line card with 600 $\Omega$  termination (A/D  $-4$  dB, D/A  $-1$  dB)
- NT5K02GA same as NT5K02FA with a different loss plan (A/D  $-4$  dB, D/A  $-3$  dB)
- NT5K02HA ground button, low-voltage Message Waiting, analog line card typically used in Belgium
- NT5K02JA low-voltage Message Waiting, analog line card typically used in Denmark
- NT5K02KA ground button, low-voltage Message Waiting, analog line card typically used in Netherlands
- NT5K02LA and NT5K02LB analog line card typically used in New Zealand
- NT5K02MA ground button, low-voltage Message Waiting, analog line card typically used in Norway
- NT5K02NA ground button, low-voltage message Waiting, analog line card typically used in Sweden
- NT5K02PA ground button, low-voltage Message Waiting, analog line card typically used in Switzerland
- NT5K02QA ground button, low-voltage Message Waiting, analog line card typically used in the United Kingdom



---

# NT5K21 XMFC/MFE card

---

## Contents

This section contains information on the following topics:

<a href="#">Introduction</a> . . . . .	369
<a href="#">MFC signaling</a> . . . . .	369
<a href="#">MFE signaling</a> . . . . .	372
<a href="#">Sender and receiver mode</a> . . . . .	373
<a href="#">Physical specifications</a> . . . . .	376

## Introduction

The XMFC/MFE (Extended Multi-frequency Compelled/Multi-frequency sender-receiver) card is used to set up calls between two trunks. Connections may be between a PBX and a Central Office or between two PBXs. When connection has been established, the XMFC/MFE card sends and receives pairs of frequencies and then drops out of the call.

The XMFC/MFE card can operate in systems using either A-law or  $\mu$ -law companding by changing the setting in software.

You can install this card in any IPE slot.

## MFC signaling

The MFC feature allows the system to use the CCITT MFC R2 or L1 signaling protocols.

## Signaling levels

MFC signaling uses pairs of frequencies to represent digits, and is divided into two levels:

- **Level 1:** used when a call is first established and may be used to send the dialed digits.
- **Level 2:** used after Level 1 signaling is completed and may contain such information as the status, capabilities, or classifications of both calling parties.

## Forward and backward signals

When one NT5K21 XMFC/MFE card sends a pair of frequencies to a receiving XMFC/MFE card (forward signaling), the receiving XMFC/MFE card must respond by sending a different set of frequencies back to the originating XMFC/MFE card (backward signaling). In other words, the receiving card is always “compelled” to respond to the originating card.

In summary, the signaling works as follows:

- The first XMFC/MFE card sends a forward signal to the second card.
- The second card hears the forward signal and replies with a backward signal.
- The first card hears the backward signal and “turns off” its forward signal.
- The second card hears the forward signal being removed and removes its backward signal.
- The first XMFC/MFE can either send a second signal or drop out of the call.

MFC signaling involves two or more levels of forward signals and two or more levels of backward signals. Separate sets of frequencies are used for forward and backward signals:

- **Forward signals.** Level I forward signals are dialed address digits that identify the called party. Subsequent levels of forward signals describe the category (Class of Service) of the calling party, and may include the calling party status and identity.
- **Backward signals.** Level I backward signals (designated “A”) respond to Level I forward signals. Subsequent levels of backward signals (B, C, and so on) describe the status of the called party.

Table 141 lists the frequency values used for forward and backward signals.

**Table 141**  
**MFC Frequency values (Part 1 of 2)**

Digit	Forward direction DOD-Tx, DID-Rx	backward direction DOD-Rx, DID-Tx
1	1380 Hz + 1500 Hz	1140 Hz + 1020 Hz
2	1380 Hz + 1620 Hz	1140 Hz + 900 Hz
3	1500 Hz + 1620 Hz	1020 Hz + 900 Hz
4	1380 Hz + 1740 Hz	1140 Hz + 780 Hz
5	1500 Hz + 1740 Hz	1020 Hz + 780 Hz
6	1620 Hz + 1740 Hz	900 Hz + 780 Hz
7	1380 Hz + 1860 Hz	1140 Hz + 660 Hz
8	1500 Hz + 1860 Hz	1020 Hz + 660 Hz
9	1620 Hz + 1860 Hz	900 Hz + 660 Hz
10	1740 Hz + 1860 Hz	780 Hz + 660 Hz
11	1380 Hz + 1980 Hz	1140 Hz + 540 Hz
12	1500 Hz + 1980 Hz	1020 Hz + 540 Hz
13	1620 Hz + 1980 Hz	900 Hz + 540 Hz

**Table 141**  
**MFC Frequency values (Part 2 of 2)**

<b>Digit</b>	<b>Forward direction DOD-Tx, DID-Rx</b>	<b>backward direction DOD-Rx, DID-Tx</b>
14	1740 Hz + 1980 Hz	780 Hz + 540 Hz
15	1860 Hz + 1980 Hz	660 Hz + 540 Hz

The exact meaning of each MFC signal number (1-15) within each level can be programmed separately for each trunk route using MFC. This programming can be done by the customer and allows users to suit the needs of each MFC-equipped trunk route.

Each MFC-equipped trunk route is associated with a data block that contains the MFC signal functions supported for that route.

## MFE signaling

The NT5K21 XMFC/MFE card can be programmed for MFE signaling which is used mainly in France. MFE is much the same as MFC except it has its own set of forward and backward signals.

Table 142 lists the forward and backward frequencies for MFE. The one backward signal for MFE is referred to as the “control” frequency.

**Table 142**  
**MFE Frequency values (Part 1 of 2)**

<b>Digit</b>	<b>Forward direction OG-Tx, IC-Rx</b>	<b>Backward direction</b>
1	700 Hz + 900 Hz	1900 Hz (Control Frequency)
2	700 Hz + 1100 Hz	—
3	900 Hz + 1100 Hz	—
4	700 Hz + 1300 Hz	—

**Table 142**  
**MFE Frequency values (Part 2 of 2)**

Digit	Forward direction OG-Tx, IC-Rx	Backward direction
5	900 Hz + 1300 Hz	—
6	1100 Hz + 1300 Hz	—
7	700 Hz + 1500 Hz	—
8	900 Hz + 1500 Hz	—
9	1100 Hz + 1500 Hz	—
10	1300 Hz + 1500 Hz	—

## Sender and receiver mode

The XMFC/MFE circuit card provides the interface between the system's CPU and the trunk circuit which uses MFC or MFE signaling.

The XMFC/MFE circuit card transmits and receives forward and backward signals simultaneously on two channels. Each channel is programmed like a peripheral circuit card unit, with its own sending and receiving timeslots in the network.

### Receive mode

When in receive mode, the XMFC/MFE card is linked to the trunk card by a PCM speech path over the network cards. MFC signals coming in over the trunks are relayed to the XMFC/MFE card as though they were speech. The XMFC/MFC card interprets each tone pair and sends the information to the CPU through the CPU bus.

### Send mode

When in send mode, the CPU sends data to the XMFC/MFE card through the CPU bus. The CPU tells the XMFC/MFE card which tone pairs to send and the XMFC/MFE card generates the required tones and sends them to the trunk over the PCM network speech path. The trunk transmits the tones to the far end.

## XMFC sender and receiver specifications

Table 143 and Table 144 provide the operating requirements for the NT5K21 XMFC/MFE card. These specifications conform to CCITT R2 recommendations: Q.441, Q.442, Q.451, Q.454, and Q.455.

**Table 143**  
**XMFC sender specifications**

Forward frequencies in DOD mode:	1380, 1500, 1620, 1740, 1860, 1980 Hz
Backward frequencies in DOD mode:	1140, 1020, 900, 780, 660, 540 Hz
Frequency tolerance:	+/- 0.5 Hz from nominal
Power level at each frequency:	Selectable: 1 of 16 levels
Level difference between frequencies:	< 0.5 dB
Harmonic Distortion and Intermodulation	37 dB below level of 1 signaling frequency
Time interval between start of 2 tones:	125 usec.
Time interval between stop of 2 tones:	125 usec.

**Table 144**  
**XMFC receiver specifications (Part 1 of 2)**

<b>Input sensitivity:</b>	
accepted:	-5 to -31.5 dBmONew CCITT spec.
rejected:	-38.5 dBmOBlue Book
<b>Bandwidth twist:</b>	
accepted:	fc +/- 10 Hz
rejected:	fc +/- 60 Hz
<b>Amplitude twist:</b>	
accepted:	difference of 5 dB between adjacent frequencies difference of 7 dB between non-adjacent frequencies
Norwegian requirement	difference of 12 dB (for unloaded CO trunks)
rejected:	difference of 20 dB between any two frequencies
Operating time:	< 32 msec.
Release time:	< 32 msec.

**Table 144**  
**XMFC receiver specifications (Part 2 of 2)**

Tone Interrupt no release:	< 8 msec. Receiver on, while tone missing
Longest Input tone ignored:	< 8 msec. Combination of valid frequencies
Noise rejection:	S/N > 18 dB No degradation, in band white noise S/N > 13 dB Out-of-band disturbances for CCITT

### **XMFE sender and receiver specifications**

Tables 145 and Table 146 on [page 376](#) provide the operating requirements for the XMFC/MFE card when it is configured as an XMFE card. These requirements conform to French Socotel specifications ST/PAA/CLC/CER/692.

**Table 145**  
**XMFE sender specifications**

Forward frequencies in OG mode:	700, 900, 1100, 1300, 1500 Hz
Forward frequencies in IC mode:	1900 Hz
Frequency tolerance:	+/- 0.25% from nominal
Power level at each frequency:	Selectable: 1 of 16 levels
Level tolerance:	+/- 1.0 dB
Harmonic Distortion and Intermodulation:	35 dB below level of 1 signaling frequency
Time interval between start of 2 tones:	125 usec.
Time interval between stop of 2 tones:	125 usec.

**Table 146**  
**XMFE receiver specifications**

<b>Input sensitivity:</b> accepted: rejected: rejected: rejected:	-4 dBm to -35 dBm +/- 10 Hz of nominal -42 dBm signals -4 dBm outside 500-1900 Hz -40 dBm single/multiple sine wave in 500-1900 Hz
<b>Bandwidth:</b> accepted:	fc +/- 20 Hz
<b>Amplitude twist:</b> accepted:	difference of 9 dB between frequency pair
Operating time:	< 64 msec.
Release time:	< 64 msec.
Tone Interrupt causing no release:	< 8 msec. Receiver on, tone missing
Longest Input tone ignored:	< 8 msec. Combination of valid frequencies
Longest control tone ignored:	< 15 msec. Control Frequency only
Noise rejection:	S/N > 18 dB No degradation in-band white noise

## Physical specifications

Table 147 outlines the physical specifications of the NT5K21 XMFC/MFE circuit card.

**Table 147**  
**Physical specifications (Part 1 of 2)**

Dimensions	Height: 12.5 in. (320 mm) Depth: 10.0 in. (255 mm) Thickness: 7/8 in. (22.25 mm)
Faceplate LED	Lit when the circuit card is disabled



**Table 147**  
**Physical specifications (Part 2 of 2)**

Cabinet Location	Must be placed in the main cabinet (Slots 1-10)
Power requirements	1.1 Amps typical
Environmental considerations	Meets the environment of the system



---

# NT6D70 SILC Line card

---

## Contents

This section contains information on the following topics:

Introduction . . . . .	379
Physical description . . . . .	380
Functional description . . . . .	380

## Introduction

The S/T Interface Line card (SILC) (NT6D70AA –48V North America, NT6D70 BA –40 V International) provides eight S/T four-wire full-duplex interfaces to connect ISDN BRI-compatible terminals over Digital Subscriber Loops (DSLs) to the System. A description of the ISDN BRI feature is contained in *ISDN Basic Rate Interface: Installation and Configuration* (553-3001-218).

You can install this card in any IPE slot.

**Note:** A maximum of four NT6D70 SILC cards are supported in an MG 1000S. A maximum of four NT6D70 SILC cards are supported in an MG 1000S Expansion.

## ISDN BRI

ISDN BRI consists of two 64Kb/s Bearer (B) channels and one 16Kb/s Data (D) channel. The BRI interface is referred to as a 2B+D connection as well as a Digital Subscriber Loop (DSL).

B-channels transmit user voice and data information at high speeds, while D-channels are packet-switched links that carry call set-up, signaling and other user data across the network.

One single DSL can carry two simultaneous voice or data conversations to the same or to different locations. In either case, the D-channel can also be used for packet communication to a third location simultaneously. The two B-channels can also be combined to transmit data at uncompressed speeds of up to 128 Kbps.

A wide range of devices and telephone numbers can be associated with a single DSL to offer equipment flexibility and reduce line, wiring, and installation costs.

## Physical description

The NT6D70 SILC card is a standard-size circuit card. Its faceplate is equipped with an LED to indicate its status.

## Power consumption

Power consumption is +5 V at 800 mA and -48 V at 480 mA.

## Foreign and surge voltage protections

In-circuit protection against power line crosses or lightning is not provided on the SILC card. When the SILC card is used in TIE trunk applications in which the cabling is exposed to outside plant conditions, an NT1 module certified for such applications must be used. Check local regulations before providing such service.

## Functional description

The NT6D70 SILC card provides eight S/T four-wire full-duplex polarity-sensitive interfaces to connect ISDN BRI-compatible terminals over Digital Subscriber Loops (DSL) to the system. Each S/T interface provides two B-channels and one D-channel and supports a maximum of eight physical connections that can link up to 20 logical terminals on one DSL.

A logical terminal is any terminal that can communicate with the system over a DSL. It can be directly connected to the DSL through its own physical termination or be indirectly connected through a common physical termination.

The length of a DSL depends on the specific terminal configuration and the DSL wire gauge; however, it should not exceed 1 km (3,280 ft).

The SILC interface uses a four-conductor cable that provides a differential Transmit and Receive pair for each DSL. The SILC has options to provide a total of two watts of power on the Transmit or Receive leads, or no power at all. When this power is supplied from the S/T interface, the terminal devices must not draw more than the two watts of power. Any power requirements beyond this limit must be locally powered.

Other functions of the SILC are:

- support point-to-point and multi-point DSL terminal connections
- execute instructions received from the MISP to configure and control the S/T interfaces
- provide channel mapping between ISDN BRI format (2B+D) and system bus format
- multiplex 4 D-channels onto one timeslot
- perform activation and deactivation of DSLs
- provide loopback control of DSLs
- provide a reference clock to the clock controller

## **Micro Controller Unit (MCU)**

The Micro Controller Unit (MCU) coordinates and controls the operation of the SILC. It has internal memory, a reset and sanity timer, and a serial control interface.

The memory consists of 32 K of EPROM which contains the SILC operating program and 8 K of RAM used to store interface selection and other functions connected with call activities.

The reset and sanity timer logic resets the MCU.

The serial control interface is an IPE bus used by the MPU to communicate with the S/T transceivers.

## **IPE interface logic**

The IPE interface logic consists of a Card-LAN interface, an IPE bus interface, a maintenance signaling channel interface, a digital pad, and a clock controller and converter.

The Card-LAN interface is used for routine card maintenance, which includes polling the line cards to find the card slot where the SILC is installed. It also queries the status and identification of the card and reports the configuration data and firmware version of the card.

The IPE bus interface connects an IPE bus loop that has 32 channels operating at 64 kbps and one additional validation and signaling bit.

The Maintenance Signaling Channel (MSC) interface communicates signaling and card identification information from the system CPU to the SILC MCU. The signaling information also contains maintenance instructions.

The digital pad provides gain or attenuation values to condition the level of the digitized transmission signal according to the network loss plan. This sets transmission levels for the B-channel voice calls.

The clock recovery circuit recovers the clock from the local exchange.

The clock converter converts the 5.12-MHz clock from the IPE backplane into a 2.56 MHz clock to time the IPE bus channels and an 8 kHz clock to provide PCM framing bits.

## **S/T interface logic**

The S/T interface logic consists of a transceiver circuit and the DSL power source. This interface supports DSLs of different distances and different numbers and types of terminal.

The transceiver circuits provide four-wire full-duplex S/T bus interface. This bus supports multiple physical terminations on one DSL where each physical termination supports multiple logical B-channel and D-channel ISDN BRI terminals. Idle circuit-switched B-channels can be allocated for voice or data transmission to terminals making calls on a DSL. When those terminals become idle, the channels are automatically made available to other terminals making calls on the same DSL.

The power on the DSL comes from the SILC, which accepts  $-48$  V from the IPE backplane and provides two watts of power to physical terminations on each DSL. It provides  $-48$  V for ANSI-compliant ISDN BRI terminals and  $-40$  V for CCITT (such as ETSI NET-3, INS NET-64) compliant terminals. The total power used by the terminals on each DSL must not exceed two watts.





---

# NT6D71 UILC Line card

---

## Contents

This section contains information on the following topics:

<a href="#">Introduction</a> . . . . .	385
<a href="#">Physical description</a> . . . . .	385
<a href="#">Functional description</a> . . . . .	386

## Introduction

The NT6D71 U Interface Line card (UILC) supports the OSI physical layer (layer 1) protocol. The UILC is an ANSI-defined standard interface. The UILC provides eight two-wire full-duplex (not polarity sensitive) U interfaces to connect ISDN BRI-compatible terminals over Digital Subscriber Loops (DSL) to the CS 1000S, CS 1000M, and Meridian 1. A description of the ISDN BRI feature is contained in *ISDN Basic Rate Interface: Installation and Configuration* (553-3001-218).

You can install this card in any IPE slot.

**Note:** A maximum of four UILCs are supported in an MG 1000S. A maximum of four UILCs are supported in an MG 1000S Expansion.

## Physical description

The NT6D71 UILC is a standard-size circuit card. Its faceplate is equipped with an LED to indicate its status.

## Power consumption

Power consumption is +5 V at 1900 mA.

## Functional description

Each U interface provides two B-channels and one D-channel and supports one physical termination. This termination can be to a Network Termination (NT1) or directly to a single U interface terminal. Usually, this physical termination is to an NT1, which provides an S/T interface that supports up to eight physical terminal connections. The length of a DSL depends on the specific terminal configuration and the DSL wire gauge; however, it should not exceed 5.5 km (3.3 mi).

The main functions of the UILC are as follows:

- provide eight ISDN U interfaces conforming to ANSI standards
- support point-to-point DSL terminal connections
- provide channel mapping between ISDN BRI format (2B+D) and system bus format
- multiplex four D-channels onto one timeslot
- perform activation and deactivation of DSLs
- provide loopback control of DSLs

## Micro Controller Unit (MCU)

The Micro Controller Unit (MCU) coordinates and controls the operation of the UILC. It has internal memory, a reset and sanity timer, a serial control interface, a maintenance signaling channel, and a digital pad.

The memory consists of 32 K of EPROM that contains the UILC operating program and 8 K of RAM that stores interface selection and other functions connected with call activities.

The reset and sanity timer logic resets the MCU.

The serial control interface is an IPE bus that communicates with the U transceivers.

## **IPE interface logic**

The IPE interface logic consists of a Card-LAN interface, a IPE bus interface, a maintenance signaling channel interface, a digital pad, and a clock converter.

The Card-LAN interface is used for routine card maintenance, which includes polling the line cards to find in which card slot the UILC is installed. It also queries the status and identification of the card and reports the configuration data and firmware version of the card.

The IPE bus interface connects one IPE bus loop that has 32 channels operating at 64 kbps and one additional validation and signaling bit.

The Maintenance Signaling Channel (MSC) interface communicates signaling and card identification information from the system CPU to the UILC MCU. The signaling information also contains maintenance instructions.

The digital pad provides gain or attenuation values to condition the level of the digitized transmission signal according to the network loss plan. This sets transmission levels for B-channel voice calls.

The clock converter converts the 5.12 MHz clock from the IPE backplane into a 2.56 MHz clock to time the IPE bus channels and an 8-kHz clock to provide PCM framing bits.

## **U interface logic**

The U interface logic consists of a transceiver circuit. It provides loop termination and high-voltage protection to eliminate the external hazards on the DSL. The U interface supports voice and data terminals, D-channel packet data terminals, and NT1s. A UILC has eight transceivers to support eight DSLs for point-to-point operation.



---

# NT6D80 MSDL card

---

## Contents

This section contains information on the following topics:

<a href="#">Introduction</a> . . . . .	389
<a href="#">Physical description</a> . . . . .	390
<a href="#">Functional description</a> . . . . .	392
<a href="#">Engineering guidelines</a> . . . . .	397
<a href="#">Installation</a> . . . . .	404
<a href="#">Maintenance</a> . . . . .	413
<a href="#">Replacing MSDL cards</a> . . . . .	421
<a href="#">Symptoms and actions</a> . . . . .	422
<a href="#">System disabled actions</a> . . . . .	423

## Introduction

This document describes the Multi-purpose Serial Data Link (MSDL) card. This card provides multiple interface types with four full-duplex serial I/O ports that can be independently configured for various operations. Peripheral software downloaded to the MSDL controls functionality for each port. Synchronous operation is permitted on all MSDL ports. Port 0 can be configured as an asynchronous Serial Data Interface (SDI).

An MSDL card occupies one network card slot in Large System Networks, or Core Network modules and communicates with the CPU over the CPU bus and with I/O equipment over its serial ports. It can coexist with other cards

that support the same functions. For example, three cards supported with the MSDL (NT6D80) are QPC757 (DCHI), QPC513 (ESDI), QPC841 (SDI) and NTSD12 (DDP).

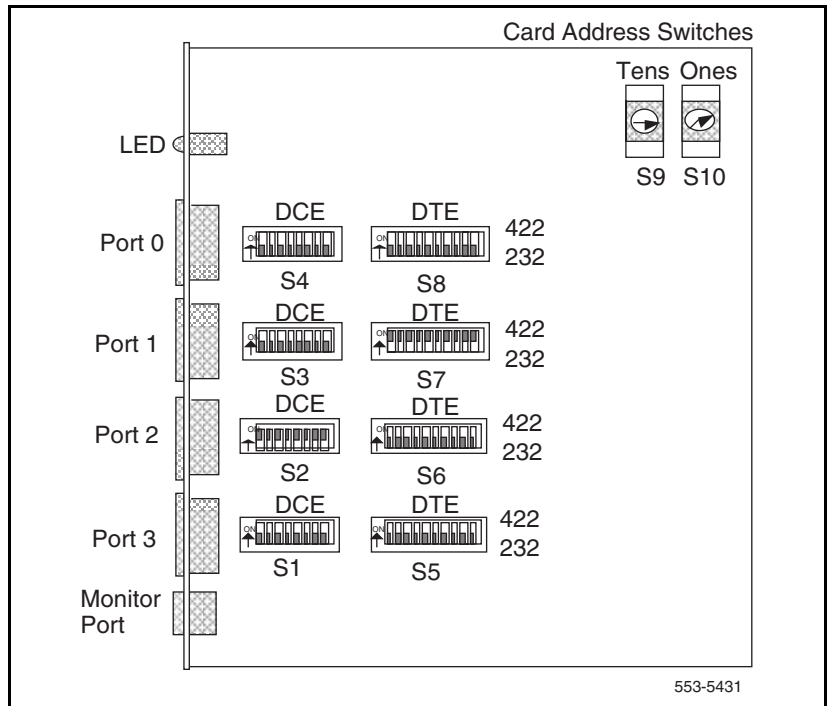
Though the MSDL is designed to coexist with other cards, the number of ports supported by a system equipped with MSDL cards is potentially four times greater than when using other cards. Since each MSDL has four ports, representing a single device, a system can support as many as 16 MSDL cards with a maximum of 64 ports.

## Physical description

The MSDL card is a standard size circuit card that occupies one network card slot and plugs into the module's backplane connector to interface with the CPU bus and to connect to the module's power supply. On the faceplate, the MSDL provides five connectors, four to connect to I/O operations and one to connect to a monitor device that monitors MSDL functions. Figure 82 on [page 391](#) illustrates major MSDL components and their locations on the printed circuit card.

**Note:** Switches S9 and S10 are configured to reflect the device number set in LD 17 (DNUM). S10 designates tens, and S9 designates ones. For example, set device number 14 with S10 at 1 and S9 at 4.

**Figure 82**  
**MSDL component layout**



## Functional description

Figure 83 on [page 393](#) illustrates the MSDL functional block diagram. The MSDL card is divided into four major functional blocks:

- CPU bus interface
- Micro Processing Unit (MPU)
- Memory
- Serial interface

Two processing units serve as the foundation for the MSDL operation: the Central Processing Unit (CPU) and the MSDL Micro Processing Unit (MPU). CS 1000 Release 4.5 software, MSDL firmware, and peripheral software control MSDL parameters. Peripheral software downloaded to the MSDL controls MSDL operations.

The MSDL card's firmware and software do the following:

- communicate with the CPU to report operation status
- receive downloaded peripheral software and configuration parameters
- coordinate data flow in conjunction with the CPU
- manage data link layer and network layer signaling that controls operations connection and disconnection
- control operation initialization and addressing
- send control messages to the operations

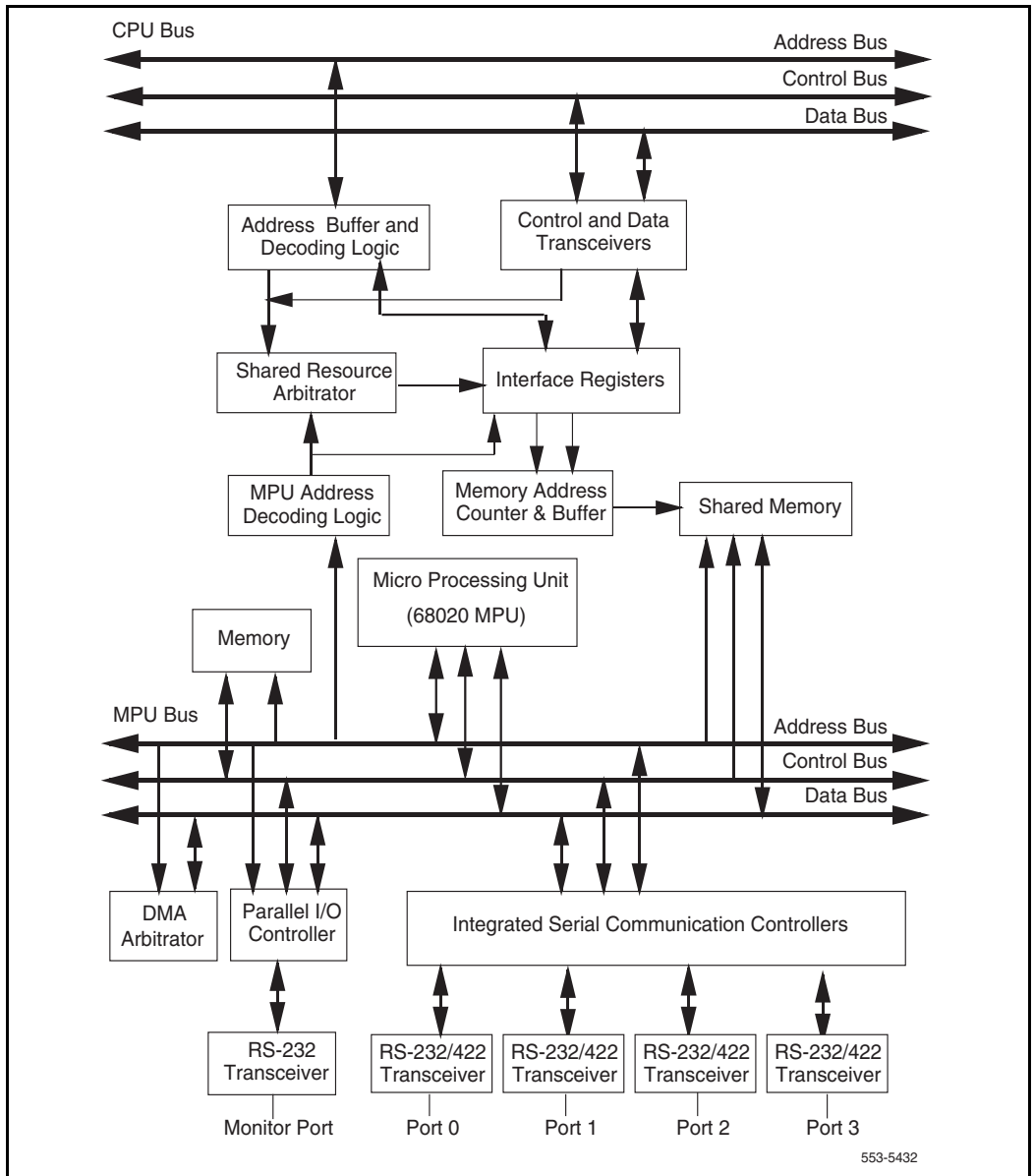
### CPU bus interface

The CPU bus transmits packetized information between the CPU and the MSDL MPU. This interface has a 16-bit data bus, an 18-bit address bus, and interrupt and read/write control lines.

Shared Random Access Memory (RAM) between the CPU and the MSDL MPU provides an exchange medium. Both the CPU and the MSDL MPU can access this memory.



**Figure 83**  
**MSDL block diagram**



## Micro Processing Unit (MPU)

The MPU, which is based on a Motorola 68020 processor, coordinates and controls data transfer and port addressing, communicating via the CPU bus with the system. Prioritized interrupts tell the MPU which tasks to perform.

## Memory

The MSDL card contains two megabytes of Random Access Memory (RAM) for storing downloaded peripheral software that controls MSDL port operations. The MSDL card includes the shared RAM that is used as a communication interface buffer between the CPU and the MPU.

The MSDL Flash Erasable Programmable Read Only Memory (Flash EPROM) also includes the peripheral software to protect it against a power failure or reset. MSDL can copy peripheral software directly from the Flash EPROM after power up or reset instead of requesting that the system CPU download it.

The MSDL card also contains Programmable Read Only Memory (PROM) for firmware that includes the bootstrap code.

## Serial interface

The MSDL card provides one monitor port and four programmable serial ports that can be configured for the following various interfaces and combinations of interfaces:

- synchronous ports 0–3
- asynchronous port 0
- DCE or DTE equipment emulation mode
- RS-232 or RS-422 interface

**Transmission mode** – All four ports of the MSDL can be configured for synchronous data transmission by software. Port 0 can be configured for asynchronous data transmission for CRT, TTY, and printer applications only.

**Equipment emulation mode** – Configure an MSDL port to emulate DCE or DTE by setting switches on the card and downloading LD 17 interface parameters.

**I/O port electrical interface** – Each MSDL port can be configured as an RS-232 or RS-422 interface by setting the switches on the MSDL card. MSDL ports use Small Computer Systems Interface (SCSI) II 26-pin female connectors.

Figure 84 on [page 396](#) shows the system architecture using the MSDL as an operational platform. It illustrates operation routing from the CPU, through the MSDL, to the I/O equipment. It also shows an example in which DCH operation peripheral software in the MSDL controls functions on ports 2 and 3.

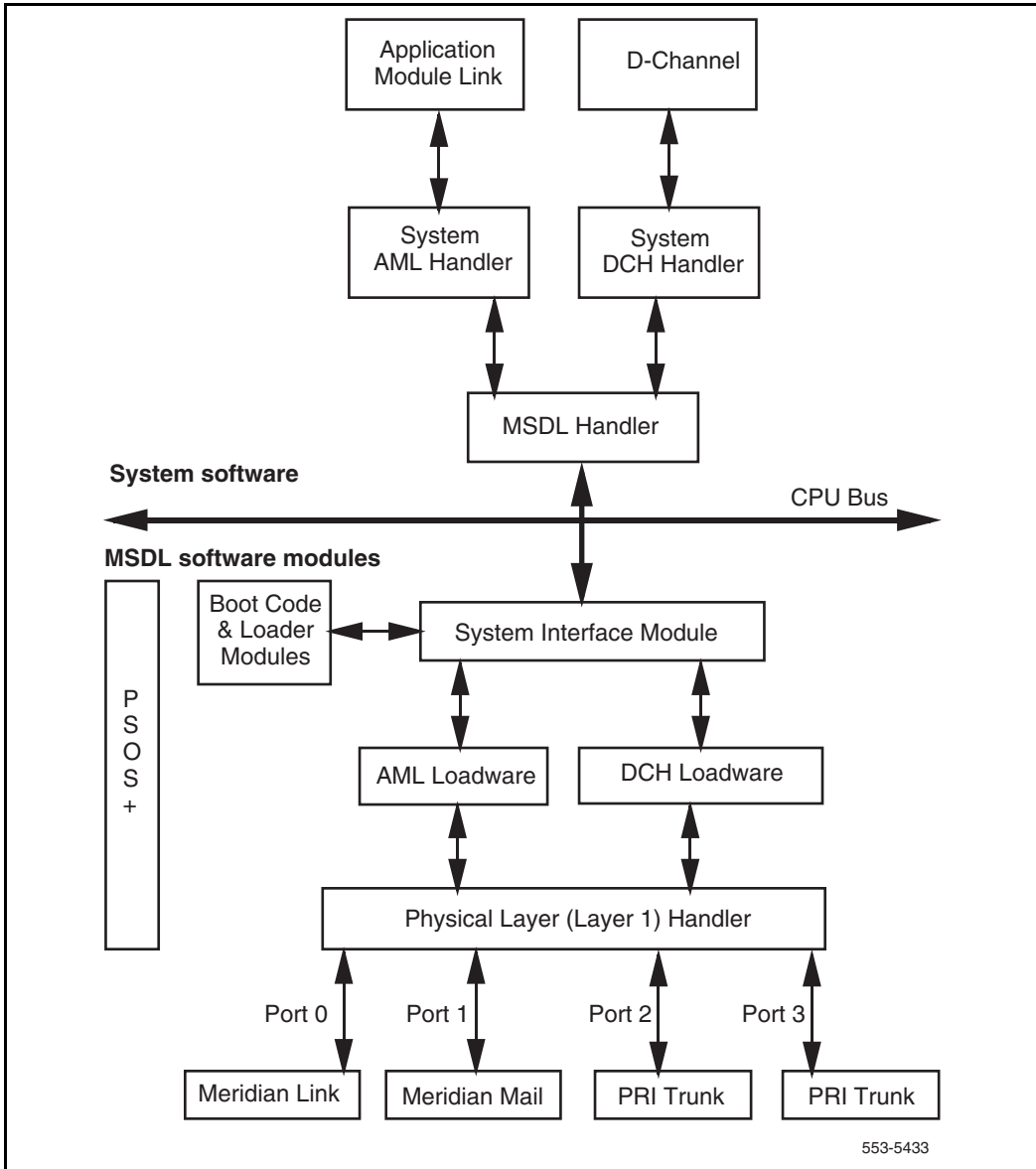
## MSDL operations

The system automatically performs self-test and data flow activities. Unless a permanent problem exists and the system cannot recover, there is no visual indication that these operations are taking place.

The system controls the MSDL card with software that it has downloaded. The MSDL and the system enable the MSDL by following these steps:

- 1** When the MSDL card is placed in the system, the card starts a self-test.
- 2** When the MSDL passes the test, it indicates its state and L/W version to the system. The CPU checks to see if downloading is required.
- 3** After downloading the peripheral software, the system enables the MSDL.
- 4** MSDL applications (DCH, AML, SDI) may be brought up if appropriately configured.

Figure 84  
MSDL functional block diagram



## Data flow

The MSDL transmit interface, managed by the MSDL handler, sends data from the system to the MSDL. This interface receives packetized data from the system and stores it in the transmit buffer on the MSDL. The transmit buffer transports these messages to the appropriate buffers, from which the messages travel over the MSDL port to the I/O equipment.

The MSDL uses the MSDL receive interface to communicate with the system. The MSDL card receives packetized data from the I/O equipment over the MSDL ports. This data is processed by the MSDL handler and sent to the appropriate function.

The flow control mechanism provides an orderly exchange of transmit and receive messages for each operation. Each operation has a number of outstanding messages stored in buffers waiting to be sent to their destinations. As long as the number of messages does not exceed the threshold specified, the messages queue in the buffer in a first-in-first-out process.

If the outstanding number of messages for an operation reaches the threshold, the flow control mechanism informs the sender to wait until the number of messages is below the threshold before sending the next message.

If buffer space is not available, the request to send a message to the buffer is rejected and a NO BUFFER fault indication is sent.

## Engineering guidelines

### Available network card slots

The number of available network slots depends on the system option, the system size, and the number of available network slots in each module for the selected system option.

Some of these network card slots are normally occupied by Network cards, Superloop Network cards, Conference/TDS, and others, leaving a limited number of unused slots for MSDL and other cards.

## Card mix

A system that exclusively uses MSDL cards can support up to 16 such cards, providing 64 ports. These ports can be used to run various synchronous and asynchronous operations simultaneously.

The system will also support a mix of interface cards (MSDL, DCHI, and ESDI for example). However, using multiple card types will reduce the number of cards and ports available.

## Address decoding

The MSDL card decodes the full address information received from the system. This provides 128 unique addresses. Since MSDL ports communicate with the CPU using a single card address, the system can support 16 MSDL cards providing 64 ports.

The MSDL card addresses are set using decimal switches located on the card. These switches can select 100 unique card addresses from 0 to 99.

An address conflict may occur between the MSDL and other cards because of truncated address decoding by the other cards. For example, if a DCHI port is set to address 5, its companion port will be set to address 4, which means that none of the MSDL cards can have hexadecimal address numbers 05H, 15H, ...75H, nor addresses 04H, 14H, ...74H. To avoid this conflicts system software limits the MSDL card addresses from 0 to 15.

## Port specifications

The MSDL card provides four programmable serial ports configured with software as well as with switches for the following modes of operation:

**Transmission mode** Configure an MSDL port for synchronous or asynchronous data transmission using LD 17.

Synchronous transmission uses an external clock signal fed into the MSDL.

Table 148 lists the synchronous interface specifications and the means of configuring the interface parameters.

**Table 148**  
**Synchronous interface specifications**

<b>Parameter</b>	<b>Specification</b>	<b>Configured</b>
Data bits	In packets-Transparent	N/A
Data rate	1.2, 2.4, 4.8, 9.6, 19.2, 38.4, 48, 56, and 64 kbps	Software
Transmission	Full Duplex	N/A
Clock	Internal/External	Software
Interface	RS-232	Software
	RS-422	Switches
Mode	DTE or DCE	Switches

Asynchronous transmission uses an internal clock to generate the appropriate baud rate for serial controllers.

Table 149 lists asynchronous interface specifications and the means of configuring interface parameters.

**Table 149**  
**Asynchronous interface specifications (Part 1 of 2)**

<b>Parameter</b>	<b>Specification</b>	<b>Configured</b>
Data bit, parity	7 bits even, odd or no parity, or 8 bits no parity	Software
Data rate	0.3, 0.6, (1.2), 2.4, 4.8, 9.6, 19.2, and 38.4 kbps	Software
Stop bits	1 (default), 1.5, 2	Software
Transmission	Full Duplex	N/A
Interface	RS-232	Software

**Table 149**  
**Asynchronous interface specifications (Part 2 of 2)**

Parameter	Specification	Configured
	RS-422	Switches
Mode	DTE or DCE	Switches

**Emulation mode** Each port can be configured to emulate a DCE port or a DTE port by setting the appropriate switches on the MSDL. For details on how to set the switches, refer to “Installation” on [page 404](#) of this document.

DCE is a master or controlling device that is usually the source of information to the DTE and may provide the clock in a synchronous transmission linking a DCE to a DTE.

DTE is a peripheral or terminal device that can transmit and receive information to and from a DCE and normally provides a user interface to the system or to a DCE device.

**Interface** Each MSDL port can be configured as an RS-232 or an RS-422 interface by setting the appropriate switches on the card.

Table 150 lists the RS-232 interface specifications for EIA and CCITT standard circuits. It shows the connector pin number, the associated signal name, and the supported circuit type. It also indicates whether the signal originates at the DTE or the DCE device.

This interface uses a 26-pin (SCSI II) female connector for both RS-232 and RS-422 circuits.

**Table 150**  
**RS-232 interface pin assignments (Part 1 of 2)**

Pin	Signal name	EIA circuit	CCITT circuit	DTE	DCE
1	Frame Ground (FG)	AA	102	—	—
2	Transmit Data (TX)	BA	103	X	



**Table 150**  
**RS-232 interface pin assignments (Part 2 of 2)**

Pin	Signal name	EIA circuit	CCITT circuit	DTE	DCE
3	Receive Data (RX)	BB	104		X
4	Request to Send (RTS)	CA	105	X	
5	Clear to Send (CTS)	CB	106		X
6	Data Set Ready (DSR)	CC	107		X
7	Signal Ground (SG)	AB	102	—	—
8	Carrier Detect (CD)	CF	109		X
15	Serial Clock Transmit (SCT)	DB	114		X
17	Serial Clock Receive (SCR)	DD	115		X
18	Local Loopback (LL)	LL	141	X	
20	Data Terminal Ready (DTR)	CD	108.2	X	
21	Remote Loopback (RL)	RL	140	X	
23	Data Rate Selector (DRS)	CH/CI	111/112	X	
24	External Transmit Clock (ETC)	DA	113	X	
25	Test Mode (TM)	TM	142		X

Table 151 on [page 402](#) lists RS-422 interface specifications for EIA circuits. It shows the connector pin number, the associated signal name, and the

supported circuit type. It also indicates whether the signal originates at the DTE or DCE device.

**Table 151**  
**RS-422 interface pin assignments**

Pin	Signal Name	EIA Circuit	DTE	DCE
1	Frame Ground (FG)	AA	—	—
2	Transmit Data (TXa)	BAa	X	
3	Receive Data (RXa)	BBa		X
4	Request to Send (RTS)	CA	X	
5	Clear to Send (CTS)	CB		X
7	Signal Ground (SG)	AB	—	—
8	Receive Ready (RR)	CF		X
12	Receive Signal Timing (RST)	DDb		X
13	Transmit Data (TXb)	BAb		X
14	Transmit Signal Timing (TSTb)	DBb		X
15	Transmit Signal Timing (TSTa)	DBa		X
16	Receive Data (RXb)	BBb		X
17	Receive Signal Timing (RSTa)	DDa		X
20	Data Terminal Ready (DTR)	CD	X	
23	Terminal Timing (TTa)	DAb	X	
24	Terminal Timing (TTb)	DAa	X	

### Implementation guidelines

The following are guidelines for engineering and managing MSDL cards:

- An MSDL can be installed in any empty network card slot.

- A maximum of eight MSDL cards can be installed in a fully occupied module because of the module's power supply limitations.
- The Clock Controller card should not be installed in a module if more than 10 MSDL ports are configured as active RS-232 (rather than RS-422) ports in that module because of the module's power supply limitations.
- The MSDL address must not overlap other card addresses.
- Before downloading a peripheral software module for an MSDL, disable all MSDL ports on cards running the same type of operation.

## Environmental and power requirements

The MSDL card conforms to the same requirements as other interface cards. The temperature, humidity, and altitude for system equipment, including the MSDL, should not exceed the specifications shown in Table 152.

**Table 152**  
**Environmental requirements**

<b>Condition</b>	<b>Environmental specifications</b>
Operating	
Temperature	0° to 50° C (32° to 122° F)
Relative Humidity	5% to 95% non-condensing
Altitude	3,048 meters (10,000 feet) maximum
Storage	
Temperature	-50° to 70° C (-58° to 158° F)
Relative Humidity	5% to 95% non-condensing

A stable ambient operating temperature of approximately 22°C (72°F) is recommended. The temperature differential in the room should not exceed ±3°C (±5°F).

The internal power supply in each module provides DC power for the MSDL and other cards. Power consumption and heat dissipation for the MSDL is listed in Table 153.

**Table 153**  
**MSDL power consumption**

<b>Voltage (VAC)</b>	<b>Current (Amps)</b>	<b>Power (Watts)</b>	<b>Heat (BTUs)</b>
+5	3.20	16.00	55.36
+12	0.10	1.20	4.15
-12	0.10	1.20	4.15

## Installation

### Device number

Before installing MSDL cards, determine which of the devices in the system are available. If all 16 devices are assigned, remove one or more installed cards to replace them with MSDL cards.

Make sure that the device number assigned to the MSDL card is not used by an installed card, even if one is not configured. Use the MSDL planning form, at the end of this section, to assist in configuring MSDL cards.

### MSDL interfaces

Before installing the cards, select the switch settings that apply to your system, the interfaces, and card addresses.

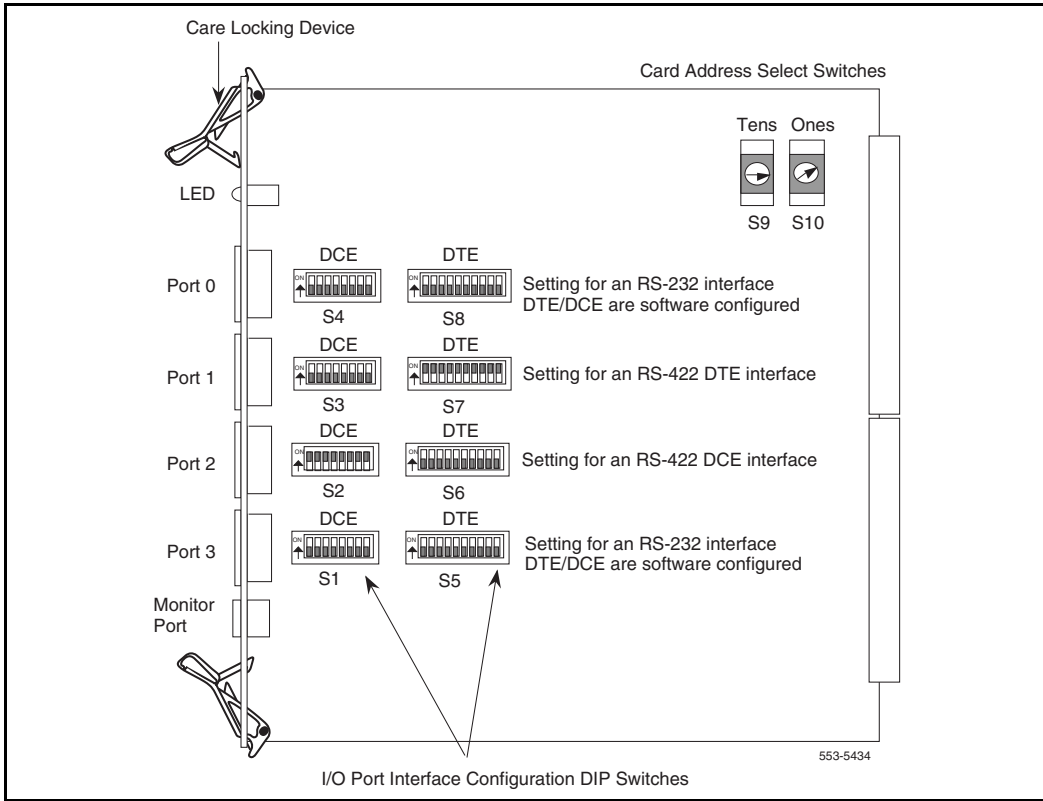
Table 154 on [page 405](#) shows the switch positions for the DCE and the DTE interface configurations on the MSDL card. Figure 85 on [page 406](#) shows the MSDL and the location of configuration switches on the MSDL. The switch

settings shown in this figure are an example of the different types of interfaces available. Your system settings may differ.

**Table 154**  
**MSDL interface switch settings**

<b>DCE switch</b>	<b>DTE switch</b>	<b>Interface</b>	<b>Comment</b>
OFF	OFF	RS-232	DTE/DCE is software configured
OFF	ON	RS-422 DTE	All switches configured
ON	OFF	RS-422 DCE	All switches configured
ON	ON	N/A	Not allowed

**Figure 85**  
**MSDL switch setting example**



## Installing the MSDL card

### **Procedure 16** **Installing the MSDL card**

To install an MSDL card follow these steps:

- 1** Set Device Number S10 and S9.
- 2** Hold the MSDL by its card-locking devices. Squeeze the tabs to unlatch the card locking devices and lift the locking device out and away from the card. Be careful not to touch connector pins, conductor traces, or integrated circuits. Static discharge may damage integrated circuits.
- 3** Insert the MSDL card into the selected card slot of the module following the card guides in the module.
- 4** Slide the MSDL into the module until it engages the backplane connector.
- 5** Push the MSDL firmly into the connector using the locking devices as levers by pushing them toward the card's front panel.
- 6** Push the card-locking devices firmly against the front panel of the card so they latch to the front lip in the module and to the post on the card.
- 7** Observe the red LED on the MSDL faceplate. If it turns on, flashes three times, and stays on continuously, the MSDL is operating correctly but is not yet enabled. Go to step 7.
- 8** If the LED turns on and stays on continuously without flashing three times, the card may be defective. Go to steps 8 and 9.
- 9** Connect the cables. The installation is complete.
- 10** Unplug the MSDL card and reinsert it. If the red LED still does not flash three times, leave the card installed for approximately 10 minutes to allow the card to be initialized.
- 11** After 10 minutes unplug the card and reinsert it. If the card still does not flash three times, the card is defective and must be replaced.

---

**End of Procedure**

---

## Cable requirements

The MSDL card includes four high-density 26-pin (SCSI II) female connectors for ports and one 8-pin miniature DIN connector for the monitor port. See Figure 86 on [page 409](#) for a diagram of the MSDL cabling configuration.

A D-Channel on the MSDL requires a connection from the appropriate MSDL port connector to the DCH connector located on the ISDN PRI trunk faceplate.

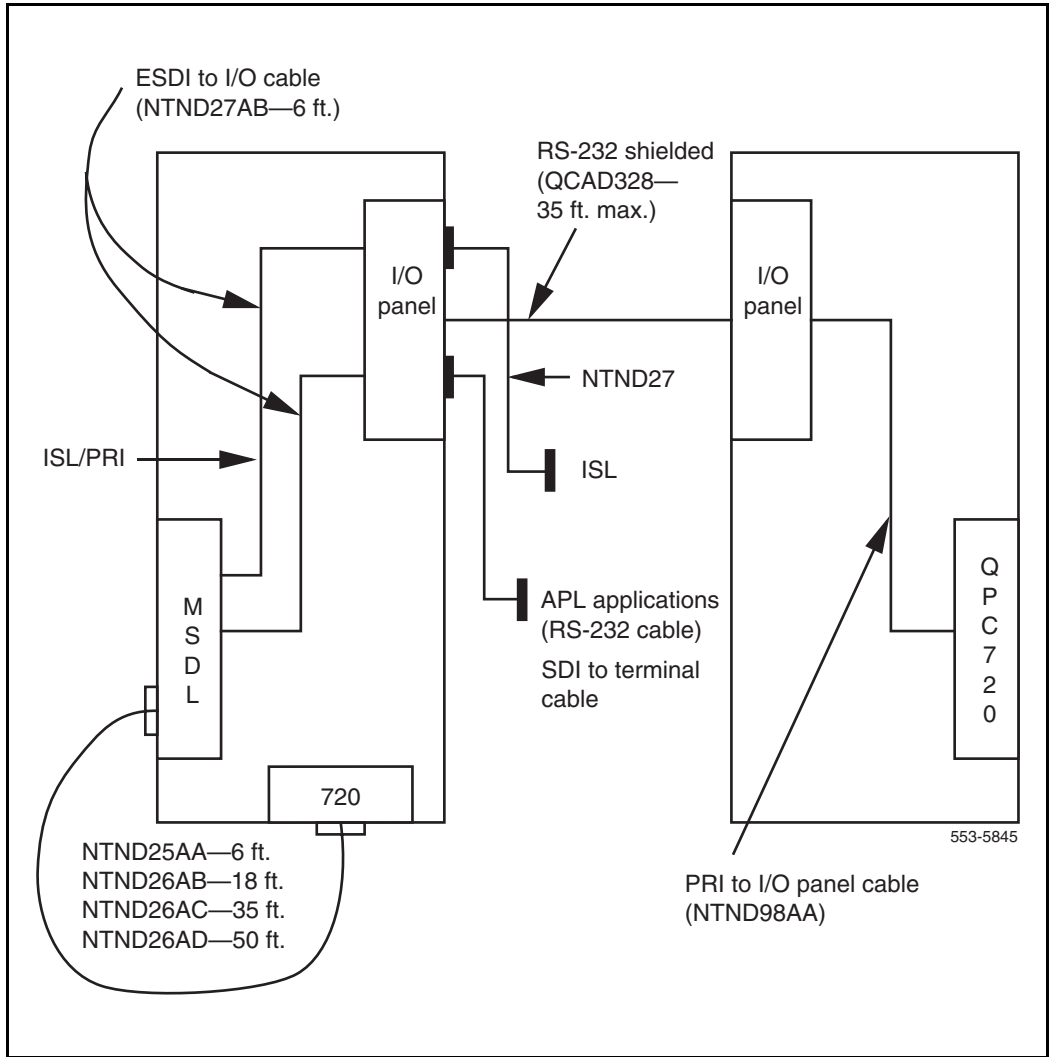
Other operations on the MSDL are connected to external devices such as terminals and modems. To complete one of these connections, connect the appropriate I/O connector on the MSDL to a connector on the I/O panel at the back of the module where the MSDL is installed. If a terminal is connected to the regular SDI port, use 8 bit, VT100 terminal emulation. If the terminal is connected to the SDI/STA port with line mode editing, use 8 bit, VT220 terminal emulation.

To determine the type and number of cables required to connect to MSDL cards, you must determine the type of operation you wish to run and select the appropriate cable to connect the operation to the MSDL port. Different types of cables, as described in Table 155 on [page 410](#), connect the MSDL port to a device:

- NTND26, used to connect the MSDL port to the ISDN PRI trunk connector J5, for DCH
- QCAD328, when cabling between two different columns, that is, I/O to I/O (when MSDL is in one row and QPC720 is in another row)
- NTND98AA (J5 of QPC720 to I/O panel)
- NTND27, used to connect the MSDL port to the I/O panel at the rear of the module, for other interface functions



Figure 86  
MSDL cabling



**Note:** The choices of cable to use with an MSDL card depend on what type of modem is connected. For example, the NTND27 cable is used when the modem has a DB25 connection. If the modem is v.35, a customized or external vendor cable is required.

**Table 155**  
**Cable types**

Function	Cable type	Cable length
DCH	NTND26AA	6 feet
	NTND26AB	18 feet
	NTND26AC	35 feet
	NTND26AD	50 feet
AML, ISL, SDI	NTND27AB	6 feet

## Cable installation

When the MSDL card is installed, connect the cables to the equipment required for the selected operation.

### PRI trunk connections

D-channel operations require connections between the MSDL and a PRI trunk card. Refer to *Meridian Link ISDN/AP General Guide* (553-2901-100) for a complete discussion of PRI and D-channels.

#### Procedure 17

##### Cabling the MSDL card to the PRI card

The following steps explain the procedure for cable connection:

- 1 Identify the MSDL and the PRI cards to be linked.
- 2 Select the appropriate length cable for the distance between the MSDL and the PRI card.
- 3 Plug the 26-pin SCSI II male connector end of a cable into the appropriate MSDL port.
- 4 Route the cable through cable troughs, if necessary, to the appropriate PRI card.

- 5 Plug the DB15 male connector end of the cable into the J5 DB15 female connector on the PRI card.
- 6 Secure the connections in place with their fasteners.
- 7 Repeat steps 1 through 6 for each connection.

---

**End of Procedure**

---

### **I/O panel connections**

Operations aside from PRI require cable connections to the I/O panel. Connections between the I/O panel and Application Equipment Modules (AEM) are described in “Application Module description,” *Meridian Link description* (553-3201-110).

#### **Procedure 18 Cabling the MSDL card to the I/O panel**

The following steps explain the procedure for cable connection:

- 1 Identify the MSDL card and the I/O panel connector to be linked.
- 2 Using the NTND27AB cable, plug the 26-pin SCSI II male connector end of a cable into the appropriate MSDL port.
- 3 Route the cable to the rear of the module next to the I/O panel.
- 4 Plug the DB25 male connector end of a cable into a DB25 female connector at the back of the I/O panel.
- 5 Secure cable connectors in place with their fasteners.
- 6 Repeat steps 1 through 5 for each connection.

---

**End of Procedure**

---

## MSDL planning form

Use the following planning form to help sort and store information concerning the MSDL cards in your system as shown in the sample. Record switch settings for unequipped ports as well as for equipped ports.

MSDL data form					
	Device no.	Shelf	Slot	Card ID	Boot Code version
	Date installed	Last update			
Ports	Operation	Logical no.	Switch setting	Cable no.	Operation information
0					
1					
2					
3					

Sample					
	Device no.	Shelf	Slot	Card ID	Boot Code version
	Date installed	Last update			
Ports	Operation	Logical no.	Switch setting	Cable no.	Operation information
	13	3	5	NT6D80AA-110046	004
	2/1/93	5/5/93			
0	TTY	13	RS-232 DCE	NTND27AB	maint TTY 9600 baud
1	DCH	25	RS-422 DTE	NTND26AB	PRI 27 to hdqtrs
2	AML	3	RS-232 DCE	NTND27AB	Meridian Mail
3	Spare		RS-232		

## Maintenance

Routine maintenance consists of enabling and disabling MSDL cards and downloading new versions of peripheral software. These activities are performed by an authorized person such as a system administrator.

Troubleshooting the MSDL consists of determining problem types, isolating problem sources, and solving the problem. A craftsperson normally performs these activities.

CS 1000S, CS 1000M, and Meridian 1 systems have self-diagnostic indicators as well as software and hardware tools. These diagnostic facilities simplify MSDL troubleshooting and reduce mean-time-to-repair (MTTR). For complete information concerning system maintenance, refer to *Communication Server 1000M and Meridian 1: Large System Maintenance* (553-3021-500).

For complete information regarding software maintenance programs, refer to *Software Input/Output: Administration* (553-3001-311).

## MSDL states

MSDL states are controlled manually by maintenance programs or automatically by the system. Figure 87 on [page 414](#) shows MSDL states and the transitions among them. These are the three states the MSDL may be in:

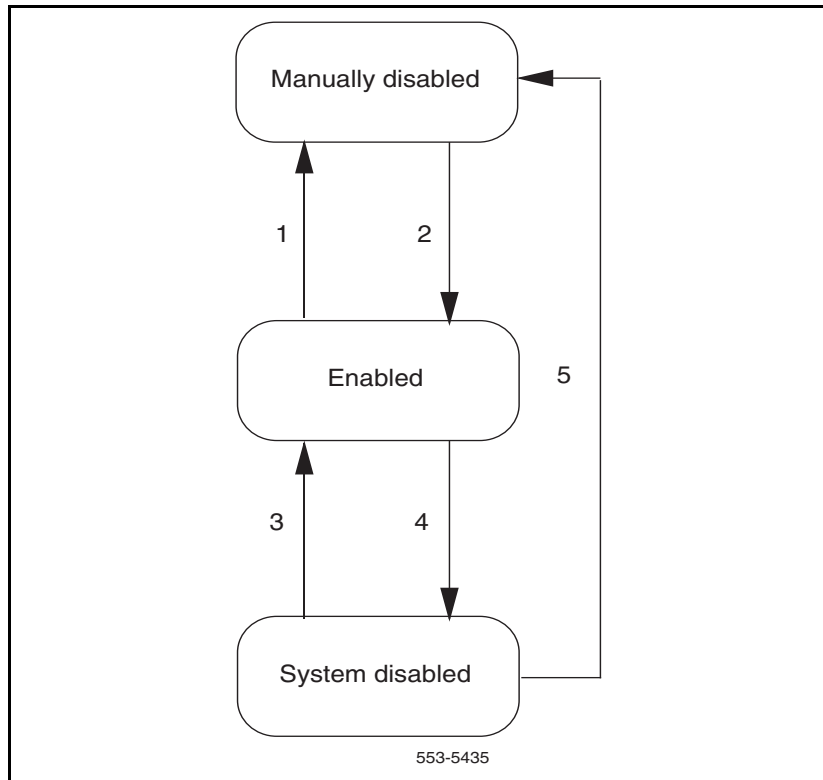
- Manually disabled
- Enabled
- System disabled

The following sections describe the relationships between these states.

### Manually disabled

In this state, the MSDL is not active. The system does not attempt to communicate or attempt any automatic maintenance on the MSDL.

**Figure 87**  
**MSDL states**



A newly configured MSDL automatically enters the manually disabled state. An operating MSDL can be manually disabled by issuing the **DIS MSDL x** command in LD 37 (step 1 in Figure 87).

Entering the **DIS MSDL x** command in LD 37 moves the card to manually disabled status and stops all system communication with the card (step 5 in Figure 87).

### **Manually enabled**

When the card has been manually disabled, re-enable it with the **ENL MSDL x** command in LD 37 (step 2 in Figure 87).

## System disabled

When the system disables the MSDL card (step 4 in Figure 87 on [page 414](#)), it continues to communicate and attempt maintenance procedures on the card. To stop all system communication with the card, enter **DIS MSDL x** to disable it (step 5 in Figure 87 on [page 414](#)). Otherwise, the system periodically tries to enable the card, attempting recovery during the midnight routines (step 3 in Figure 87 on [page 414](#)).

The system disables the MSDL if the card:

- exhibits an overload condition
- does not respond to system messages
- is removed
- resets itself
- encounters a fatal error
- is frequently system disabled and recovered

When an MSDL is system disabled, a substate indicates why the MSDL is disabled. The substates are:

- **Not Responding** The system cannot communicate with the MSDL.
- **Self-Testing** The MSDL card is performing self-tests.
- **Self-tests Passed** The MSDL card successfully completed self-tests and the system is determining if download is required or the software downloading is complete.
- **Self-tests Failed** The MSDL card self-tests failed.
- **Shared RAM Tests Failed** The system failed to read/write to the MSDL shared RAM.
- **Overload** The system received an excessive number of messages within a specified time period.
- **Reset Threshold** The system detected more than four resets within 10 minutes.
- **Fatal Error** The MSDL card encountered a fatal condition from which it cannot recover.

- **Recovery Threshold** The MSDL card was successfully enabled by the MSDL autorecovery function five times within 30 minutes. Each time it was system disabled because of a problem encountered during operation.
- **Bootloading** The MSDL base software is in the process of being downloaded to the MSDL.

Detailed information on system disabled substates and the action required for each substate appears in “Symptoms and actions” on [page 422](#).

## Maintaining the MSDL

The system controls automatic MSDL maintenance functions. A craftsperson or system administrator performs manual maintenance by changing the card status, downloading new versions of peripheral software, or invoking self-tests.

## System controlled maintenance

Built-in diagnostic functions constantly monitor and analyze the system and individual card, performing the following operations:

- using autorecovery to automatically correct a temporarily faulty condition and maintain the system and its components
- printing information and error messages to indicate abnormal conditions that caused a temporary or an unrecoverable error

During system initialization, the system examines the MSDL base code. If the base code needs to be downloaded, the CPU resets the MSDL card and starts downloading immediately following initialization. At the same time, all other MSDL peripheral software programs are checked and, if they do not correspond to the system disk versions, the correct ones are downloaded to the card.

If manual intervention is required during initialization or operation, information and error messages appear on the console or the system TTY to suggest the appropriate action. For a complete discussion of the information and error messages, refer to *Software Input/Output: Administration* (553-3001-311). Detailed information of system disabled substates and the action required for each substate is found at the end of this document.



## Manually controlled maintenance

Use manual maintenance commands found in the following programs to enable, disable, reset, get the status of, and perform self-tests on the MSDL card:

- Input/Output Diagnostic Program LD 37
- Program LD 42
- Link Diagnostic Program LD 48
- PRI D-channel Diagnostic Program LD 96

For a complete discussion of these programs, refer to *Software Input/Output: Administration* (553-3001-311).

**Note 1:** Enter commands after the dot (.) prompt.

**Note 2:** The “x” in the commands below represents the DNUM value of the card number.

### Enabling the MSDL

Enter **ENL MSDL x** to enable the MSDL manually. If the MSDL base code has not been previously downloaded or if the card version is different from the one on the system disk, the software is downloaded and the card is enabled.

To force software download and enable the card, enter **ENL MSDL x FDL**. This command forces the download of the MSDL base code and the configured peripheral software even if it is already resident on the card. The card is then enabled.

To enable a disabled MSDL and its ports, enter **ENL MSDL x ALL**. This command downloads all peripheral software (if required) and enables any configured ports on the card. This command can be issued to enable some manually disabled ports on an already enabled MSDL.

### **Disabling the MSDL**

To disable an MSDL card, enter **DIS MSDL x**.

To disable the MSDL and all its ports, enter **DIS MSDL x ALL**.

### **Resetting the MSDL**

To reset an MSDL and initiate a limited self-test, the MSDL must be in a manually disabled state. To perform the reset, enter **RST MSDL x**.

### **Displaying MSDL status**

To display the status of all MSDL cards, enter **STAT MSDL**.

To display the status of a specific MSDL, enter **STAT MSDL x**. The status of the MSDL, its ports, and the operation of each port appears.

The command **STAT MSDL x FULL** displays all information about an MSDL (card ID, bootload firmware version, base code version, base code state, operation state, date of base code activation) as well as the version, state, and activation date for each card operation.

### **Self-testing the MSDL**

To perform extensive self-testing of an MSDL, enter **SLFT MSDL x**. This test can be activated if the card is in the manually disabled state. If the test passes, the system outputs the card ID and a pass message. If it fails, the system displays a message indicating which test failed.

## Manually isolating and correcting faults

Problems are due to configuration errors that occur during installation or hardware faults resulting from component failure during operation. See “Symptoms and actions” on [page 422](#) for more information on problem symptoms and required responses.

Isolate MSDL faults using the diagnostic tools described below:

- 1** Observe and list the problem symptoms; for example, a typical symptom is a permanently lit LED.
- 2** If the LED flashes three times but the card does not enable, verify that the card is installed in a proper slot.
- 3** Check that the address is unique; no other card in the system can be physically set to the same device number as the MSDL.
- 4** If installation is correct and no address conflict exists, refer to “Newly installed MSDL cards” on [page 419](#) or “Previously operating MSDL cards” on [page 420](#).
- 5** If the MSDL still does not operate correctly, contact your Nortel representative.

### Newly installed MSDL cards

Problems that occur during MSDL card installation usually result from improperly installed, incorrectly addressed, or faulty cards.

If the LED on a newly installed MSDL does not flash three times after insertion, wait 5 minutes, then remove and reinsert. If the LED still does not flash three times, the card is faulty.

### Previously operating MSDL cards

Problems that occur during normal operation usually result from faulty cards. Follow these steps to evaluate the situation:

- 1 Use the **STAT MSDL x** command to check MSDL card status. See “Displaying MSDL status” on [page 418](#).
- 2 If the card has been manually disabled, try to enable it using **ENL MSDL x**. See “Enabling the MSDL” on [page 417](#). If this fails, perform self-testing as described in step 4.
- 3 If the card has been disabled by the system, disable it manually with **DIS MSDL x**. See “Disabling the MSDL” on [page 418](#).
- 4 Invoke self-testing with the **SLFT MSDL x** command. See “Self-testing the MSDL” on [page 418](#). If self-tests fail, replace the card. If self-tests pass, try to enable the card again, as in step 2. If the card does not enable, note the message output to the TTY and follow the recommended action.

---

## Replacing MSDL cards

After completing MSDL troubleshooting you may determine that one or more MSDL cards are defective. Remove the defective cards and replace them with new ones.

### Procedure 19 Replacing an MSDL card

An MSDL card can be removed from and inserted into a system module without turning off the power to the module. Follow these steps:

- 1 Log in on the maintenance terminal.
- 2 At the > prompt, type **LD 37** (you can also use LD 42, LD 48, or LD 96) and press Enter.
- 3 Type **DIS MSDL x ALL** and press Enter to disable the MSDL and any active operations running on one or more of its ports. The MSDL card is now disabled.
- 4 Disconnect the cables from the MSDL faceplate connectors.
- 5 Unlatch the card-locking devices, and remove the card from the module.
- 6 Set the switches on the replacement card to match those on the defective card.
- 7 Insert the replacement card into the same card slot.
- 8 Observe the red LED on the front panel during self-test. If it flashes three times and stays on, it has passed the test. Go to step 8.
- 9 If it does not flash three times and then stay on, it has failed the test. Pull the MSDL partially out of the module and reinsert it firmly into the module. If the problem persists, troubleshoot or replace the MSDL.
- 10 Connect the cables to the MSDL faceplate connectors.
- 11 At the . prompt in the **LD 37** program, type **ENL MSDL x ALL** and press Enter to enable the MSDL and its operations. If the red LED on the MSDL turns off, the MSDL is functioning correctly. Since self-tests were not invoked, no result message appears.
- 12 Tag the defective card(s) with a description of the problem and return them to your Nortel representative.

---

**End of Procedure**

---

## Symptoms and actions

Explained here are some of the symptoms, diagnoses, and actions required to resolve MSDL card problems. Contact your Nortel representative for further assistance.

These explain the causes of problems and the actions needed to return the card to an enabled state following installation or operational problems.

**Symptom:** The LED on the MSDL card is steadily lit.

**Diagnosis:** The MSDL card is disabled or faulty.

**Action:** Refer to “Manually isolating and correcting faults” on [page 419](#).

or

**Diagnosis:** Peripheral software download failed because of MSDL card or system disk failure.

**Action:** If only one MSDL card has its LED lit, replace it.

**Symptom:** Autorecovery is activated every 30 seconds to enable the MSDL. MSDL300 messages appear on the console or TTY.

**Diagnosis:** The MSDL card has been system disabled because of an incorrect address.

**Action:** Verify the switch settings.

or

**Diagnosis:** The MSDL card has been system disabled because of peripheral software or configuration errors.

**Action:** Refer to “System disabled actions” on [page 423](#).

---

## System disabled actions

These explain the causes of problems and the actions needed to return the card to an enabled state following system disabling.

### SYSTEM DISABLED—NOT RESPONDING

**Cause:** The MSDL card is not installed or is unable to respond to the messages from the system.

**Action:**

Check the MSDL messages on the console and take the action recommended. Refer to *Software Input/Output: Administration* (553-3001-311).

Verify that the address switches on the MSDL are set correctly.

Verify that the card is properly installed in the shelf for at least 5 minutes.

If the problem persists, manually disable the card by entering the **DIS MSDL x**. Follow the steps described in “Previously operating MSDL cards” on [page 420](#).

### SYSTEM DISABLED—SELF-TESTING

**Cause:** The MSDL card has reset itself or the system has reset the card to perform self-tests. Self-tests are in progress.

**Action:**

Wait until self-tests are completed. Under some circumstances, the self-tests may take up to 6 minutes to complete.

Take the action described in the appropriate section below (“SYSTEM DISABLED—SELF-TESTS PASSED” or “SYSTEM DISABLED—SELF-TESTS FAILED”).

### SYSTEM DISABLED—SELF-TESTS PASSED

**Cause:** The MSDL card passed self-tests. The system will automatically download the MSDL base code, if needed, and attempt to enable the card

using autorecovery. If a diagnostic program (overlay) is active, the downloading of the MSDL base code occurs later.

**Action:**

Wait to see if the system will enable the card immediately. If the MSDL is enabled, no further action is necessary.

If the MSDL base code download fails five times, autorecovery stops. The following appears in response to the **STAT MSDL x** command;

```
MSDL 10: SYS DSBL-SELFTEST PASSED
NO RECOVERY UNTIL MIDNIGHT: FAILED BASE DNLD 5
TIMES
      SDI  10  DIS  PORT 0
      AML  11  DIS  PORT 1
      DCH  12  DIS  PORT 2
      AML  13  DIS  PORT 3
```

Error messages will usually indicate the problem in this case. See “Maintaining the MSDL” on [page 416](#).

**SYSTEM DISABLED—SELF-TESTS FAILED**

**Cause:** The card did not pass self-tests. These tests repeat five times. If unsuccessful, autorecovery stops until midnight unless you take action.

**Action:**

Allow the system to repeat the self-tests.

If self-tests fail repeatedly, disable the card using the **DIS MSDL x** command and replace the card.

**SYSTEM DISABLED—SRAM TESTS FAILED**

**Cause:** After self-tests passed, the system attempted to perform read/write tests to the shared RAM on the MSDL and detected a fault. The shared RAM test will be repeated five times, and, if unsuccessful, autorecovery will not resume until midnight unless you take action.

**Action:**

Allow the system to repeat the self-tests.

If self-tests fail repeatedly, disable the card using the **DIS MSDL x** command and replace the card.



## SYSTEM DISABLED—OVERLOAD

**Cause:** The system received an excessive number of messages from the MSDL card in a certain time. If the card invokes overload four times in 30 minutes, it exceeds the recovery threshold as described in “SYSTEM DISABLED—RECOVERY THRESHOLD.” The system resets the card, invokes self-tests, and attempts to enable the card. The problem may be due to excessive traffic on one or more MSDL ports. Traffic load redistribution may resolve this condition.

**Action:**

Check the traffic report, which may indicate that one or more MSDL ports are handling excessive traffic.

By disabling each port, identify the port with too much traffic and allow the remaining ports to operate normally. Refer to “Maintaining the MSDL” on [page 416](#). If the problem persists, place the card in the manually disabled state by the **DIS MSDL x** command and follow the steps in “Previously operating MSDL cards” on [page 420](#).

## SYSTEM DISABLED—RESET THRESHOLD

**Cause:** The system detected more than four MSDL card resets within 10 minutes. The system attempts to enable the card again at midnight unless you intervene.

**Action:**

Place the card in the manually disabled state with the **DIS MSDL x** command and follow the steps in “Previously operating MSDL cards” on [page 420](#).

## SYSTEM DISABLED—FATAL ERROR

**Cause:** The MSDL card encountered a fatal error and cannot recover. The exact reason for the fatal error is shown in the MSDL300 error message output to the console of TTY when the error occurred.

**Action:**

Check the MSDL300 message to find out the reason.

Alternatively, display the status of the MSDL, which also indicates the cause of the problem, with the **STAT MSDL x** command and check the information to find the cause of the fatal error.

Allow the system to attempt recovery. If this fails, either by reaching a threshold or detecting self-test failure, place the MSDL in the manually disabled state with the **DIS MSDL x** command and follow the steps in “Previously operating MSDL cards” on [page 420](#).

## SYSTEM DISABLED—RECOVERY THRESHOLD

**Cause:** The system attempted autorecovery of the MSDL card more than five times within 30 minutes and each time the card was disabled again. The system attempts to enable the card again at midnight unless you intervene.

**Action:**

Place the MSDL card in a manually disabled state with the **DIS MSDL x** command and follow the steps in “Previously operating MSDL cards” on [page 420](#).

---

# NT7D16 Data Access card

---

## Content list

The following are the topics in this section:

Introduction . . . . .	428
Features . . . . .	428
Controls and indicators . . . . .	429
Dialing operations . . . . .	430
Operating modes . . . . .	435
Keyboard dialing . . . . .	472
Hayes dialing . . . . .	485
Specifications . . . . .	497
System database requirements . . . . .	500
Power supply . . . . .	504
Installing the Data Access card . . . . .	505
Port configuration . . . . .	507
Cabling . . . . .	509
Backplane pinout and signaling . . . . .	514
Configuring the Data Access card . . . . .	517
Connecting Apple Macintosh to the DAC . . . . .	522
Upgrading systems . . . . .	522

## Introduction

The NT7D16 Data Access card (DAC) is a data interface card that integrates the functionality of the QPC723A RS-232 4-Port Interface Line card (RILC) and the QPC430 Asynchronous Interface Line card (AILC). This combination allows the NT7D16 DAC to work with the RS-232-C interface, the RS-422 interface, or both.

The DAC supports up to six ports, each capable of operating in RS-232-C or RS-422 mode. Each port supports its own parameters that, once configured and stored in the system database memory, are downloaded to the card.

You can install this card in any IPE slot.

## Features

Light Emitting Diodes (LEDs) indicate the status of the card, the call connection, and the mode (RS-232-C or RS-422) the DAC is operating in. A push-button toggle switch allows you to scan all six ports and monitor the activity on each port.

The DAC supports the following features:

- Asynchronous and full duplex operation
- Keyboard dialing
- Hayes dialing
- Data terminal equipment (DTE)/data communication equipment (DCE) mode selection
- Modem and gateway connectivity in DTE mode
- Terminal and host connectivity in DCE mode
- Forced or normal DTR
- Hotline
- Remote and local loopback testing
- Virtual leased line mode
- Inactivity timeout

- Wire test mode
- Self diagnostics
- Inbound modem pooling with any asynchronous modems
- Outbound modem pooling using “dumb” modems
- Outbound modem pooling using auto dialing modems

## Controls and indicators

The LEDs on the DAC faceplate indicate the status mode for each port. Figure 88 on [page 431](#) shows the NT7D16 DAC faceplate.

### Card status

The LED at the top of the faceplate is unlabeled. This LED is:

- off: if one or more ports are enabled
- on: if all ports are disabled

### Electronic Industries Association signal monitors

The six LEDs located below the card status LED are labeled SD, RD, DTR, DSR, DCD, and RI. They show the dynamic state of the associated Electronic Industries Association (EIA) control leads for a specific port (as shown by the display). When in RS-422 mode, only SD and RD are utilized. When in RS-232-C mode, the LED goes on to indicate that the signal is asserted on, or off to indicate that the signal is asserted off. When the LED is off, there is no active voltage on the signal lead.

### CONNECT

This lamp lights to indicate that a data call is established for the port displayed. A data call is connected when the data module-to-data module protocol messages are successfully exchanged between the two ends.

## Port mode

This lamp lights to indicate that the port indicated is in RS-422 mode. If the lamp is dark, the specified port is in RS-232-C mode.

## Port number

The number displayed specifies the port driving the EIA signal LEDs mentioned above. The push-button switch below the display allows you to rotate among the six ports to monitor the activity of any port. This display is also used to monitor several error conditions.

## Port select button

This push-button switch below the display is used to select which port is monitored.

## Wire test

These switches are used to select the wire test mode for each of the six ports.

## Dialing operations

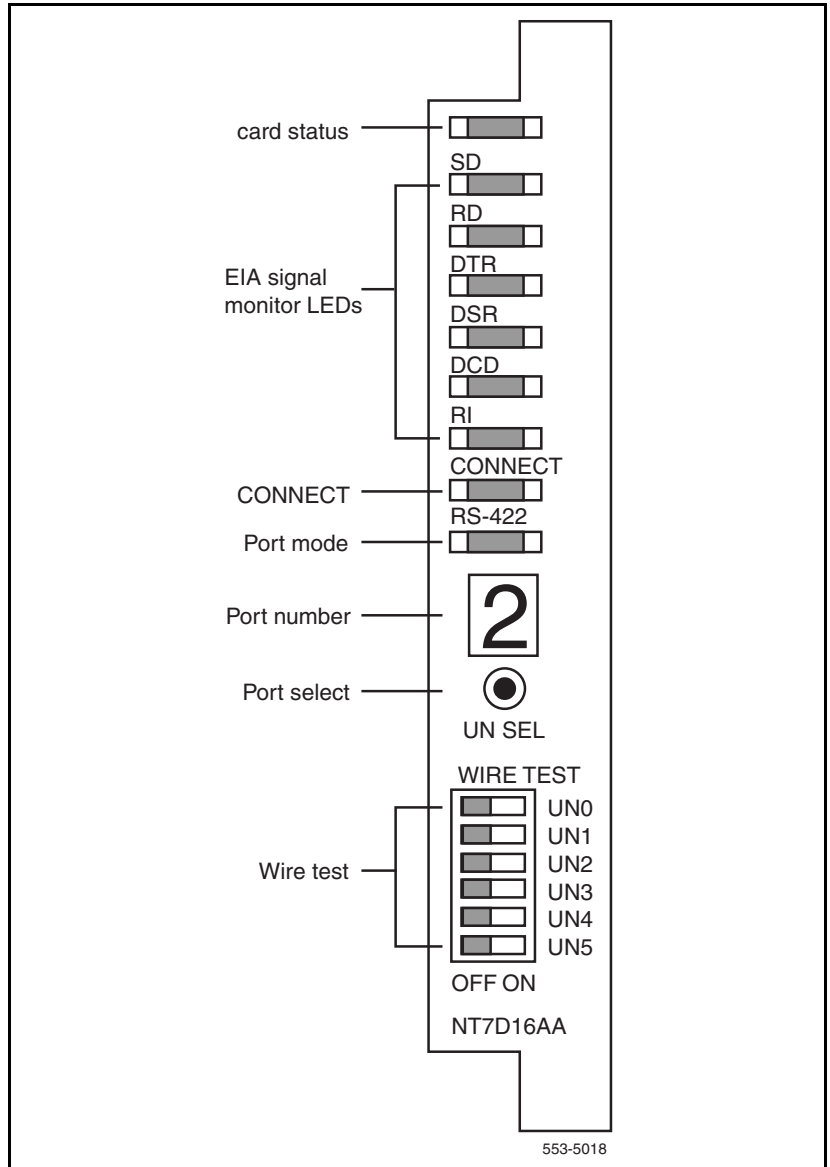
The DAC supports both keyboard and Hayes dialing sequences. The following discussion concerns features common to both dialing modes.

## Port firmware in idle state

The port firmware is considered idle when it is expecting one of the allowed autobaud characters. The idle state is identified by either of the following conditions:

- The last prompt received was RELEASED (keyboard dialing).
- The last prompt received was OK, NO CARRIER, or ERROR (Hayes dialing).

**Figure 88**  
**NT7D16 Data Access card faceplate**



## Call Set-up abort

The user may abandon the call during the dialogue phase using one of the following methods:

- **Terminal off-line** This method is useful for RS-232-C interface only. The equipment drops Data Terminal Ready (DTR) to indicate an idle connection. For example, if the equipment is turned off, the DAC interprets that signal as an idle connection.
- **Long break** The user sends a break (transmit line held in the OFF or SPACE state) for more than 1.2 seconds. The break is not transmitted to the far end. At the end of the long break, the DAC port initiates call disconnect. The AILU converts the dropping of DTR into a long break for the RS-422 interface. The long break feature can be disabled through the Modify menu on the DAC port.
- **Three short breaks** When the user equipment transmits three breaks to the far end, the DAC abandons the call. Note that the breaks must be spaced at least 10 msec apart, and all three must occur within 3 seconds.

## Make Port Busy on loss of DTR

This feature is implemented by means of the Make Set Busy (MSB) station feature. When this is activated, any attempt to reach the specified Data DN will result in a busy signal.

This application, which operates only in the RS-232-C mode, requires a non-standard RS-232-C interface. Only two of the possible sixteen RS-232-C modes can be used: Mode 8 (DCE, Host, Normal DTR, Manual dial), and Mode 12 (DCE, Terminal, Normal DTR, Manual dial). This feature is configured in the software, and is downloaded to the DAC.

A DTR timeout period is started whenever the DTR signal lead makes the transition to OFF. If DTR is returned to ON within the set time period (5 seconds), the DAC port operates as if this feature was not activated. If the DTR remains OFF beyond the 5 seconds, the system receives an MSB feature key message. The DAC sends another MSB message when the DTR returns to ON, and the port is able to receive inbound calls.



**Note:** If this feature is active, and the port is connected to a DTE that holds DTR OFF when idle, the port will be permanently busied out to inbound calls following the DTR timeout period.

## Inactivity timeout

Once a successful data call is completed, the user's activity is monitored. If no activity occurs within the amount of time configured in the downloaded parameters, the DAC releases the call. Three minutes before the inactivity timeout takes place, the DAC sends a warning message to the near-end equipment if terminal mode is selected.

## Wire test mode

The DAC allows for the EIA signaling leads to be tested to facilitate installation and troubleshooting. This feature can be invoked through the service change downloaded parameters, or by setting the appropriate front panel switch. Wire test mode only operates when the port is idle. The leads are cycled ON and OFF in 0.5 second periods (ON for 0.5 seconds, OFF for 0.5 seconds) for the number of cycles shown in Table 156 on [page 433](#). The lead status can be monitored by the front panel LEDs. The test will be run indefinitely until the front panel switch is turned off, and the software wire test parameters are disabled.

**Note:** For the most accurate results, be sure no equipment is connected to the EIA leads.

**Table 156**  
**Wire test signal leads cycle counts**

Label	EIA Signal Lead description	Pin	Cycle count	
			RS-232-C	RS-422
TxD	Transmit	2	1	1
RxD	Receive	3	2	2

**Note:** The CTS signal is not included in the faceplate LED. Therefore, a 1.5-second delay will occur between the RxD lamp going on, and the DSR lamp going on.

**Table 156**  
**Wire test signal leads cycle counts**

Label	EIA Signal Lead description	Pin	Cycle count	
			RS-232-C	RS-422
CTS	Clear To Send	5	3	—
DSR	Data Set Ready	6	4	—
DCD	Carrier Detect	8	5	—
DTR	Data Terminal Ready	20	6	—
RI	Ring Indicator	22	7	—

**Note:** The CTS signal is not included in the faceplate LED. Therefore, a 1.5-second delay will occur between the RxD lamp going on, and the DSR lamp going on.

## Independent storage of dialing parameters

Two dialing parameters, DCD control, and Answer mode, can be modified by both keyboard and Hayes dialing commands.

The Hayes dialing mode also allows the user to modify the Input echo control, and Prompt/Result codes transmit control. With keyboard dialing, the Input echo control and Prompt/Response codes control are determined by the downloaded parameters. They cannot be altered through dialing commands.

The DAC maintains separate buffers for keyboard and Hayes dialing modes. Changes made to a given parameter in one mode do not affect that parameter in the other mode. When a dialing mode is selected, the DAC copies the corresponding dialing parameters into the active buffer. This buffer controls the call processing.

If the DAC receives an incoming call while idle, the most recent dialing mode is used to answer the call.

### User input

User input may include either upper or lower case ASCII characters.

All entries are accumulated in an input record. This record is completed with a Terminator character. For keyboard dialing, this character is always <CR>; for Hayes dialing, it can be user defined (but default to <CR>). The entries are not processed until the Terminator character is received.

The input record is limited to 43 characters, including the Terminator, but excluding any ignored space characters.

The record can be edited by using the backspace and escape characters.

## Operating modes

There are sixteen possible RS-232-C operating modes with three basic common modes of operation which correspond to three types of equipment connected to the DAC. The three modes are: modem, terminal, and host. Host mode is a subset of the terminal mode, which only suppresses the prompts at the terminal.

The fourth mode, gateway, is a subset of the modem mode and is not normally used. This mode is useful if the attached modems do not have Ring Indicator lead. The application used is inbound modem pooling.

The different modes enable the DAC to connect to different types of devices such as modems (modes 0, 1, 2, and 3), gateways (modes 4, 5, 6, and 7), hosts (modes 8, 9, 10, and 11), and terminals (modes 12, 13, 14, and 15). After selecting the appropriate group (that is, modem, gateway, host, or terminal), the installer should study the four different modes in that group to make the proper selection. See Table 157.

**Table 157**  
**DAC mode of operation selection (Part 1 of 5)**

Service changeable downloadable parameters (LD 11)					
Operation mode	Modem/ Gateway/ Host/KBD	Forced DTR*	Hotline	Type of device to be connected	Group selection
DEM	PRM	DTR	HOT		
0 (DTE)	OFF "Host On" (Ring Indicator — RI)	OFF Not Forced	OFF Not Hotline	Modem Pool inbound and outbound (similar to Synchronous / Asynchronous Data Module (SADM) in inbound) MSB by RI	Modes 0, 1, 2, and 3 are for RS232 modem connectivity
1 (DTE)	OFF "Host On" (RI)	OFF Not Forced	ON Hotline	Modem Pool inbound only (Hotline by RI- similar to SADM)	

\* Not prompted for Type = R422. Defaults for Type = R422: DEM = DCE and DTR = OFF.

**Table 157**  
**DAC mode of operation selection (Part 2 of 5)**

<b>Service changeable downloadable parameters (LD 11)</b>					
<b>Operation mode</b>	<b>Modem/ Gateway/ Host/KBD</b>	<b>Forced DTR*</b>	<b>Hotline</b>	<b>Type of device to be connected</b>	<b>Group selection</b>
<b>DEM</b>	<b>PRM</b>	<b>DTR</b>	<b>HOT</b>		
2 (DTE)	OFF "Host On" (RI)	ON Forced	OFF Not Hotline	Modem Pool inbound and outbound (for Hayes 1200 modem) MSB by RI	
3 (DTE)	OFF "Host On" (RI)	ON Forced	ON Hotline	Modem Pool inbound only (Hotline for Hayes 1200 modem only)	
4 (DTE)	ON "Keyboard Dialing (KBD) On" (No RI)	OFF Not Forced	OFF Not Hotline	Gateway inbound and outbound (DTR is OFF in idle state) MSB by Carrier Detect (DCD)	Modes 4, 5, 6, and 7 are for RS232 Gateway connectivity
5 (DTE)	ON "KBD On" (No RI)	OFF Not Forced	ON Hotline	Gateway inbound only (Hotline by DCD: ON for Hotline OFF for Virtual Leased Line (VLL)	
* Not prompted for Type = R422. Defaults for Type = R422: DEM = DCE and DTR = OFF.					

**Table 157**  
**DAC mode of operation selection (Part 3 of 5)**

Service changeable downloadable parameters (LD 11)					
Operation mode	Modem/ Gateway/ Host/KBD	Forced DTR*	Hotline	Type of device to be connected	Group selection
DEM	PRM	DTR	HOT		
6 (DTE)	ON "KBD On" (No RI)	ON Forced	OFF Not Hotline	Gateway inbound and outbound (DTR is on in idle state) MSB by DCD	
7 (DTE)	ON "KBD On" (No RI)	ON Forced	ON Hotline	Gateway inbound only (Hotline by DCD: ON for Hotline OFF for VLL) (DTR is ON in idle state)	
8 (DCE)	OFF "Host On" (prompts off)	OFF Not Forced	OFF Not Hotline	Outbound to Host (similar to Multi Channel Data System (MCDS)) Prompt PBDO = OFF/ON	Modes 8 and 9 are for RS422 Host connectivity
9 (DCE)	OFF "Host On" (prompts off)	OFF Not Forced	On Hotline	Host Hotline by DTR	
* Not prompted for Type = R422. Defaults for Type = R422: DEM = DCE and DTR = OFF.					

**Table 157**  
**DAC mode of operation selection (Part 4 of 5)**

<b>Service changeable downloadable parameters (LD 11)</b>					
<b>Operation mode</b>	<b>Modem/ Gateway/ Host/KBD</b>	<b>Forced DTR*</b>	<b>Hotline</b>	<b>Type of device to be connected</b>	<b>Group selection</b>
<b>DEM</b>	<b>PRM</b>	<b>DTR</b>	<b>HOT</b>		
10 (DCE)	OFF "Host On" (prompts off)	ON Forced	OFF Not Hotline	Host similar to MCDS but does not require DTR to be ON	Modes 8, 9, 10, and 11 are for RS232 Host connectivity
11 (DCE)	OFF "Host On" (prompts off)	ON Forced	On Hotline	Continuous Hotline mode when DTR is ON (VLL)	
12 (DCE)	ON "KBD On" (prompts on)	OFF Not Forced	OFF Not Hotline	Terminal similar to Asynchronous/ Synchronous Interface Module (ASIM) when set to Not Forced DTR and Not Hotline Prompt PBDO = OFF/ON	Modes 12 and 13 are for RS422 Terminal connectivity
13 (DCE)	ON "KBD On" (prompts on)	OFF Not Forced	On Hotline	Terminal similar to ASIM when set to Not Forced DTR and Hotline	
* Not prompted for Type = R422. Defaults for Type = R422: DEM = DCE and DTR = OFF.					

**Table 157**  
**DAC mode of operation selection (Part 5 of 5)**

Service changeable downloadable parameters (LD 11)					
Operation mode	Modem/ Gateway/ Host/KBD	Forced DTR*	Hotline	Type of device to be connected	Group selection
DEM	PRM	DTR	HOT		
14 (DCE)	ON "KBD On" (prompts on)	ON Forced	OFF Not Hotline	Terminal similar to ASIM when set to forced DTR and Not Hotline	Modes 12, 13, 14, and 15 are for RS232 Terminal connectivity (similar to ASIM)
15 (DCE)	ON "KBD On" (prompts on)	ON Forced	On Hotline	Continuous Hotline when DTR is ON	

\* Not prompted for Type = R422. Defaults for Type = R422: DEM = DCE and DTR = OFF.

### Selecting the proper mode for Modem connectivity

Select modes 0, 1, 2, and 3 when the DAC is connected to different types of modems for inbound and outbound modem pooling. In these modes, the DAC operates as a DTE, monitors the DSR, DCD, and RI control leads, and drives the DTR lead. No menus are given and no characters are echoed when DCD is OFF. All prompts and messages are enabled for inbound calls and disabled for outbound calls.

In modes 0 and 1, the DAC drives the DTR lead OFF when in the idle state, and ON when processing an incoming or outgoing call.

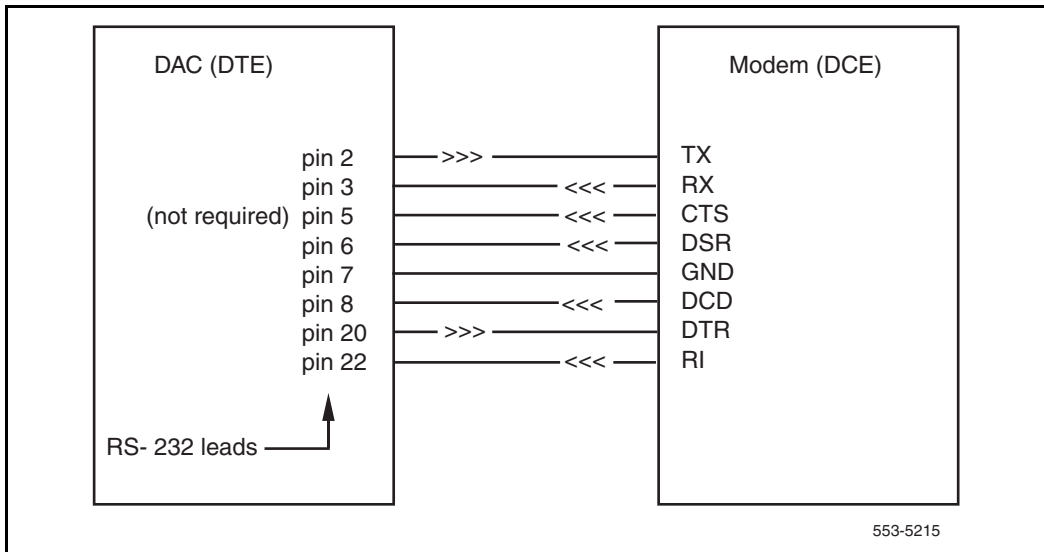
In modes 2 and 3, the DAC drives the DTR lead ON except when the call is being disconnected. At disconnect, DTR is dropped for 0.2 seconds and then returns to ON.



In the case of outbound modem pooling, the DAC answers the data call and drives the DTR lead ON (modes 0 and 1). Then the calling data module and the DAC form a transparent link between the calling DTE and the modem. The DTE user may then enter the appropriate commands to the modem for dialing a remote modem. When the call is established, the modem may cause the DAC to disconnect the call by dropping either DSR or DCD.

In the case of inbound modem pooling, the modem must drive the RI lead ON to activate the DAC. Then the DAC responds by driving the DTR lead ON and making the unit busy for outbound calls (modes 0 and 1). The modem is expected to turn DCD to ON within 35 seconds; otherwise, the call will be dropped by the DAC. If the modem turns DCD ON before the 35-second timeout, the DAC validates the incoming call and prepares to accept <CR> from the remote modem for autobaud. See Figure 89 on [page 442](#) for more details.

**Figure 89**  
**DAC to modem connectivity**



## Mode 0

This mode should be selected when the DAC is connected to a modem, except Hayes-1200, for inbound and outbound modem pooling (see modes 2 and 3 for Hayes-1200 modem). The modem used should have the following features:

**Auto-answer capability** This feature is required when the modem is used for inbound modem pooling. It allows the modem to drive the RI lead ON when ringing is present at its tip and ring. In addition, the modem should auto-answer after the first ringing cycle if the DTR lead is ON (most modems support this feature).

**Dynamic control of DCD** This feature must be supported by all modems to be connected to the DAC. It allows the modem to drive the DCD lead ON when the carrier is detected and OFF when the carrier is absent (most modems support this feature).

**Auto-dial capability** This feature is required when the modem is used for outbound modem pooling. It allows the modem to go off-hook and dial the remote number (such as Smartmodem Hayes-2400 or Bizcomp).

**Auto-reset capability** This feature is required when the modem is used for outbound modem pooling. The modem should execute auto-reset when the DTR lead goes OFF. As a result, the modem must reset all its internal parameters to the default values. This feature prevents the users of the modem pool from modifying the modem's default parameters to inappropriate values.

### **Configuring modems for mode 0**

To configure Hayes modem 2400, enter the following commands:

```
AT&D2&W
ATV1&W
ATQ&W
ATE1&W
ATSO= 1&W
AT&C1&S1&W
AT&J&W
ATB1&W
AT&D3&W
```

Since the default parameters are programmable using commands, there is no guarantee that users will not change them.

To configure Bizcomp 1200 modem, set the following parameters in LD11:

```
DEMDTE
PRMOFF
DTROFF
HOTOFF
```

- To configure MULTI MODEM 224E modem, set the configuration switches as follows:

switches 3 and 8 to DOWN position

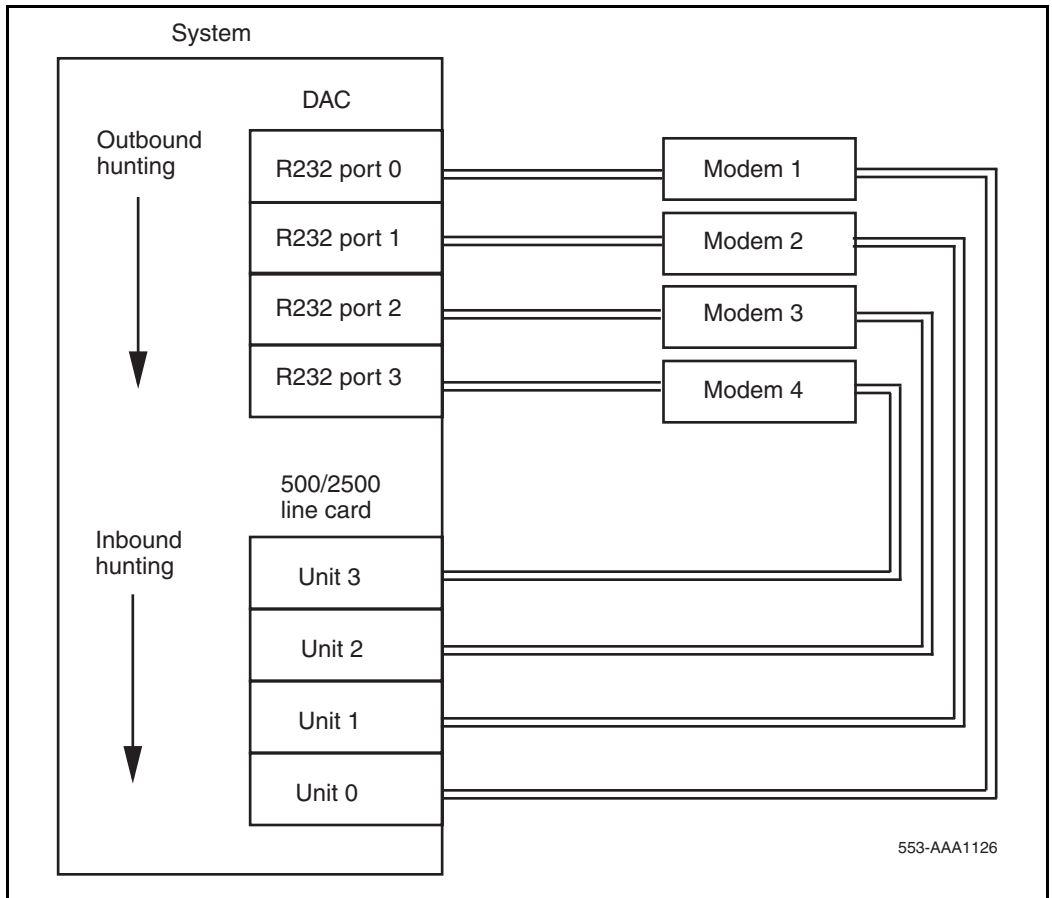
- all other switches to UP position. Switch 7 should be UP when using RJ-11 jack.

### **Programing DAC for mode 0 in service change LD11**

When used for inbound or outbound Modem Pool only, the DAC can be configured as R232 in LD11. When used for both inbound and outbound Modem Pool, the DAC must be configured as R232; station hunting for the outbound modem access should be in the opposite direction to the 500/2500 station hunting for the inbound modem access. See Figure 90 on [page 445](#) for more details.

*Note:* If Call Detail Recording (CDR) is required, use separate outbound and inbound Modem Pools.

**Figure 90**  
**DAC to Modem Pool connectivity**



## Mode 1

This mode should be selected when the DAC is connected to an auto-answer modem for inbound Hotline operation. In this mode, the DAC automatically executes Hotline operation when RI is driven ON by the modem. The modem used should have the following features:

**Auto-answer capability** This feature is required when the modem is used for inbound modem pooling. It allows the modem to drive the RI lead ON when ringing is present at its tip and ring. In addition, the modem should auto-answer after the first ringing cycle if the DTR lead is ON (most modems support this feature).

**Dynamic control of DCD** This feature must be supported by all modems to be connected to the DAC. It allows the modem to drive the DCD lead ON when the carrier is detected and OFF when the carrier is absent (most modems support this feature).

The baud rate of the Hotline call is determined by switches 6 and 8, and the system should be programmed to allow inbound modem calls only.

### Configuring modems for mode 1

Most dumb modems can be configured for this mode. The modem must be able to auto-answer and have dynamic control of DCD as described in mode 0. Smart modems can also be used if set to the dumb mode of operation. Hayes 2400, Bizcomp 1200, and MULTI MODEM 224E can be used when set up as follows:

- For Hayes 2400, the dumb-mode-strap should be moved to the dumb-position (see Hayes manual).
- For Bizcomp 1200 modem, set the following parameters in LD11:

```
DEMDTE  
PRMOFF  
DTROFF  
HOTON
```

Hayes 1200 cannot be used in this mode when the default parameters are selected (see mode 3).

### **Programing DAC for mode 1 in service change LD11**

The DAC must be configured as R232 (the Autodial feature key is used for this mode). The DAC must not be configured as an Asynchronous Data Module (ADM) trunk.

## **Mode 2**

This mode should be selected when the DAC is connected to a Hayes-1200 modem for inbound and outbound modem pooling. This mode is created specially to resolve some problems that were encountered with this modem, namely, the auto-reset implementation. When this modem is operating in the auto-reset mode, it drives both RI and DCD ON as long as DTR is OFF. This problem was resolved by driving DTR ON in the idle state, and OFF for 0.2 seconds, and then ON when an established call is dropped. The DAC also ignores the status of RI and DCD for approximately 2 seconds after a call is released to avoid false inbound call initiation.

### **Configuring Hayes 1200 for mode 2**

To configure this modem, set the following parameters in LD11:

DEMDTE  
PRMOFF  
DTRON  
HOTOFF

To configure this modem, set the configuration switches as follows:

- switches 3, 8, and 10 to DOWN position
- all other switches to UP position. Switch 7 should be UP when using RJ-11 jack.

### **Programing DAC for mode 2 in service change LD11**

When used for inbound or outbound Modem Pool only, the DAC can be configured as R232 in LD11. When used for both inbound and outbound Modem Pool, the DAC must be configured as R232. When the DAC is programmed as station hunting, outbound modem access should be in the opposite direction to the 500/2500 station hunting for the inbound modem access.

*Note:* If Call Detail Recording (CDR) is required, use separate outbound and inbound Modem Pools.

## Mode 3

This mode should be selected when the DAC is connected to a Hayes-1200 modem for inbound Hotline operation. It is recommended that mode 1 be used for inbound Hotline operations if some other modem is available. However, if only Hayes-1200 modems are available, then this mode could be used as a last resort.

### Configuring Hayes 1200 for mode 3

For Hayes 1200 modem, set the following parameters in LD11:

```
DEMDTE
PRMOFF
DTRON
HOTON
```

To configure this modem, set the configuration switches as follows:

- all switches to UP position, except for switch 4. Switch 7 should be UP when using RJ-11 jack.

### Programing DAC for mode 3 in service change LD11

The DAC must be configured as R232 (the Autodial feature is used for this mode). The DAC must not be configured as an ADM trunk.

## Selecting the proper mode for Gateway connectivity

Select modes 4, 5, 6, and 7 when the DAC is connected to different types of gateways for inbound and outbound operations. The term gateway refers to any equipment that has the following characteristics:

- The equipment must be a DCE.
- The equipment does not drive RI lead (optional, the DAC ignores this lead).
- The equipment must drive DCD lead dynamically.
- The equipment drives DSR lead (optional).



- The equipment can monitor the DTR lead (optional, depending on the mode selected).

In modes 4, 5, 6, and 7, the DAC:

- operates as a DTE
- monitors the DSR
- monitors DCD control leads
- drives the DTR lead

The RI lead is ignored. No menus or prompts are given when DCD is OFF. All prompts and messages are enabled for inbound calls and disabled for outbound calls. See Figure 91 on [page 450](#) for more details.

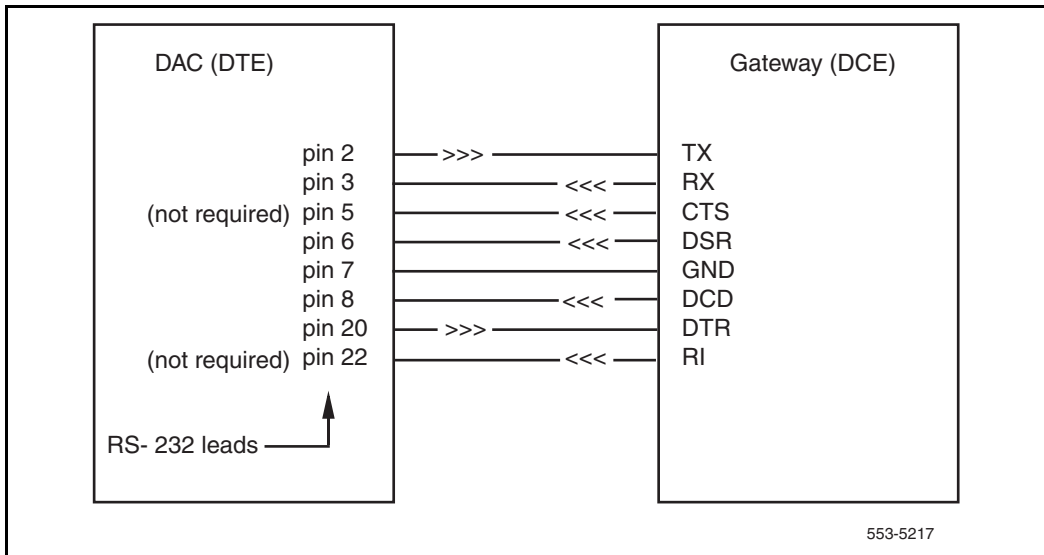
In modes 4 and 5, the DAC drives the DTR lead OFF in the idle state, and ON when processing an incoming or outgoing call.

In modes 6 and 7, the DAC drives the DTR lead ON except when the call is being disconnected. At disconnect, DTR is dropped for 0.2 seconds and then returns to ON.

With outbound gateway access, the DAC answers the data call and drives the DTR lead ON (modes 4 and 5; in modes 6 and 7, DTR is already ON). Then the calling data module and the DAC form a transparent link between the calling Data Module (DM) and the gateway. The DM user may then enter the appropriate commands to the gateway to establish a data call. The DAC expects the gateway to drive DCD ON (modes 4 and 5 only) within 35 seconds. If the gateway fails to do so, the DAC turns DTR OFF and drops the call. When the call is established, the gateway may cause the DAC to disconnect the call by dropping either DSR or DCD.

For inbound gateway access, the gateway must drive the DCD lead ON to activate the DAC. When the DAC receives this signal, it drives the DTR lead ON, makes the unit busy for outbound calls (modes 4 and 5; in modes 6 and 7, DTR is already ON), and prepares to accept <CR> for autobaud. The DAC expects DCD to remain ON for as long as the data call is established.

**Figure 91**  
**DAC to Gateway connectivity**



## Mode 4

This mode should be selected when the DAC is connected to a gateway for inbound and outbound operation. The characteristics of the gateways to be used with this mode are:

**Auto-answer capability** This feature is required when the gateway is used for inbound operation. It allows the gateway to drive the DCD lead ON when the inbound data call is pending. In addition, the gateway should auto-answer when the DTR lead is ON.

**Dynamic control of DCD** This feature must be supported by all gateways to be connected to the DAC. It allows the gateway to drive the DCD lead ON when the data call is established, and OFF when the data call is disconnected.

In the inbound operation, the DAC drives the DTR lead OFF until the gateway drives the DCD lead ON. Then, the DAC drives DTR ON and makes that unit busy for any outbound calls. After that, the user of the gateway may enter the proper commands to establish a local data call to any DM.

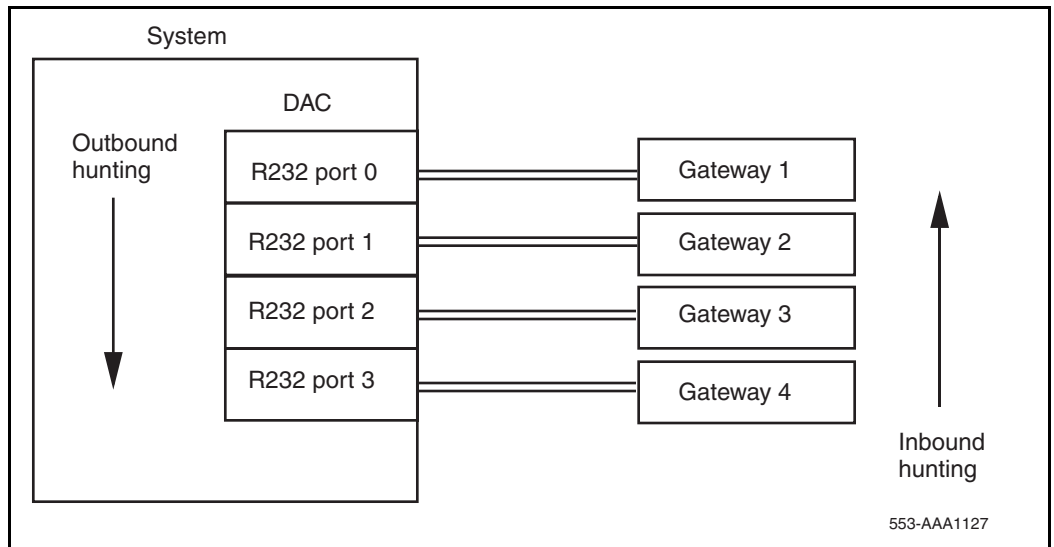
In the outbound operation, the DAC drives the DTR lead OFF until another DM calls it for outbound accessing. The DAC answers the data call and drives the DTR lead ON. The calling DM is then transparently connected to the gateway. The DAC requires the gateway to drive the DCD lead to ON within 35 seconds after the outbound call is connected. Call disconnection may be initiated by dropping DCD (or DSR) from ON to OFF.

**Programing DAC for mode 4 in service change LD 11**

When used for inbound or outbound gateway access, the DAC can be configured as R232 in LD 11. When used for both inbound and outbound gateway access, the DAC must be configured as R232. When the DAC is programmed as station hunting, outbound gateway access should be in the opposite direction to the hunting for inbound gateway access. See Figure 92 for more details.

*Note:* If CDR is required, use separate outbound and inbound gateway access.

**Figure 92**  
**DAC to Gateway—Inbound/Outbound connectivity**



## Mode 5

This mode should be selected when the DAC is connected to an auto-answer gateway for inbound Hotline operation. In this mode, the DAC automatically executes Hotline operation when DCD is driven ON by the gateway. If the DM being called by the Hotline operation is busy or not answering, the DAC will place repeated Hotline calls as long as the DCD lead is ON until the called unit answers. The gateway used in this mode should have the following features:

**Auto-answer capability** This feature is required when the gateway is used for inbound operation. It allows the gateway to drive the DCD lead ON when the inbound data call is pending. In addition, the gateway should auto-answer when the DTR lead is ON.

**Dynamic control of DCD** This feature must be supported by all gateways to be connected to the DAC. It allows the gateway to drive the DCD lead ON when the data call is established, and OFF when the data call is disconnected.

The baud rate of the Hotline call is determined by the AUTB and BAUD parameters in LD 11. The system should be programmed to allow inbound modem calls only.

### **Programing DAC for mode 5 in service change LD 11**

The DAC must be configured as R232 (the Autodial feature is used for this mode). The DAC must not be configured as an ADM trunk.

## Mode 6

This mode should be selected when the DAC is connected to a gateway that requires DTR to be ON always except during call disconnection. In this mode, the DAC can be used for both inbound and outbound operations. The operation of this mode is similar to mode 4 except for the following:

- The DTR lead is ON in the idle state.
- The DTR lead will be dropped OFF for 0.2 seconds when an established call is disconnected.

### **Programing DAC for mode 6 in service change LD 11**

When used for inbound or outbound gateway access, the DAC can be configured as R232 in LD 11. When used for both inbound and outbound gateway access, the DAC must be configured as R232. When the DAC is programmed as station hunting, outbound gateway access should be in the opposite direction to the hunting for inbound gateway access. See Figure 92 on [page 451](#) for more details.

*Note:* If CDR is required, use separate outbound and inbound gateway access.

## **Mode 7**

This mode should be selected when the DAC is connected to a gateway for inbound Hotline operation. The operation of this mode is similar to mode 5 except for the following:

- The DTR lead is ON in the idle state.
- The DTR lead will be dropped OFF for 0.2 second when an established call is disconnected.

The baud rate of inbound Hotline calls is determined by programmable database. The system should be programmed to allow inbound calls only on the DAC unit.

### **Programing DAC for mode 7 in service change LD 11**

The DAC must be configured as R232 (the Autodial feature is used for this mode). The DAC must not be configured as an ADM trunk.

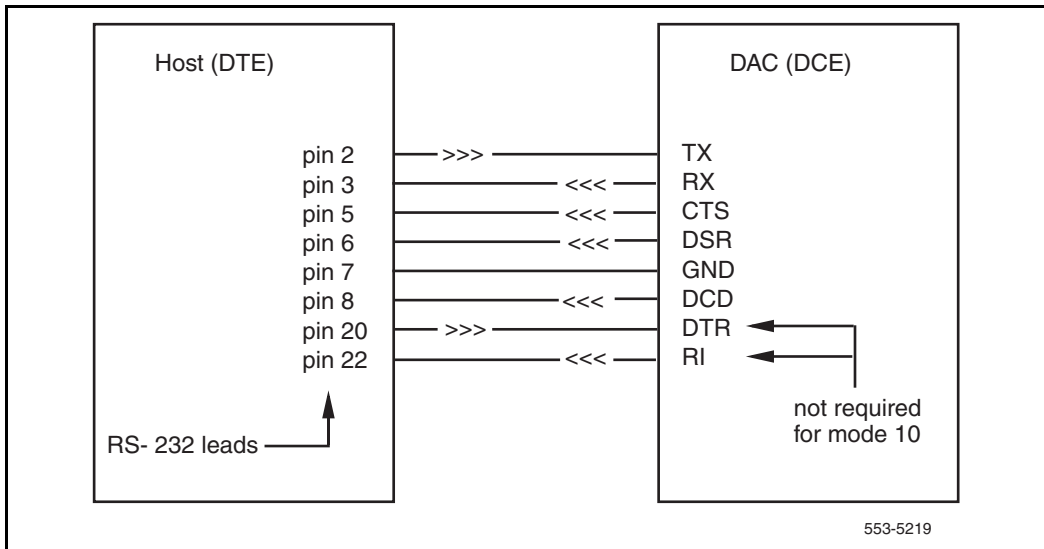
## **Selecting the proper mode for Host connectivity**

Select modes 8, 9, 10, and 11 when the DAC is connected to different types of hosts (DTE). In these modes, the DAC operates as a DCE and drives DSR, DCD, and RI control leads (see Figure 93 on [page 454](#)). CTS, DSR, and DCD are driven OFF in the idle state.

The DAC will not send any menu or prompt to the host, nor will it echo any command sent from the host. The CTS, DSR, and DCD will be driven ON until the call is released. An incoming call to the DAC causes the RI lead to

go ON for 2 seconds and then OFF for 4 seconds until the call is answered by the host. When the host turns DTR ON, the DAC answers the call. If DM-to-DM protocol exchange is successful, the DAC drives CTS, DSR, and DCD ON. If DTR was already ON, the DAC does not drive RI ON.

**Figure 93**  
**DAC to Host connectivity**



## Mode 8

This mode should be selected when the DAC is connected to a host for host accessing. In this mode, the DAC operates in a similar manner to the MCDS. The hosts used with this mode should have the following characteristics:

**Auto-answer capability** The host should be capable of monitoring the RI lead for detection of incoming calls. When RI is turned ON by the DAC, the host responds by driving DTR ON, which forces the DAC to answer the incoming call. If the host drives the DTR lead ON all the time, incoming calls will always be immediately answered and the RI lead will not be turned ON by the DAC. If DM-to-DM protocol exchange is successful, the DAC drives CTS, DSR, and DCD ON.

**Dynamic control of DTR** This feature is required only if the host must be capable of releasing an established call. The host should be able to drop an established data call by driving DTR OFF for more than 100 ms.

*Note:* If the PBDO parameter in LD 11 is ON, then Make Set Busy will be activated when DTR is driven OFF for more than five seconds.

In this mode, the DAC will not send any menus or prompts to the host. However, the host can still originate an outgoing call by blind-dialing (sending commands to the DAC without receiving echoes).

**Programing DAC for mode 8 in service change LD 11** When used for inbound or outbound host access, the DAC can be configured as R232 or R422 in LD 11. When used for both inbound and outbound host access, the DAC must be configured as R232 or R422. When the DAC is programmed as station hunting, outbound host access should be in the opposite direction to the hunting for inbound host access.

*Note:* If CDR is required, use separate outbound and inbound host access.

## Mode 9

This mode should be selected when the DAC is connected to a host and Hotline call origination is required. In this mode, the host will be able to Hotline to a specific data unit by simply driving the DTR lead ON. The transition of DTR from OFF to ON causes the DAC to Hotline to the Autodial DN. The hosts used with this mode should have the following characteristics.

**Dynamic control of DTR for call origination** The host should be capable of driving the DTR lead from OFF to ON to initiate the Hotline call. If the host always drives the DTR lead ON (not capable of dynamic control), mode 11 should be used.

**Dynamic control of DTR for releasing established calls** This feature is required only if it is required that the host be capable of releasing an established call. The host should be able to drop an established data call by driving DTR OFF for more than 100 ms.

### **Programing DAC for mode 9 in service change LD 11**

The DAC must be configured as R232 or R422 (the Autodial feature is used for this mode). The DAC must not be configured as an ADM trunk.

## **Mode 10**

This mode should be selected when the DAC is connected to a host for inbound host accessing. The host in this mode is not required to monitor RI or drive DTR. This mode is similar to mode 8, except for the following:

- The status of DTR lead is assumed to be always ON, even when the actual condition of that lead is OFF (forced-DTR). The DAC always answers an incoming call regardless of the status of DTR.
- The host cannot release an established data call by driving DTR OFF. As a result, the host cannot initiate call release except with a long break or three short breaks.

In this mode, the DAC does not send any menus or prompts to the host. However, the host can still originate an outgoing call by blind-dialing (sending commands to the DAC without receiving echoes).

### **Programing DAC for mode 10 in service change LD 11**

When used for inbound or outbound host access, the DAC can be configured as R232 in LD 11. When used for both inbound and outbound host access, the DAC must be configured as R232. When the DAC is programmed as station hunting, outbound host access should be in the opposite direction to the hunting for inbound host access.

*Note:* If CDR is required, use separate outbound and inbound gateway access.

## **Mode 11**

This mode provides a “virtual leased line” and the meaning of the Forced DTR switch is re-defined. The operation is similar to having a leased line feature, where the connection between two extensions is always established. The DAC does not send any menus or prompts to the host. The baud rate of the Hotline call is determined by switches 6, 7, and 8.



This mode should be selected when the DAC is connected to a host and continuous Hotline operation is required. In this mode, the DAC repeatedly tries to Hotline to the Autodial DN as long as DTR is ON. When the DAC tries to Hotline to a busy Data Module, it activates Ring Again and the connection is established as soon as the called unit is free. After establishing the data call, if the called unit releases the call for any reason, the DAC will automatically try to Hotline again to reestablish the call.

If the data unit being called does not answer the Hotline call, the DAC tries to place another Hotline call once every 40 seconds until the called unit answers. This mode is recommended only when a permanent connection between a host and another data unit is required.

### **Programing DAC for mode 11 in service change LD 11**

The DAC must be configured as R232 (the Autodial feature is used for this mode). The DAC must not be configured as an ADM trunk.

## **Selecting the proper mode for Terminal connectivity**

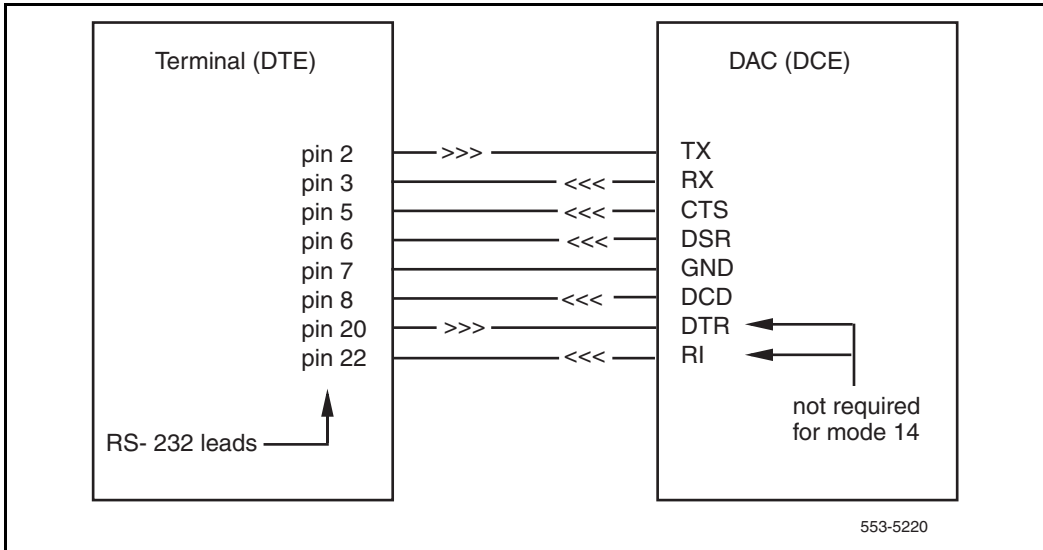
Select modes 12, 13, 14, and 15 when the DAC is connected to different types of terminals. In these modes, the DAC operates as a DCE, drives DSR, DCD, and RI control leads, and monitors DTR lead in modes 12, 13, and 15 (see Figure 94 on [page 458](#)). DTR is ignored in mode 14. All the menus and prompts are sent to the terminals and all the commands from the terminals are echoed. CTS, DSR, and DCD are driven OFF during the idle state (data call is not established).

When the call is released, DSR and DCD are turned OFF for 200 ms. The RI lead is controlled only in modes 12, 13, and 15, and is driven OFF in the idle and connect states. An incoming call to the DAC causes the RI lead to go ON for 2 seconds and then OFF for 4 seconds until the call is answered by the terminal. When the terminal turns DTR ON, the DAC answers the call.

## **Mode 12**

This mode should be selected when the DAC is connected to a terminal (DTE) for inbound and outbound data calls. This mode is similar to the operation of the ASIM when set to not-forced-DTR and not-Hotline. In this mode, call origination and auto-answer will not be executed by the DAC,

**Figure 94**  
**DAC to Terminal connectivity**



unless the DTR lead is driven ON by the terminal. Any terminal that drives the DTR lead ON can be used with this mode (such as VT100 or VT102).

The DAC drives CTS, DSR, and DCD ON, except when a call is dropped or when control—Z is entered during the idle state. In this case, the DAC drives those leads OFF for 0.2 seconds and then ON. When the DTR lead is driven OFF by the terminal, the DAC does not execute autobaud, nor will it respond to any command.

**Note:** If the PBDO parameter in LD 11 is ON, then Make Set Busy will be activated when DTR is driven OFF for more than five seconds.

**Programing DAC for mode 12 in service change LD 11**

The DAC must be configured as R232 or R422 since Autodial, Speed Call, and Display commands are likely to be used.

## Mode 13

This mode should be selected when the DAC is connected to a terminal (DTE) and Hotline call origination is required. This mode is similar to the operation of the ASIM when set to not-forced-DTR and Hotline. In this mode, the terminal is able to Hotline to a specific data unit by driving the DTR lead ON. The transition of DTR from OFF to ON causes the DAC to Hotline to the Autodial DN. Any terminal that drives DTR lead ON can be used with this mode (such as VT100 or VT102).

The DAC drives CTS, DSR, and DCD ON, except when a call is dropped. In this case, the DAC drives those leads OFF for 0.2 second and then ON. The baud rate of the Hotline call is determined by the AUTB and BAUD parameters in LD 11.

### Programing DAC for mode 13 in service change LD11

The DAC must be configured as R232 or R422 since Autodial, Speed Call, and Display commands are likely to be used.

## Mode 14

This mode should be selected when the DAC is connected to a terminal (DTE) for inbound and outbound data calls. This mode is similar to the operation of the ASIM when set to forced-DTR and not-Hotline. The terminal used with this mode is not required to drive the DTR lead. This mode of operation is similar to mode 12, except for the following:

- The status of DTR lead is assumed to be always ON, even when the actual condition of that lead is OFF (forced-DTR). The DAC always answers an incoming call regardless of the DTR status.
- The terminal cannot release an established data call by driving DTR OFF. As a result, the terminal cannot initiate call release except with a long break or three short breaks.

### Programing DAC for mode 14 in service change LD 11

The DAC must be configured as R232 since Autodial, Speed Call, and Display commands are likely to be used.

## Mode 15

This mode provides a “virtual leased line” and the meaning of the “Forced DTR” switch is re-defined.

This mode should be selected when the DAC is connected to a terminal (DTE) and continuous Hotline call origination is required. In this mode, the DAC repeatedly tries to Hotline to the Autodial DN as long as DTR is ON. This operation is similar to having a leased line feature, where the connection between two extensions is always established. When the DAC tries to Hotline to a busy Data Module, it activates Ring Again and the connection is established as soon as the called unit is free. After establishing the data call, if the called unit releases the call for any reason, the DAC automatically tries to Hotline again to reestablish the call.

If the data unit being called does not answer the Hotline call, the DAC tries to place another Hotline call once every 40 seconds until the called unit answers. This mode is recommended only when a permanent connection between a terminal and another data unit is required. The baud rate of the Hotline call is determined by the AUTB and BAUD parameters in LD 11. The status of CTS, DSR, and DCD is controlled in a similar manner as described in mode 13.

### Programing DAC for mode 15 in service change LD 11

The DAC must be configured as R232 since Autodial, Speed Call, and Display commands are likely to be used.

## Mode selection baud rates

The AUTB and BAUD parameters in LD 11 provide two functions for calls originated from a DAC:

- Provide a way to select a baud rate of a Hotline call. The DAC starts the Hotline operation without receiving a <CR> for autobaud.
- Set the DAC to operate at a fixed baud rate. The DAC does not return the menu or Hotline unless a <CR> is received at the selected baud rate. Normally the DAC should be selected to operate at autobaud.

*Note:* If AUTB is set to ON, the BAUD parameter is not prompted. If AUTB is set to OFF, you may select a fixed baud rate in response to the prompt BAUD.

When the DAC receives a call, it adapts to the caller's baud rate.

See Table 158 for connect and disconnect protocol.

**Table 158**  
**Connect and disconnect protocol (Part 1 of 12)**

Mode of operation	Interface application	Comments
Mode 0	<p>Inbound and Outbound modem pools</p> <p>For inbound modem pools, most dumb modems may be used.</p> <p>For outbound modem pools, only smart modems (auto-dialer) may be used.</p>	<p>Outbound modem pooling:</p> <p>Modem sends ring/no ring cycle (2 seconds ON, 4 seconds OFF) to initiate connection.</p> <p>DAC responds by driving DTR ON within the first ring cycle.</p> <p>Modem responds by answering the incoming call and driving DCD ON within 35 seconds.</p> <p>If modem does not drive DCD ON within 35 seconds, the DAC drops DTR and goes idle.</p> <p>Remote DTE sends &lt;CR&gt; to the DAC. The DAC autobauds and sends initial prompt.</p>

**Table 158**  
**Connect and disconnect protocol (Part 2 of 12)**

Mode of operation	Interface application	Comments
		<p><b>Outbound modem pooling:</b></p> <p>Local DM user calls to the outbound modem access number.</p> <p>DAC answers the outbound call and drives DTR ON.</p> <p>Modem receives DTR and prepares to receive commands.</p> <p>Local DM user enters the proper commands for calling the remote modem.</p> <p>Remote modem answers; data call established.</p> <p><b>Call disconnection (DAC):</b></p> <p>DAC drops DTR if the local DM user drops the call. The modem must drop DCD.</p> <p>DAC drops DTR if the remote modem sends a long break or three short breaks. The modem must drop DCD.</p> <p><b>Call disconnection (modem):</b></p> <p>Modem drops DCD (DCD OFF for 100 ms or more). The DAC drops DTR and disconnects the local call.</p> <p>Modem drops DSR (DSR OFF for 100 ms or more). The DAC drops DTR and disconnects the local call.</p>

**Table 158**  
**Connect and disconnect protocol (Part 3 of 12)**

<b>Mode of operation</b>	<b>Interface application</b>	<b>Comments</b>
Mode 1	<p>Inbound Hotline modem pools</p> <p>Most dumb modems can be used for this application.</p>	<p><b>Inbound Hotline modem pooling:</b></p> <p>Modem sends ring/no ring cycle (2 seconds ON, 4 seconds OFF) to initiate connection.</p> <p>DAC responds by trying to establish a Hotline call to a specific Data Module (Autodial).</p> <p>When Data Module answers, then and only then, the DAC turns DTR ON.</p> <p>Modem should answer the incoming call when DTR goes ON and should turn DCD ON within 35 seconds; otherwise the DAC disconnects the call.</p> <p><b>Call disconnection:</b></p> <p>Disconnection is the same as mode 0.</p>
Mode 2	<p>Inbound and Outbound modem pools (with forced DTR)</p> <p>Use this mode with Hayes 1200 modem.</p>	<p><b>Inbound and Outbound modem pooling:</b></p> <p>The DAC operation is identical to mode 0 except that DTR is always forced ON (except during disconnect).</p> <p><b>Call disconnection:</b></p> <p>Disconnection is identical to mode 0 except:</p> <ul style="list-style-type: none"> <li>—When a call is released, the DAC turns DTR OFF for 0.2 second and then ON. DTR stays ON until the next call release.</li> <li>—The DAC ignores RI and DCD for about 2 seconds after releasing a call. This avoids problems with the Hayes 1200 modem.</li> </ul>

**Table 158**  
**Connect and disconnect protocol (Part 4 of 12)**

Mode of operation	Interface application	Comments
Mode 3	Inbound Hotline modem pools (with forced DTR)  Use this mode with Hayes 1200 modem.	<p><b>Inbound Hotline modem pooling:</b></p> <p>The DAC operation is identical to mode 1 except that DTR is always forced ON (except during disconnect).</p> <p><b>Call disconnection:</b></p> <p>Disconnection is identical to mode 2.</p>
Mode 4	Inbound and Outbound Gateway access	<p><b>Inbound Gateway connection protocol:</b></p> <p>Gateway raises DCD to initiate connection.</p> <p>DAC responds by driving DTR ON.</p> <p>Gateway does not have to turn DSR ON. However, toggling DSR or DCD from ON to OFF causes the DAC to disconnect the call.</p> <p>Gateway user sends &lt;CR&gt; to the DAC.</p> <p>DAC autobauds and sends the initial prompt to the Gateway.</p> <p><b>Outbound Gateway connection protocol:</b></p> <p>Local DM user calls the DAC that is connected to a Gateway.</p> <p>DAC answers the data call and drives DTR ON.</p> <p>Gateway receives DTR and prepares to receive commands.</p> <p>Local DM user is now transparently connected to the Gateway.</p> <p>Gateway is expected to drive DCD ON within 35 seconds. If the Gateway fails to do so, the DAC drops DTR and the call.</p>



**Table 158**  
**Connect and disconnect protocol (Part 5 of 12)**

Mode of operation	Interface application	Comments
		<p><b>Call disconnection (DAC):</b></p> <p>DAC drops DTR if the local DM user drops the call. The Gateway must drop DCD.</p> <p>DAC drops DTR if the DAC receives a long break or three short breaks. The Gateway must drop DCD.</p> <p><b>Call disconnection (Gateway):</b></p> <p>Gateway drops DCD (DCD OFF for 100 ms or more). The DAC drops DTR and disconnects the local call.</p> <p>Gateway drops DSR (DSR OFF for 100 ms or more). The DAC drops DTR and disconnects the local call.</p>
Mode 5	Inbound Hotline Gateway access	<p><b>Inbound Hotline Gateway protocol:</b></p> <p>Gateway raises DCD to initiate connection.</p> <p>DAC responds by trying to establish a Hotline call to a specific Data Module (Autodial).</p> <p>When Data Module answers, then and only then, the DAC turns DTR ON.</p> <p>Gateway does not have to turn DSR ON. However, toggling DSR or DCD from ON to OFF causes the DAC to drop the call.</p> <p>Gateway is not transparently linked to the equipment connection to the DM.</p> <p><b>Call disconnection:</b></p> <p>Disconnection is identical to mode 4.</p>

**Table 158**  
**Connect and disconnect protocol (Part 6 of 12)**

<b>Mode of operation</b>	<b>Interface application</b>	<b>Comments</b>
Mode 6	Inbound and Outbound Gateway access (with forced DTR)	<p><b>Inbound and Outbound Gateway protocol:</b></p> <p>The DAC operation is identical to mode 4 except that DTR is always forced ON (except during disconnect). The establishment of the outbound call does not require DCD to be driven ON by the Gateway.</p> <p><b>Call disconnection:</b></p> <p>Disconnection is identical to mode 4 except that when a call is released, the DAC turns DTR OFF for 0.2 second and then ON. DTR stays ON until the next call release.</p>
Mode 7	Inbound Hotline Gateway access (with forced DTR)	<p><b>Inbound Hotline Gateway protocol:</b></p> <p>The DAC operation is identical to mode 5 except that DTR is always forced ON (except during disconnect).</p> <p><b>Call disconnection:</b></p> <p>Disconnection is identical to mode 6.</p>

**Table 158**  
**Connect and disconnect protocol (Part 7 of 12)**

Mode of operation	Interface application	Comments
Mode 8	Host access for call origination and answering	<p><b>Host answering an incoming data call:</b></p> <p>Local DM user dials the access number to initiate the connection.</p> <p>DAC responds by driving RI ON for 2 seconds and OFF for 4 seconds until the Host answers by turning DTR ON. (If the Host always drives DTR ON, the DAC immediately answers the call without driving RI ON.)</p> <p>When Host receives RI ON, it should respond by turning DTR ON.</p> <p>DAC answers when it receives DTR ON.</p> <p>DAC turns DSR, DCD, and CTS ON when the call is completely established. The local DM user is now transparently linked to the Host.</p> <p><b>Host originating a data call:</b></p> <p>Host turns DTR ON to initiate the connection.</p> <p>DAC prepares to receive &lt;CR&gt; for autobaud.</p> <p>Host sends &lt;CR&gt; followed by other commands for establishing a data call (the DAC does not echo a command, nor does it send any prompt to the Host (blind dialing).</p> <p>When the data call is completely established, the DAC turns DSR, DCD, and CTS ON as long as the call is connected.</p>

**Table 158**  
**Connect and disconnect protocol (Part 8 of 12)**

Mode of operation	Interface application	Comments
		<p><b>Call disconnection (DAC):</b></p> <p>DAC drops DSR, DCD, and CTS if the local DM user releases the call. The Host should then drop the call.</p> <p>DAC drops DSR, DCD, and CTS if the Host sends a long break or three short breaks. The Host should then drop the call.</p> <p><b>Call disconnection (Host):</b></p> <p>The Host toggles DTR from ON to OFF (DTR must be OFF for 100 ms or more). The DAC drops DSR, DCD, and CTS and disconnects the local call.</p>
Mode 9	Hotline call origination	<p><b>Hotline originated by Host (Inbound):</b></p> <p>Host toggles DTR from OFF to ON to initiate the Hotline call.</p> <p>DAC responds by trying to establish a Hotline call to a specific Data Module (Autodial).</p> <p>3When Data Module answers, then and only then, the DAC turns DSR, DCD, and CTS ON (the DAC does not send any prompts to the Host). If the Data Module is busy or not responding, the DAC requires another transition of DTR from OFF to ON to initiate another Hotline call. If the Host keeps DTR ON, the DAC does not try to establish another Hotline call, unless the Host sends a &lt;CR&gt; while DTR is ON.</p> <p><b>Call disconnection:</b></p> <p>Disconnection is identical to mode 8.</p>

**Table 158**  
**Connect and disconnect protocol (Part 9 of 12)**

<b>Mode of operation</b>	<b>Interface application</b>	<b>Comments</b>
Mode 10	Host access for call origination and answering (with forced DTR)	<p><b>Host access for call origination and answering:</b></p> <p>The DAC operation is identical to mode 8 except DTR is always considered ON, even when the Host is driving DTR OFF.</p> <p><b>Call disconnection:</b></p> <p>DAC drops DSR, DCD, and CTS if the local DM user releases the call. The Host should then drop the call.</p> <p>DAC drops DSR, DCD, and CTS if the Host sends a long break or three short breaks. The Host should then drop the call.</p>
Mode 11	Hotline call origination (Virtual Leased Line)	<p><b>Hotline origination by Host (continuous Hotline mode):</b></p> <p>The DAC operation is similar to mode 9 except the Host initiates the Hotline call by driving DTR ON. However, if the DM is busy or not answering, the DAC will continuously try to originate Hotline calls once every 40 seconds (as long as DTR stays ON) until the called DM answers the call.</p> <p><b>Call disconnection:</b></p> <p>Disconnection is identical to mode 8.</p>

**Table 158**  
**Connect and disconnect protocol (Part 10 of 12)**

Mode of operation	Interface application	Comments
Mode 12	Terminal access for call origination and answering	<p><b>Terminal answering an incoming data call:</b></p> <p>DAC drives DSR, DCD, and CTS ON in the idle state.</p> <p>Local DM user dials the access number to initiate the connection.</p> <p>DAC responds by driving RI ON for 2 seconds and OFF for 4 seconds, until the terminal answers by turning DTR ON (if the terminal always drive DTR ON, the DAC immediately answers the call without driving RI ON).</p> <p>When terminal receives RI ON, it should respond by turning DTR ON.</p> <p>DAC answers when DTR goes ON and the local DM user is now transparently linked to the terminal.</p> <p><b>Terminal originating an outgoing data call:</b></p> <p>DAC drives DSR, DCD, and CTS ON in the idle state.</p> <p>Terminal turns DTR ON to initiate the connection.</p> <p>DAC prepares to receive &lt;CR&gt; for autobaud.</p> <p>Terminal sends &lt;CR&gt; followed by other commands for establishing a data call (the DAC echoes all commands).</p> <p><b>Call disconnection (DAC):</b></p> <p>If the local DM user releases the call, the DAC turns DSR, DCD, and CTS OFF for 0.2 second and then ON.</p>

**Table 158**  
**Connect and disconnect protocol (Part 11 of 12)**

Mode of operation	Interface application	Comments
		<p><b>Call disconnection (terminal):</b></p> <p>Terminal toggles DTR from ON to OFF (DTR must be OFF for 100 ms or more). The DAC turns DSR, DCD, and CTS OFF for 0.2 second and then ON.</p> <p>Terminal sends a long break or three short breaks. The DAC turns DSR, DCD, and CTS OFF for 0.2 second and then ON.</p>
Mode 13	Hotline call origination	<p><b>Hotline originated by terminal:</b></p> <p>DAC drives DSR, DCD, and CTS ON in the idle state.</p> <p>Terminal toggles DTR from OFF to ON to initiate Hotline call.</p> <p>DAC responds by trying to establish a Hotline call to a specific DM (Autodial).</p> <p>If Data Module is busy or not responding, the DAC requires another transition of DTR from OFF to ON to initiate another Hotline call. If the terminal keeps DTR ON, the DAC does not try to establish another Hotline call unless the terminal sends a &lt;CR&gt; while DTR is ON.</p> <p><b>Call disconnection:</b></p> <p>Disconnection is identical to mode 12.</p>
Mode 14	Terminal access for call origination and answering (with forced DTR)	<p><b>Terminal access for call origination and answering:</b></p> <p>The DAC operation is identical to mode 12 except that DTR is considered to be always ON, even when the terminal is driving DTR OFF.</p>

**Table 158**  
**Connect and disconnect protocol (Part 12 of 12)**

Mode of operation	Interface application	Comments
		<p><b>Call disconnection (DAC):</b></p> <p>If the local DM user drops the call, the DAC turns DSR, DCD, and CTS OFF for 0.2 second and then ON.</p> <p><b>Call disconnection (terminal):</b></p> <p>The terminal sends a long break or three short breaks. The DAC turns DSR, DCD, and CTS OFF for 0.2 second, and then ON.</p>
Mode 15	Hotline call origination (Virtual Leased Line)	<p><b>Hotline call origination by terminal:</b></p> <p>The DAC operation is similar to mode 13 except the terminal initiates the Hotline call by driving DTR ON. However, if the called DM is busy or not answering, the DAC will continuously try to originate Hotline calls once every 40 seconds (as long as DTR remains ON) until the Data Module answers the call.</p> <p><b>Call disconnection:</b></p> <p>Disconnection is identical to mode 12.</p>

## Keyboard dialing

Keyboard dialing is an interactive dialogue mode between the connected equipment and the DAC. This dialogue allows equipment to give dialing commands to the DAC in order to make a data call to another far-end data port. Keyboard dialing supports a modify mode that allows the user to modify certain dialing parameters.

The following keyboard dialing features are supported with the DAC:

- Autobaud from 110 to 19200 bps



- Autoparity to ensure that the keyboard dialing menu is readable on the data terminal during the interactive dialogue mode
- Originating calls to local and remote hosts
- Ring Again
- Speed Call
- Two answer modes for incoming calls: manual and auto
- Digit display
- Dialing by mnemonic

## Initiating conditions

In order for the DAC to respond to user commands/entries, the following conditions must be met:

- The DAC must be active (power ON), and have successfully received the downloaded parameters from the system.
- The user equipment must be active, and, if in RS-232-C mode, must assert these control lines
  - DCE mode: DTR (unless Forced DTR has been software selected)
  - DTE mode: RI has cycled the appropriate number of times

## Echo

During call setup (dialogue phase), all user input is echoed back to the user equipment. Once the call is established, the DAC is transparent to data communication. To get echoed characters after a call is established, the far end must provide the echo.

*Note:* When RS-232-C modes 12-15 (Host modes) are selected, there is no echo during dialogue phase.

## Prompts

Call processing prompts are in upper case letters only. Other prompts consist of both upper and lower case characters, and the dialogue session depicts the actual upper/lower case letters used.

All prompts are preceded by the Carriage Return and Line Feed ASCII characters (<CR>, <LF>).

Prompts requesting user input are terminated with the ASCII colon (:).

Prompts requiring a Yes or No answer are terminated by a question mark (?), followed by a list of allowable responses. The default response, if allowed, is bracketed.

## Call abort

In addition to the methods mentioned above, which are common to both Hayes and keyboard modes, keyboard dialing supports the following method to abort a call during the dialogue phase.

- Sending the Control Z character (simultaneously pressing the control and Z keys) sends a message to the DAC to immediately abandon the data call setup.

## Autobaud

All user dialogue must begin with Autobaud detection. This allows the DAC to determine the user equipment baud rate. During this phase, only <CR> will be recognized by the DAC. All other entries are ignored, and no entries are echoed. Once a valid <CR> is detected, the DAC responds with the New Menu prompt at the baud rate detected. If a fixed rate has been determined by the downloaded parameters, the DAC will look for that rate. If the rates agree, the dialogue phase begins. If not, the following prompt is sent to the user:

### **Baud Rate xxxx expected**

After receiving a number of invalid responses, the DAC reverts to autobaud detection, since the terminal data speed may have changed.

Keyboard Autobaud is allowed after the call is placed in off-line mode.

**Note:** If the Hayes autobaud characters A or a are sent, the DAC will enter Hayes dialing mode. Autobaud character detection is selected in the software.

## Auto parity

The user can override the downloaded parity rate by entering the ASCII period (.) as a command. This period must be the only command sent, followed by <CR>. The period must be sent only when the Primary menu is displayed, and can be sent only once during a call setup session.

## Dialing operation

For the purposes of this document, when illustrating the prompt/response sequences, the bold type is what the user enters on the keyboard. All other type represents the DAC output. Likewise, "xxxxxxx," "yyyyyyy," or "zzzzzzz" represents numbers entered by the user, or dialed by the DAC, and in no way indicates the absolute character limit. A maximum of 43 characters is allowed.

When the user enters the autobaud character, <CR>, and the dialing mode is Manual (not Hotline), the DAC sends the following menu:

```
<CR><LF><CR><LF><LF>ENTER NUMBER OR H (FOR HELP):<SP>
```

If the user enters <CR>, the DAC presents this prompt again. When a number is entered, the DAC attempts to place the call. Entering H at this point will list the Primary Commands menu:

Primary Commands Menu:

```
A - Auto Dial C - Call  
D - Display M - Modify  
S - Speed Call  
CTRL Z (Abort Keyboard Dialing)  
Select: <SP>
```

Whenever a Primary command is expected, the user may enter the Parity command (period). If Auto Parity has already been done, the Invalid Command menu is presented:

Invalid Command/Entry  
Re-Enter: <SP>

The user's port may be set to idle by entering CTRL Z. Any call in progress will be dropped, and any Ring Again placed will be released. Once the Primary Command menu has appeared, the user must enter C to place a call. The DAC will not accept a number in place of a Primary command.

## Primary commands

Once the Primary menu has appeared, only primary commands are accepted.

### Call (C)

The Call command must be used to place a call once the Primary menu has appeared. The DAC will not accept a number only.

**C<CR>**

ENTER NUMBER:<SP>

**xxxxxxx<CR>**

CALLING xxxxxxx  
RINGING  
ANSWERED  
CALL CONNECTED. SESSION STARTS

**Autodial (A)**

The Autodial command allows the user to dial a predefined number stored within the local system. The DAC will automatically attempt to place a data call to the Autodial number:

**A <CR>**

CALLING xxxxxxxx

RINGING

ANSWERED

CALL CONNECTED. SESSION STARTS

The currently stored Autodial number may be viewed by entering the primary command D (Display), followed by the selection A (Autodial). See the Display discussion later in this document.

*Note:* If the Autodial feature key is not defined in the software you will be notified by the following: Feature key Autodial not defined.

**Speed Call (S)**

The Speed Call command allows the user to make a call to a number associated with a 1-, 2-, or 3-digit access code. The user supplies the access code, and the DAC places the call according to the code supplied.

**S<CR>**

ENTER ACCESS CODE: <SP>

**xxx<CR>**

CALLING yyyyyy

RINGING

ANSWERED

CALL CONNECTED. SESSION STARTS

If the DAC does not know the access code length, you will be notified by:  
ENTER ACCESS CODE (all digits) <SP>. Leading zeroes must be entered

if the access code is less than the maximum number of digits allowed for the Speed Call list for the associated data DN (DDN).

*Note:* If the Speed Call feature key is not defined in the software, you will be notified by the following: Feature key Speed Call not defined.

Both the Autodial and Speed Call commands can be changed with the Modify command (M). Additionally, the Speed Call number can be changed in the service change. When this command is entered, the Modify menu appears.

Modify Menu:

A - Auto Number D - DCD Control  
L - Long Break M - Manual Answer  
Q - Quit Modify Menu R - Remote Loopback  
S - Speed Call  
CTRL Z (Abort Keyboard Dialing)  
Select:<SP>

Any of these choices leads to another series of prompts and responses.

By entering A on the keyboard, you enter the Autodial Modify menu. Respond to the following prompts to change the Autodial number.

**A <CR>**

Current Autodial number: zzzzzzz

Enter Autodial number: <SP>

**xxxxxxx <CR>**

New Autodial number: xxxxxxx

By entering S on the keyboard, you enter the Speed Call Modify menu. The Speed Call number can also be changed in the software. Respond to the following prompts to change the Speed Call number.

**S<CR>**

Enter access code <SP>

Current Speed Call number: zzzzzzz

Enter Speed Call number: <SP>

**zzzzzzz<CR>**

New Speed Call number: xxxxxxx

By entering R on the keyboard, you enter the Remote Loopback Modify menu. Respond to the following prompts to enable or disable the Remote Loopback feature.

**R <CR>**

Remote Loopback Disabled (or enabled, indicating current status)

Remote Loopback

(Y/N): <SP>

**Y <CR> or N <CR>**

Remote Loopback: Enabled (or Disabled)

By entering M on the keyboard, you enter the Manual Answer Modify menu. Manual Answer indicates that the DAC prompts the user to answer an incoming data call. Auto answer picks up the call after the specified number

of rings. Respond to the following prompts to enable or disable the Manual Answer feature.

**M <CR>**

Current Answer Mode: Manual  
Auto - xx Rings

Manual Answer? (Y/N): <SP>

**Y <CR> N <CR>**

Number of rings (1-255 <1>): <SP>

**yy**

New Answer Mode: Manual New Answer Mode: Auto - yy Rings

By entering D on the keyboard, you enter the DCD Modify menu. Respond to the following prompts to enable DCD as Forced or Dynamic.

**D <CR>**

DCD Control:Dynamic  
Forced On

Dynamic DCD? (Y/N): <SP>

**Y <CR> N <CR>**

DCD Control: DynamicDCD Control: Forced On



By entering L on the keyboard, you enter the Long Break Detect Modify menu. Respond to the following prompts to enable or disable the detection of the Long Break as an abandon signal.

**L <CR>**

Long Break: Detected  
Ignored

Detect Long Break? (Y/N): <SP>

**Y <CR> N <CR>**

Long Break: Detected Long Break: Ignored

To exit the Modify menu, enter Q. This entry returns you to the Primary commands menu. To view the port's parameters, enter D when in the Primary Commands menu. This display shows the Display Options menu.

Display Options Menu:

A - Auto Dial number D - Date and Time  
K - Feature Keys P - Data Port Parameters  
Q - Quit Display S - Speed Call number(s)  
CTRL Z (Abort Keyboard Dialing)  
Select: <SP>

## Ring Again

When a call is placed to a busy DN, the DAC prompts you to activate Ring Again. The Ring Again feature alerts you as soon as the dialed DN becomes free. Once the Ring Again has been activated, you will return to the Primary Commands menu. The following is the prompt and response sequence enabling the Ring Again feature.

*Note:* If you hang up the call, or give an abandon command, Ring Again is canceled.

BUSY, RING AGAIN? (Y/N): <SP>

**Y <CR> or N <CR>**

RING AGAIN PLACED

Primary Commands Menu:

A - Auto Dial C - Call

D - Display M - Modify

S - Speed Call

CTRL Z (Abort Keyboard Dialing)

Select: <SP>

If a Ring Again request has already been placed, the DAC offers the option of overriding the previous request.

RING AGAIN ACTIVE, REPLACE? (Y/N): <SP>

**Y <CR>**

RING AGAIN PLACED

Primary Commands Menu:

A - Auto Dial C - Call

D - Display M - Modify

S - Speed Call

CTRL Z (Abort Keyboard Dialing)

Select: <SP>

When the called DN becomes available, the system notifies the DAC, which then prompts the user to place the call. If you do not respond to the Ring

Again prompt within a software determined time period, Ring Again is canceled, and the Primary Commands Menu appears.

DATA STATION NOW AVAILABLE, PLACE CALL? (Y/N/<Y>): <SP>

**Y <CR>**

CALLING XXXX  
RINGING  
ANSWERED  
CALL CONNECTED. SESSION STARTS

*Note 1:* If the Ring Again notice occurs during a parameter change, the prompt only appears after the change has been completed.

*Note 2:* If the notice occurs during an active call, the Ring Again notice is ignored. When the active call is completed, you will be notified that the Ring Again call was canceled.

You can also cancel the Ring Again request at this time.

DATA STATION NOW AVAILABLE, PLACE CALL? (Y/N/[Y]): <SP>

**N <CR>**

RING AGAIN CANCELLED  
Primary Commands Menu:  
A - Auto Dial S - Speed Call  
C - Call M - Modify  
D - Display  
CTRL Z (Abort Keyboard Dialing)  
Select: <SP>

## Not in service

When the DAC attempts a call to a DN that is not supported, it sends you a message. The call is released, and you must reenter the Autobaud character <CR> to initiate keyboard dialing again.

**C<CR>**

ENTER NUMBER:<SP>

**xxxxxxx<CR>**

CALLING xxxxxxx

NOT IN SERVICE

RELEASED

## No response from the system

Likewise, when the DAC receives no system response from your port after a 30-second timeout period, the DAC sends you a message. The call is abandoned. This means the port is either disabled or unequipped.

**C<CR>**

ENTER NUMBER:<SP>

**xxxxxxx<CR>**

NO SYSTEM RESPONSE

RELEASED

## Hayes dialing

Like keyboard dialing, Hayes dialing is an interactive dialing mode with the terminating equipment connected to the NT7D16 Data Access Card (DAC). In addition to the common parameters and functions, the Hayes dialing mode offers the following features:

- Data call dialing
- Two modes for answering incoming calls: auto and manual
- Repeat previous command
- Character echo control
- On-hook/off-hook control
- Detect off-line escape sequence
- Return to on-line
- Initiate Remote Digital Loopback
- Terminate Remote Digital Loopback
- Modify S Registers S0 through S12
- Display S Registers S0 through S12
- Support all S Registers except: S6, S7, S9, and S11

The Hayes dialing mode supports the following AT Dialing commands.

### Initiating conditions

The DAC responds to commands only when the following initial requirements are met:

- the DAC is active
- the DAC has successfully received the downloaded parameters
- the user equipment is active, and, if operating in RS-232-C mode
  - the DCE mode is DTR (unless Forced DTR has been software selected)

- the DTE mode, and RI has cycled the appropriate number of times and DCD is asserted on by the modem

**Note:** In Gateway mode, DCD must be asserted on. In modem mode, only RI must be on. The DAC asserts DTR to the modem, and awaits DCD from the modem.

## Input requirements

All input must be in the same case (upper or lower).

The Hayes repeat command, A/, is used to immediately execute the last command entered. The terminator character need not be entered. A complete discussion of the Repeat command can be found later in this document.

Where a Dial Number is expected, you may enter the characters 0-9, #, and comma (.). The characters @, P, R, T, and W are accepted, but ignored.

The maximum number of characters is 43. This limit includes the AT prefix, and the record Terminator character, but does not include the ASCII space character.

## Echo

Throughout the dialogue phase, the DAC echoes all user input. In RS-232-C modes 0, 1, 2, and 3, no inbound call messages are presented to the modem. Prompts are presented only if the modem user originates the call. In modes 8, 9, 10, and 11, no prompts or characters echo under any circumstances. The echo function can be turned off with a Hayes dialing command.

All prompts and responses issued by the system are displayed to the user unless the display command has been disabled. Like the Repeat command, this is explained later in this document.

**Note:** If the RS-232-C DAC Host modes (1, 2, 3, 8, 9, 10, 11, or 12) are used, all attempts to enable the echo or display is ignored. Likewise, the Hayes Reset command is also ignored.

## Result codes and messages

Each input record generates a result code which is sent to the user. Only one code is sent regardless of the number of commands in the record. The reply is in one of two formats:

- Numeric replies contain a one- or two-number code
- Verbose replies contain one or more words

Table 159 shows the codes for each reply in both formats, and explanations for the codes.

**Note 1:** Verbose commands are the default and appear in upper case characters only. Numeric commands are sent by issuing the Numeric Results code command (explained later in this document).

**Note 2:** All verbose codes and messages are preceded and terminated by the user defined Terminator and New Line characters. The default, or reset, characters are the ASCII Carriage Return, and ASCII Line Feed. The Numeric codes are preceded and terminated by the Terminator character only.

**Note 3:** The Suppress result command (explained later in this document) will disable the sending of these codes. If in RS-232-C DAC Host modes, this command is ignored.

**Table 159**  
**Hayes dialing result codes and messages (Part 1 of 2)**

Verbose code	Numeric code	Description
OK	0	Command(s) executed, no error
CONNECT	1	Data call established, session starts
RING	2	Inbound call presented
NO CARRIER	3	Data call abandoned
ERROR	4	Error in command line
NO DIALTONE	6	System does not allow call to proceed

**Table 159**  
**Hayes dialing result codes and messages (Part 2 of 2)**

<b>Verbose code</b>	<b>Numeric code</b>	<b>Description</b>
BUSY	7	Far end is busy
NO ANSWER	8	Far end does not answer
CONNECT 1200	5	Session starts at 1200 baud
CONNECT 2400	10	Session starts at 2400 baud
CONNECT 4800	11	Session starts at 4800 baud
CONNECT 9600	12	Session starts at 9600 baud
CONNECT 19200	14	Session starts at 19200 baud

## Baud rate detection

Every command line begins with Baud rate detection. This phase allows the DAC to determine the user equipment baud rate. During this phase, the DAC accepts only the ASCII "A," or "a" characters. Once a valid autobaud character is detected, the DAC echoes the parity bit character at the baud rate detected.

*Note:* If Hayes dialing is desired, you must enter the character "A" or "a" BEFORE the <CR>. If Carriage Return (<CR>) is entered before this Hayes dialing command, you will be placed in keyboard dialing mode.

## Parity detection

Once the baud rate has been determined, the DAC accepts only the ASCII characters "T," "t," or "/." If the Repeat character "/" is entered, the previous command is executed. If "T," or "t" is entered, the DAC uses its parity and the parity of the preceding A (a) to determine the user's parity. This parity is used on the following messages and prompts associated with the command lines.



**Note:** The parity determined here overrides the parity downloaded from the system. Also, the T (t) must be entered in the same case as the A (a). If you entered uppercase A for the Baud Rate, you must enter upper case T for the parity.

## Dialing operation

Like keyboard dialing, the Hayes dialing commands allow the user to initiate a data call, as well as change certain dialing parameters. The commands may be entered in either upper or lower case, but must be the same case throughout the command line. Also the case must match the autobaud case.

**Note:** Hayes dialing does not allow for the Ring Again feature. If a call is made to a busy number, that call is abandoned.

Table 160 provides a list of the AT dialing commands.

**Table 160**  
**AT dialing commands (Part 1 of 2)**

Command	Description
ATA	Answer (answer incoming data call)
ATDnnnn ATDTnnnn	Dial (n = 0-9, numbers to be dialed)
A/	Repeat last command (no <CR> needed)
ATO	On-line (enter three Escape characters rapidly to go off-line)
ATDPnnnn	Voice call (n = 0-9, numbers to be dialed)
ATF0	Handsfree/mute (toggle Handsfree between mute and normal)
ATF1	Hold (put voice call on hold)
ATF2	Select (take voice call off hold)
ATH0	Hang up data call
<b>Note 1:</b> To use AT dialing, enter CTRL-z at carriage return (<CR>) when the port is idle.	
<b>Note 2:</b> Follow each command (except A/) by a carriage return (<CR>) to execute it.	

**Table 160**  
**AT dialing commands (Part 2 of 2)**

Command	Description
ATHP	Hang up voice call
ATQn	Result code (n = 0, 1; if n = 0, result codes are sent)
ATVn	Verbal result (n = 0, 1; if n = 0, numeric codes are sent)
ATXn	Result code selection (n = 0, 1; if n = 1, extended results)
ATSn	Read S register (n = number of S register to read)
ATSn=x	Write S register (n = S register number; x = new value)
ATZ	Soft reset (reset to default parameters)
ATCn	Carrier detect (n = 0, 1; if n = 1, carrier detect is enabled)
ATEn	Echo (n = 0, 1; if n = 1, commands will echo back to terminal)
ATTSP!	Transparent mode
<b>Note 1:</b> To use AT dialing, enter CTRL-z at carriage return (<CR>) when the port is idle.	
<b>Note 2:</b> Follow each command (except A/) by a carriage return (<CR>) to execute it.	

For the purposes of this document, when illustrating the prompt/response sequences, the bold type is what the user enters on the keyboard. All other type represents the DAC output. Likewise, “xxxxxxx,” “yyyyyyy,” or “zzzzzzz” represents numbers entered by the user, or dialed by the DAC, and in no way indicates the absolute character limit. The number of characters is dependent on the feature activated (Auto Dial, Speed Call, for example). Also, for simplicity purposes, all Result messages are shown in Verbose code. See Table 159 on [page 487](#) for a complete list of the Verbose and Numeric codes. See *Features and Services* (553-3001-306) for a complete description of the features operating.

## S registers

These commands allow the user to access various dialing parameters. The user can determine the present parameter setting, and alter the parameter. These parameters are grouped into a set referred to as the S registers.

All S registers may be changed with the exception of S1, the Ring count. If an attempt is made to change this parameter, the command is accepted but no action is taken. The Ring count is the number of 6-second intervals that have expired since an inbound call has been received. The current count may be displayed through the Display S register command but cannot be altered. After a call is dropped, the Ring counter is set back to 0.

If, when using the display or alter commands, no register or value number is input, the number 0 is used. For example, ATSP? is equivalent to ATSP0.

Allowable S registers Table 161 shows the supported S registers allowed by the DAC. This table shows the register number, the range accepted (decimal values shown), and a description of the register. Whenever a register value is changed, the DAC checks for validity. If the value entered is not within the allowed range, all processing ceases and no command processing following the invalid entry is accepted. The DAC sends an ERROR result message.

**Table 161**  
**Allowable S registers (Part 1 of 2)**

S register	Range	Range units	Supported	Description
S0	0–255	Rings	Yes	Number of rings to answer a system call (0 = manual answer)
S1	0–255	Rings	Yes	Ring count for the current inbound system call
S2	0–127	ASCII	Yes	Off-line escape sequence character
S3	0–127	ASCII	Yes	Input/output line terminating character
S4	0–127	ASCII	Yes	New line character for the output line
S5	0–32, 127	ASCII	Yes	Backspace character for input/output lines
S6	2–255	Seconds	No	Wait time before blind dialing
S7	1–255	Seconds	Yes	Timeout timer for far end answering

**Table 161**  
**Allowable S registers (Part 2 of 2)**

S register	Range	Range units	Supported	Description
S8	0–30	Seconds	Yes	Duration for the dial pause character
S9	1–255	0.1 second	No	Carrier detect response time
S10	1–255	0.1 second	No	Delay time between loss of carrier and call release
S11	50–255	Milliseconds	No	Touch tone spacing
S12	20–255	20 milliseconds	Yes	Guard time for the escape sequence

You can view any of the S registers by issuing the following display command. Any S register can be specified through the ATS command, and the system will display the current setting for that parameter. More than one S register can be viewed by listing the desired registers on the same command line.

One registerTwo registers

```

ATS8? ATS8? S9
20      002
OK      006
        OK
    
```

To change any S register range, except S1, use the following change command. The new parameters remain in effect until another change command is given or the Hayes Reset modem command (Z) is issued. If the DAC is powered up, the parameters are reset to the defaults.

```

ATS8 = 15
OK
    
```

## Reset Hayes parameters

All of the Hayes dialing parameters and S registers remain even after the data call is complete. Similarly, if the dialing mode, keyboard to Hayes or vice versa, are changed, the parameters remain as specified. The following command allows you to reset the parameters and S registers to the defaults. Entering 0 resets to the Hayes default, while entering 1 resets to the downloaded operating parameters.

### CAUTION

**All previous instructions will be ignored.**

This command should only be used to reset all parameters. It should be the last command entered, because all previous commands are ignored.

**ATZ0**

**1**

OK

Table 162 lists all the parameter and S register default values. These are the values established when the reset command is given.

**Table 162**

**Hayes parameters and S register reset values (Part 1 of 2)**

Parameter	Value	Description
C	1 *	DCD controlDynamic (1) Forced ON (0)
E	1 *	Input character echo Enabled (1) Disabled (0)
Q	0	Send Result codesEnabled (1) Disabled (0)
* Parameters that are reset to the downloaded operating parameters when 1 is entered at the reset command.		

**Table 162**  
**Hayes parameters and S register reset values (Part 2 of 2)**

Parameter	Value	Description
V	1	Result codes sent in Verbose format
X	1	Features selection 0 - 8, 10 - 13
P	—	Dial method (pulse)
S0	0 *?1	Manual Answer (if 0)?Auto answer on 1 ring
S1	0	Ring count 0
S2	43	Escape sequence character Plus sign (+)
S3	13	Terminator character Carriage Return (<CR>)
S4	10	New line character Line Feed (<LF>)
S5	8	Back space character BS (<BS>)
S6	2	Blind dial delay 2 seconds
S7	30	Timeout for outbound call answer 30 seconds
S8	2	Dial pause delay 2 seconds
S9	6	Carrier detect response time 0.6 seconds
S10	14	Call disconnect timer for carrier loss 1.4 seconds
S11	95	Touchtone space 95 milliseconds
S12	50	Escape sequence guard timer 1.00 seconds

\* Parameters that are reset to the downloaded operating parameters when 1 is entered at the reset command.

## Outbound calls

The DAC supports two types of outbound data calls:

- point-to-point data calls
- calls sent through a modem without call origination capabilities

Hayes dialing does not provide for any alterations during call processing, Ring Again, or Controlled Call Back Queueing (CCBQ) for example. Consequently, if such variances occur during the call processing, the DAC releases the call and notifies you with a NO CARRIER or BUSY result code. Table 163 lists the command characters allowed for an outbound call.

**Table 163**  
**Allowed outbound call command characters**

Character	Description
0 - 9	Dial number normal digits
,	Delay dialing the next digit by the value set in S8 register

## Inbound calls

The DAC supports auto answer and manual answer capabilities. The following commands give examples of both auto and manual answer dialogues.

This dialogue session describes the sequence when the S0 register is set to three. In this case, the DAC automatically answers the incoming call on the third ring, and the session begins with the CONNECT message.

RING

RING

RING

CONNECT

Issuing the On Hook command while the call is still ringing disconnects the incoming call. The DAC disconnects the call and notifies you with a NO CARRIER message.

RING

RING

**ATH0**

NO CARRIER

When the S0 register is set to 0, the DAC is set to manual answer, and an inbound call must be answered with the Answer command. You can also abandon the call with the On Hook message, as in the Autodial sequence.

RING

RING

**ATH0**

NO CARRIER

## Off Line mode

Off Line mode acts as a sort of Hold mode. Once the call is answered and the session begins, the Off Line command enables you to enter Hayes command modes. The Off Line sequence is transmitted to the far-end, but at the end of the sequence, the command mode is initiated. At this point, any Hayes command except Dial Number can be executed. Once the desired command is completed, you can return to the call through the On Line command.

The Guard Time (S12 register) defines the amount of time for no local input for the Off Line escape sequence to take place. If the S12 register is set to 0, enter the escape character defined in the S2 register. For a complete list of the parameters allowed for each S Register, see Table 162 on [page 493](#) describing the S Registers.



In the following example, <GT> is the Guard Time and <EC> the Escape Character defined in the S2 register. The example shows the Off Line escape sequence, the command to display an S register (Ring Count, in this case), and the command to go back on line and attend to the answered call.

<GT><EC><EC><EC><GT

OK

**ATS1**

005

OK

**AT00**

CONNECT

## Specifications

### QPC430 and QPC723 interfaces

The NT7D16 Data Access card provides the same features as the QPC430 four-port Asynchronous Interface Line Card (AILC) and the QPC723 RS-232 Interface Line Card (RILC). The operational mode for each port is determined in LD 11.

### Download parameters

These parameters are configured in the system through service change operations. They are then downloaded to the DAC. For a complete description of the service change procedures, see the *Software Input/Output: Administration* (553-3001-311).

## System parameters

System parameters downloaded by the switch include the type of system, the inactivity timer, and the data DN. These parameters are described below:

- System type: CS 1000S, CS 1000M, and Meridian 1
- Inactivity timeout
  - No timeout
  - 15 minutes
  - 30 minutes
  - 60 minutes
- DDN: 1 to 7 digits (0–9)

## Operating parameters

There are thirteen parameters configured in the system that are downloaded to the DAC. They are:

- Dialogue parity
  - Space (OFF)
  - Mark (ON)
  - Even
  - Odd
- DTR control
  - Dynamic (affected by call progress)
  - Forced ON
- DCD control
  - Dynamic (affected by call progress)
  - Forced ON
- Dialing mode
  - Manual (user initiates the call with dialogue commands)

- Hotline (call the Autodial number upon connection)
- Wire test
  - Disabled (can be invoked only with front panel switch)
  - Enabled (start only if the DAC firmware is idle)
- Language
  - English
  - Quebec French
- Keyboard dialing
  - Enabled (allow both keyboard or Hayes dialing modes)
  - Disabled (Hayes dialing only)
- Make port busy
  - Disabled—On with DTR (normal)
  - Enabled—Off with DTR (modes 8 or 12, and no DTR for 5 seconds)
- Auto Baud
  - Variable (use auto baud rate)
  - Fixed (use baud rate selection only)
- Baud rate
  - 110
  - 150
  - 300
  - 600
  - 1200
  - 2400
  - 4800
  - 9600
  - 19200
- Operating mode

- DCE
- DTE
- Equipment type
  - Terminal (send prompts/replies)
  - Host (suppress prompts/replies)
- Long Break Detect

In Figure 95 on [page 501](#) and Figure 96 on [page 502](#), the rectangles represent the settings of service change parameters in LD11 that affect the desired function. The diamonds represent the logical DAC operating mode decisions.

## Upload parameters

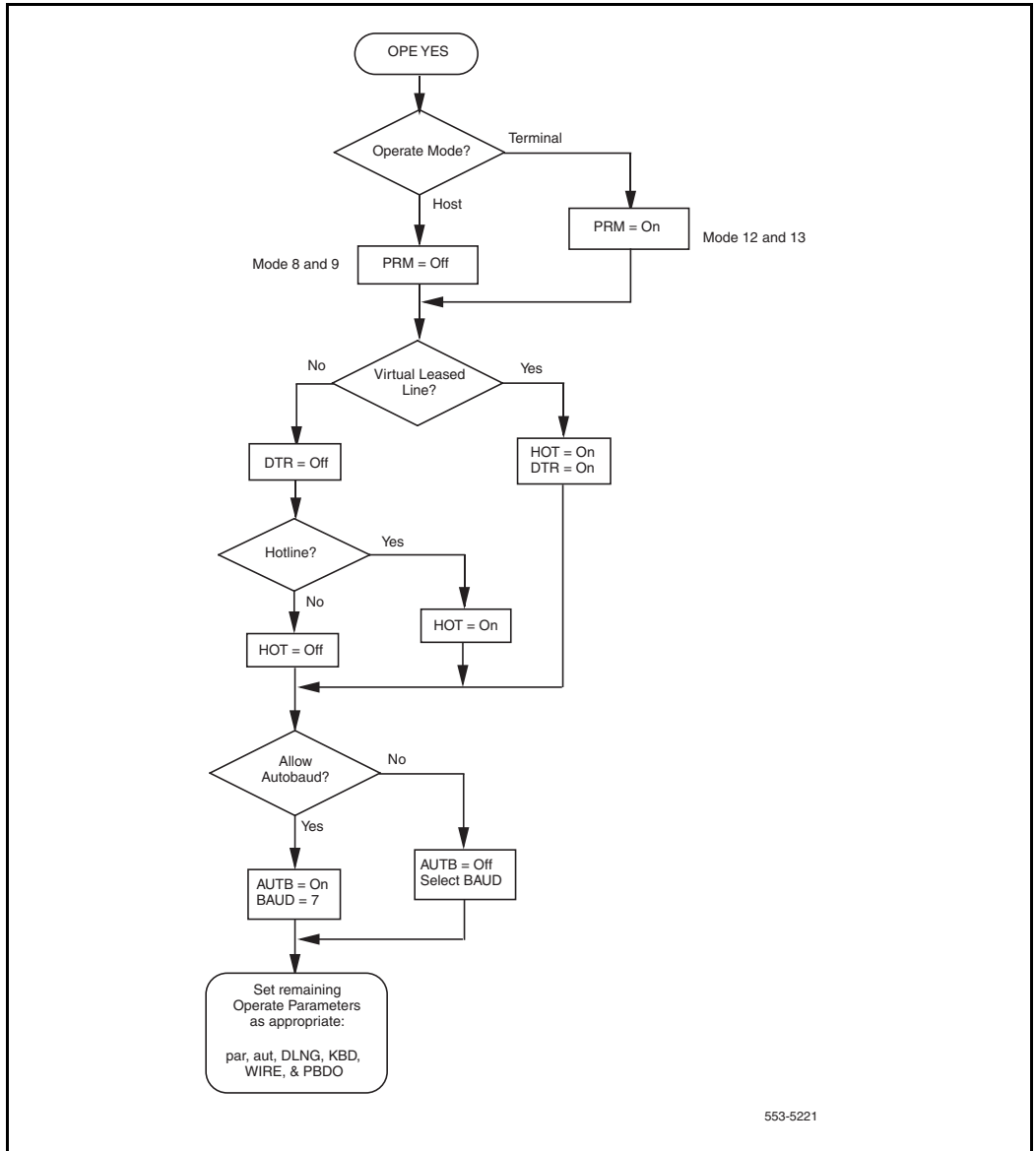
The system can, at any time, request information from a DAC port. The uploaded parameters contain information about the individual card (card type, order code, release information), as well as the status of the configured operating parameters. Because the dialogue operations of data calls can affect the operating parameters, this is useful to monitor and confirm port settings. An additional parameter is listed in the uploaded information: port interface mode (RS-232-C/RS-422). The interface is set by the use of jumpers on the DAC, and cannot be altered by the service change.

## System database requirements

To ensure proper operation of the DAC keyboard and Hayes dialing, the system requires the following:

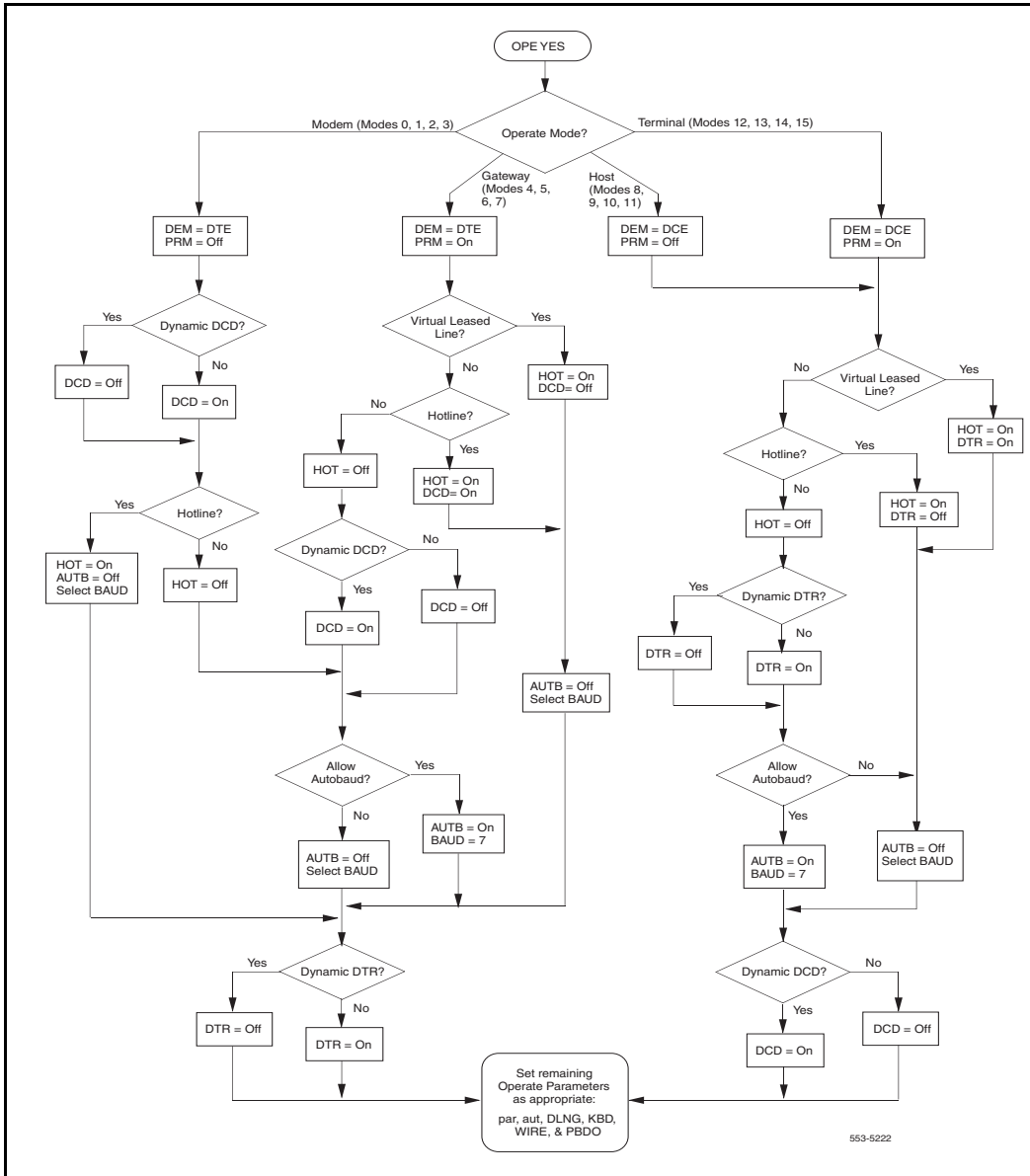
- The Data DN must have only one appearance.
- For access to remote hosts, the TNs class of service must allow external calls. The Data TN must have the following in its class of service:
  - Call Pickup Denied (PUD)
  - Call Forward No Answer Denied (FND)
  - Call Forward Busy Denied (FBD)
  - Data (DTA)

**Figure 95**  
**Operating mode selection—RS422**



553-5221

Figure 96  
Operating mode selection—RS-232-C



**Note:** Warning Tone Denied (WTD) defaults if DTA is entered.

- If the DAC is used to call out through modem pooling, where the modem pool consists of dumb modems connected to QMT8 SADM or QMT12 V.35 SADM, the DAC port should be configured with a secondary DN, which has a single appearance.
- The Virtual keys must be assigned as shown in Table 164.

**Table 164**  
**Virtual key assignments**

Feature key	Key number		Use
	SL-1	SL-100	
Data DN	0	0	Required
Secondary DN	1	1	Required for manual modem pooling
Call Transfer	2	—	Required for manual modem pooling
Auto Dial	3	2	Required for Hotline and VLL
Ring Again	4	6	Optional
Speed Call	5	3	Optional
Display	6	—	Required
Make Set Busy	7	7	Optional

## Power supply

Be sure that all power requirements are met before installing the DAC.  
Operation may be affected by improper power and environmental conditions.

## EIA signals supported

The DAC supports a subset of the standard signals. Only 8 leads can be brought through the backplane connector for each port, totaling 48 leads for each card slot. Table 165 lists the EIA signals supported on this card.

**Table 165**  
**EIA signals supported (RS-232-C)**

EIA	DB-25 Pin	Signal abbreviation	Description	DCE mode	DTE mode
BA	2	TD	Transmitted Data	In	Out
BB	3	RD	Received Data	Out	In
CB	5	CTS	Clear To Send	Out	In
CC	6	DSR	Data Set Ready	Out	In
AB	7	GND	Signal Ground	—	—
CF	8	DCD	Carrier Detect	Out	In
CD	20	DTR	Data Terminal Ready	In	Out
CE	22	RI	Ring Indicator	Out	In

**Note:** RS-422 leads supported are: Tx (transmit) and Rx (receive).



## Environmental

The DAC functions fully when operating within the following specified conditions. See Table 166.

**Table 166**  
**DAC environmental specifications**

Specification	Operating	Storage
Ambient temperature	0 to 60 degrees C	40 to 70 degrees C
Humidity	5% to 95%	5% to 95%

## Reliability

The DAC has a predicted mean time between failure (MTBF) of 8 years at 45 degrees Celsius. The mean time to repair (MTTR) is 1 hour.

## Installing the Data Access card

### Cabinet system

The DAC is fully supported in any card slot in either the main or expansion cabinet without any hardware modification. Insert the DAC into any available card slot and secure it in place using the locklatches.

To cable out the DAC, run a standard 25-pair cable to the cross connect, or use one of the following breakout cables in conjunction with an Amphenol 50-pin female-to-female gender converter:

- QCAD318A50-pin Amphenol to 6 female DB25 connectors
- QCAD319A50-pin Amphenol to 6 male DB25 connectors

**Note:** For Cabinet system, the format to be used in response to the “TN” prompt must be one of the following:

CC 00 00 UUCC - Card Slot  
or CC UUUU - Unit Number

## Large System

In Large Systems, the DAC is fully supported in IPE modules. These special slots on the DAC have 24-pair cables pre-wired to the Main Distribution Frame (MDF) in card slots 0-15. Any IPE slot will support the first four ports on the DAC if connections are made at the MDF. Most IPE modules can be upgraded to wire 24-pair cables to the MDF for all card slots.

*Note:* For directions concerning the pinouts for the MDF, refer to *Communication Server 1000M and Meridian 1: Large System Installation and Configuration* (553-3021-210).

Before you begin, power down:

- the IPE module only, if it is a DC-powered system
- the entire column, if it is an AC-powered system

It is recommended that you begin the installation from the right hand side (when facing the backplane), starting with slot 0 and moving towards slots on the left side. If you wish to add more than six DACs, and require slots 8 through 15, remove the input/output (I/O) panel. Be aware that a full shelf installation can take up to 3 hours. You need the following equipment to upgrade the cabling:

- A0359946 Amphenol cables
  - These connectors include all the connector and screw apparatus.
  - You need one cable for each DAC.
- cable ties
- wire cutters
- A3/16 nutdriver

## System compatibility

To support the 24-pair requirement of the DAC, some cabling may need to be upgraded (Table 167). See “Upgrading systems” for more information.

Ports 0, 1, 2, and 3 of the DAC work in any standard 16-pair IPE slot (connect directly to the MDF).

An upgraded backplane has three shrouds for each card slot. A backplane that cannot be upgraded has only two shrouds for each card slot.

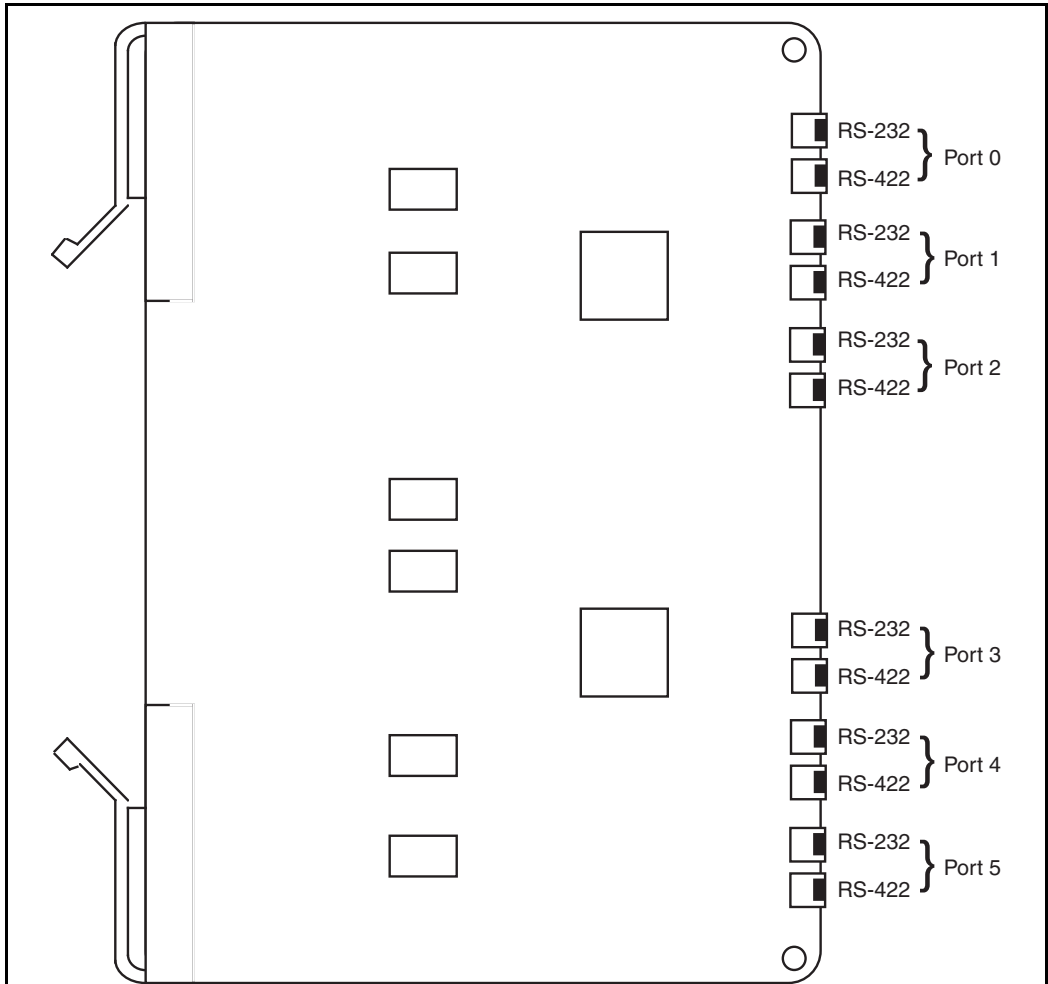
**Table 167**  
**System option compatibility with the DAC**

<b>System option</b>	<b>Backplane code</b>	<b>Backplane release</b>	<b>Upgrade</b>	<b>Maximum no. of ports/DAC supported</b>
Large Systems	NT8D3701	3 and below	No	4
Large Systems	NT8D3701	4 and above	Yes	6

## Port configuration

Figure 97 on [page 508](#) shows the port configurations for both the RS-232-C and RS-422 ports. The software configuration requirements for the DAC are shown at the end of this chapter. Responses to the prompts listed are required. Depending on the configuration, ensure that the option plug is set for RS-232 or RS-422.

Figure 97  
NT7D16 Data Access Card port connectors



**Note:** Insert only one option plug per port.

## Cabling

Several cabling schemes are possible for both AILC and RILC modes. Typical capacitance for 24- and 26-gauge cables is shown in the Tables 168 and 169. RS-232 and RS-422 transmission distance is limited by the electrical capacitance of the cable. Low-capacitance cable carries a digital signal further than a high-capacitance cable.

**Table 168**  
**RS-232-C maximum line capacitance 2,500  $\mu$ F**

Gauge	Capacitance per foot ( $\mu$ F)	Max distance
24	24	104
26	15	166

**Table 169**  
**RS-422 maximum line capacitance 60,000  $\mu$ F**

Gauge	Capacitance per foot ( $\mu$ F)	Max distance
24	24	2500
26	15	4000

Figure 98 on [page 510](#) shows the cabling choices available. It includes cabling with the RS-232-C cable, associated patch panel, the RJ-11, and the octopus cable. Each scheme can be tailored to suit individual needs, and specific alternatives are shown in later figures.

Figure 98  
Cabling to the data equipment

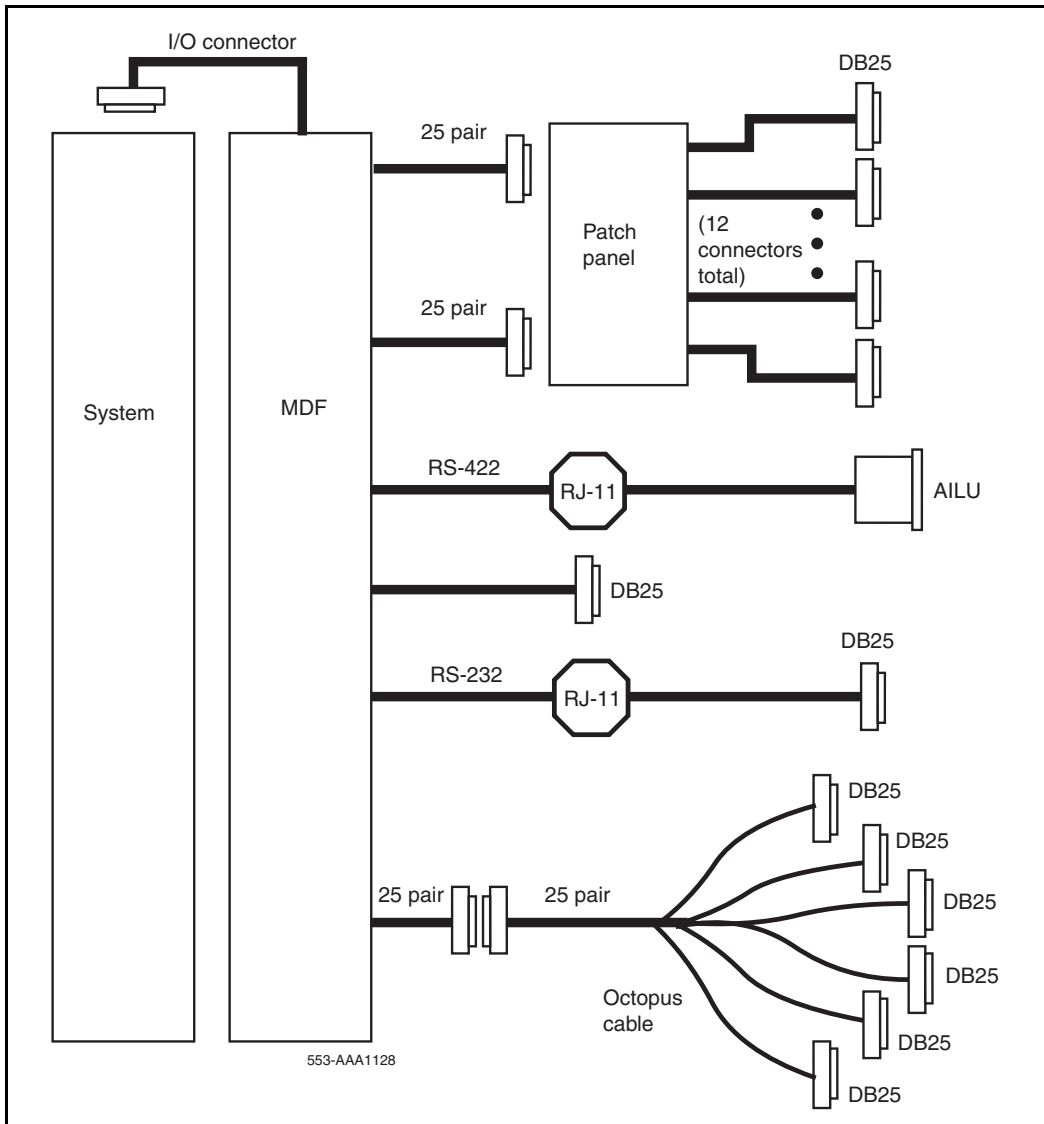


Figure 99 shows a connection through an RJ-11 or RJ-45 jack located at the data station. It is recommended that four wires be used similarly to the AIM drop when using the RJ-11 jack. Another cable is required to convert the RJ-11 or RJ-45 into DB25.

**Note:** It is necessary to turn over Receive Data and Send Data between the DAC and the AILU. This is done on the TN at the MDF.

**Figure 99**  
**RJ-11 or RJ-45 jacks**

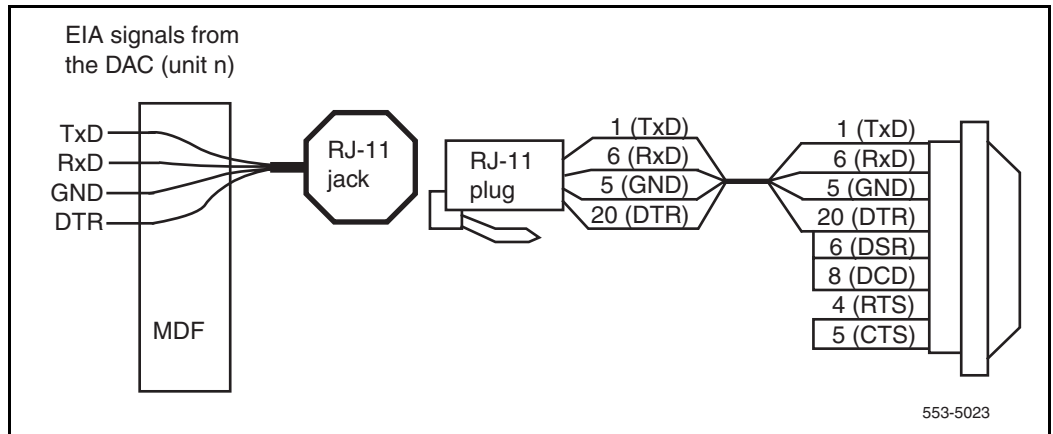
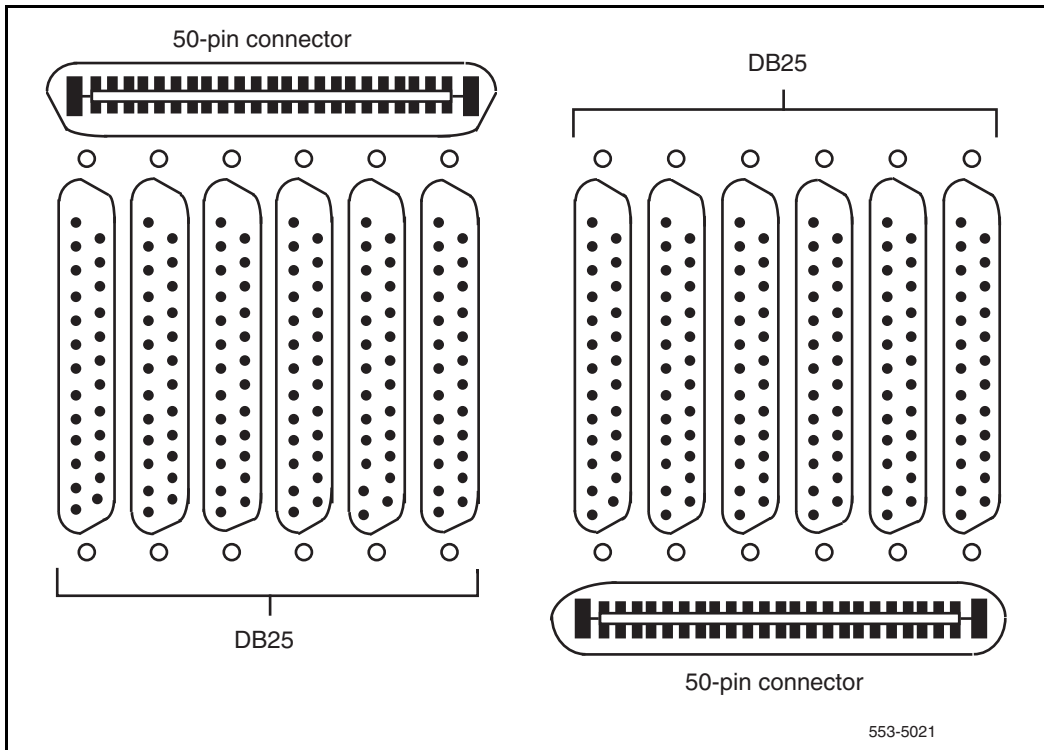


Figure 100 on [page 512](#) illustrates the patch panel. RS-232-C cables are used to connect the data equipment to the patch panel. This particular panel shows two 50-pin connectors into twelve DB25. The signals from the MDF travel on 25-pair cables, terminating at the patch panel.

**Note:** Use patch panels that follow the pinout of the DAC.

Figure 101 on [page 513](#) describes an octopus cabling scheme. This cable replaces the combined patch panel and RS-232-C cabling scheme. The 25-pair cable is split into six RS-232-C male or female connectors. This allows direct connections to the data equipment from the I/O panel. The octopus cable allows for the maximum segregation of the voice signals that might otherwise be present within the same 25-pair cable.

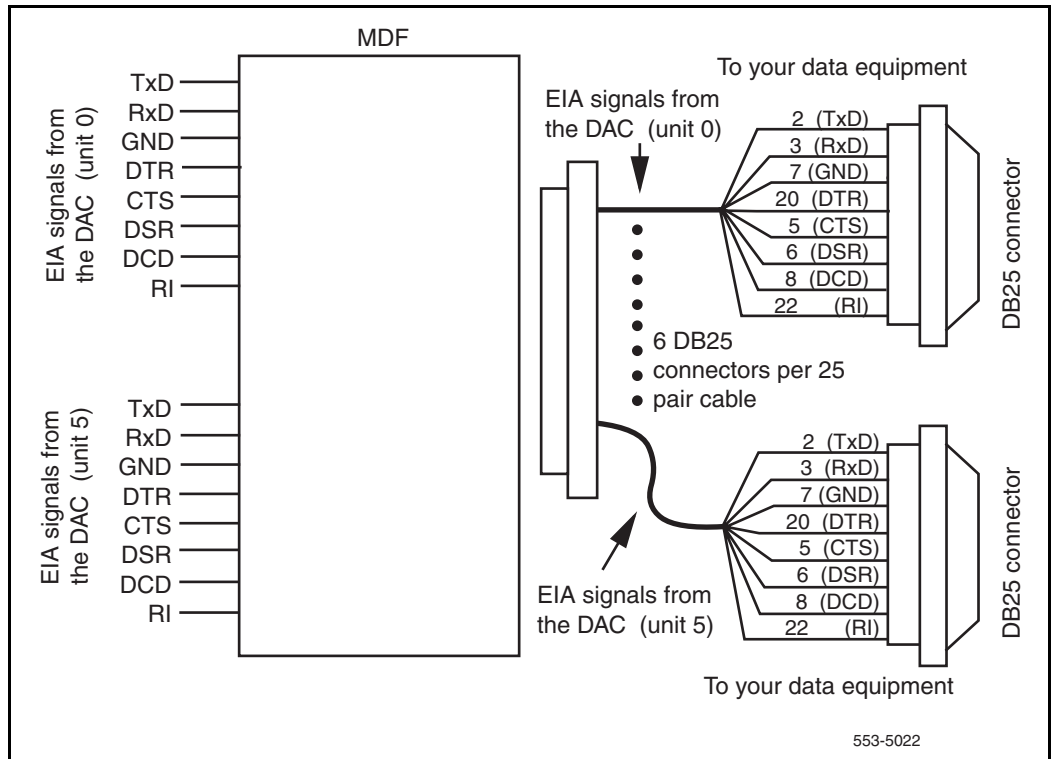
Figure 100  
Patch panel layout



**Note:** Use an octopus cable that follows the pinout of the DAC, such as QCAD318A (female) and QCAD319A (male), in conjunction with a 50-pin female-to-female gender converter.



**Figure 101**  
**Octopus cabling**



## Backplane pinout and signaling

Two 40-pin, and two 20-pin edge connectors connect the card to the backplane. The detailed pinout configurations are listed in Tables 170 and 171.

**Table 170**  
**RS-232-C and RS-422 pinouts for first three DAC ports (Part 1 of 2)**

I/O cable			Unit no.	RS-232-C		RS-422 Signal	Patch pair or octopus
Pair	Pin	Pair color		Signal	Pin no.		
1T	26	W-BL	UNIT 0	TD0	2	RDA0	
1R	1	BL-W		RD0	3	RDB0	
2T	27	W-O		DTR0	20	SDA0	
2R	2	O-W		GND0	7	SDB0	Connector
3T	28	W-G		DCD0	8		1
3R	3	G-W		DSR0	6		
4T	29	W-BR		RI0	22		
4R	4	BR-W		CTS0	5		
5T	20	W-S	UNIT 1	TD1	2	RDA1	
5R	5	S-W		RD1	3	RDB1	
6T	31	R-BL		DTR1	20	SDA1	
6R	6	BL-R		GND1	7	SDB1	Connector
7T	32	R-O		DCD1	8		2

**Note 1:** The RS-232 pinout follows the standard set by the QPC723 RILC.

**Note 2:** The RS-422 pinout follows the standard set by the QPC430 AILC (first pair: Receive Data; second pair: Send Data). Receive and Send are designated with reference to the DTE; therefore, they must be turned over in the cross-connect since most DTE have first pair as Send Data and second pair as Receive Data.

**Table 170**  
**RS-232-C and RS-422 pinouts for first three DAC ports (Part 2 of 2)**

I/O cable			Unit no.	RS-232-C		RS-422 Signal	Patch pair or octopus
Pair	Pin	Pair color		Signal	Pin no.		
7R	7	O-R		DSR1	6		
8T	33	R-G		RI1	22		
8R	8	G-R		CTS1	5		
9T	34	R-BR	UNIT 2	TD2	2	RDA2	
9R	9	BR-R		RD2	3	RDB2	
10T	35	R-S		DTR2	20	SDA2	
10R	10	S-R		GND2	7	SDB2	Connector
11T	36	BK-BL		DCD2	8		3
11R	11	BL-BK		DSR2	6		
12T	37	BK-O		RI2	22		
12R	12	O-BK		CTS2	5		

**Note 1:** The RS-232 pinout follows the standard set by the QPC723 RILC.

**Note 2:** The RS-422 pinout follows the standard set by the QPC430 AILC (first pair: Receive Data; second pair: Send Data). Receive and Send are designated with reference to the DTE; therefore, they must be turned over in the cross-connect since most DTE have first pair as Send Data and second pair as Receive Data.

**Table 171**  
**RS-232-C and RS-422 pinouts for last three DAC ports (Part 1 of 2)**

I/O cable			Unit no.	RS-232-C		RS-422 Signal	Patch pair or octopus
Pair	Pin	Pair color		Signal	Pin no.		
13T	38	BK-G	UNIT 3	TD3	2	RDA3	
13R	13	G-BK		RD3	3	RDB3	
14T	39	BK-BR		DTR3	20	SDA3	
14R	14	BR-BK		GND3	7	SDB3	Connector
15T	40	BK-S		DCD3	8		1
15R	15	S-BK		DSR3	6		
16T	41	Y-BL		RI3	22		
16R	16	BL-Y		CTS3	5		
17T	42	Y-O	UNIT 4	TD4	2	RDA4	
17R	17	O-Y	(Note)	RD4	3	RDB4	
18T	43	Y-G		DTR4	20	SDA4	
18R	18	G-Y		GND4	7	SDB4	Connector
19T	44	Y-BR		DCD4	8		2
19R	19	BR-Y		DSR4	6		
20T	45	Y-S		RI4	22		
20R	20	S-Y		CTS4	5		
21T	46	V-BL	UNIT 5	TD5	2	RDA5	
21R	21	BL-V	(Note)	RD5	3	RDB5	
22T	47	V-O		DTR5	20	SDA5	

**Note:** Units 4 and 5 are available when the DAC is installed in a fully wired 24-pair slot.

**Table 171**  
**RS-232-C and RS-422 pinouts for last three DAC ports (Part 2 of 2)**

I/O cable			Unit no.	RS-232-C		RS-422 Signal	Patch pair or octopus
Pair	Pin	Pair color		Signal	Pin no.		
22R	22	O-V		GND5	7	SDB5	Connector
23T	48	V-G		DCD5	8		3
23R	23	G-V		DSR5	6		
24T	49	V-BR		RI5	22		
24R	24	BR-V		CTS5	5		

**Note:** Units 4 and 5 are available when the DAC is installed in a fully wired 24-pair slot.

## Configuring the Data Access card

LD 11 must be configured to accept the DAC. The commands listed here must be answered. LD 20 prints out card information when requested. For a complete list of the service change prompts and responses, see *Software Input/Output: Administration* (553-3001-311).

### DAC administration (LD 11)

Responding R232 or R422 to the TYPE prompt in LD11 begins the prompt sequence for the DAC configuration. Responses to the following prompts are

required. The defaults are bracketed, and may be issued by Carriage Return (<CR>).

**LD 11 – Configure Data Access card. (Part 1 of 3)**

Prompt	Response	Description
REQ:	NEW CHG MOV COPY	Add, change, move or copy the unit
TYPE:	R232 R422	RS-232-C unit RS-422 unit
TN	l s c u	DAC data TN. The loop (LL) must be a superloop.
RNPG	<CR>	Ringing number pickup group (default to zero)
CLS		Class of Service allowed for the DAC.
	DTA ADD	Data Allowed Digit Display Allowed
TOV	(0) - 3	Timeout value, where:  0 = no timeout 1 = 15 minutes 2 = 30 minutes 3 = 60 minutes
OPE	(NO) YES	Operation parameter change
PAR	(SPAC) ODD EVEN MARK	SPAC = space parity ODD = odd parity EVEN = even parity MARK = mark parity
DTR	(OFF) ON	DTR settings, where:  ON = forced DTR OFF = dynamic DTR  This prompt appears only if TYPE = R232

**LD 11 – Configure Data Access card. (Part 2 of 3)**

Prompt	Response	Description
HOT	(OFF) ON	Hotline If HOT = ON, then AUTB = OFF
AUT	(ON) OFF	Automatic answer
AUTB	(ON) OFF	Autobaud Prompt appears only if HOT - OFF
BAUD	0-(7)-8	Baud rate, where: 0 = 110 1 = 150 2 = 300 3 = 600 4 = 1200 5 = 2400 6 = 4800 7 = 9600 8 = 19200  This prompt appears only if AUTB = OFF.
DCD	(ON) OFF	DCD settings, where: ON = dynamic DCD OFF = forced DCD  This prompt appears only if TYPE = R232.
PRM	(ON) OFF	Prompt mode, where: ON = prompt (Terminal) mode OFF = no prompt (Host) mode
DEM	(DCE) DTE	Data Equipment mode  This prompt appears only if TYPE = R232.

LD 11 – Configure Data Access card. (Part 3 of 3)

Prompt	Response	Description
DLNG	(ENG) FRN	Data port language, where: ENG = English FRN = Quebec French
KBD	(ON) OFF	Keyboard dialing, where: ON = enabled OFF = disabled (Hayes dialing commands will still work)
WIRE	(OFF) ON	Wire test mode, where: OFF = disabled ON = enabled
PBDO	(OFF) ON	Port busy upon DTR off, where: OFF = disabled (port busy on with DTR) ON = enabled (port busy off with DTR)  This prompt appears only if TYPE = R232 PBDO = OFF for any RS-232-C mode besides 8, or 12 If PBDO = ON, key 7 = MSB
KEY	0 SCR xxxx 1 SCR xxxx 2 TRN 3 ADL yy xxxx 4 RGA 5 SCC 0-253 6 DSP 7 MSB	Key settings Primary data DN Secondary Data DN Call Transfer Autodial Ring Again Speed Call Controller, list number Display Make Set Busy  Primary and secondary data DNs must be single appearance DNs. Feature key assignment must be as shown here.



## Printing the card parameters (LD 20)

By responding R232, R422, or DAC to the TYPE prompt in LD 20, you can print out the configured parameters for each port, or the entire DAC. This is useful to determine if any parameters have been altered during keyboard or Hayes dialing modify procedures.

**LD 20** – Print DAC parameters.

Prompt	Response	Description
REQ:	PRT LTN LUU	Print data, TN, or unit information for the unit specified
TYPE:	R232 R422 DAC	Print information for the RS-232-C, RS-422 ports, or the whole DAC
TN	l s c u	Print information for this TN, where l = loop, s = shelf, c = card, u = unit. Uploaded parameters can only be printed when a specific TN is listed.

The operation parameter printout for an RS-232 or RS-422 port is similar to the following, depending on the configuration.

**Table 172**  
**Print out example (Part 1 of 2)**

	DBASE R-232 or R-422	UPLOAD R-232 or R-422
PAR	SPAC	SPAC
DTR	ON	ON
HOT	OFF	OFF
AUT	ON	O
<b>Note:</b> The Upload parameters are printed only when a single TN is specified.		

**Table 172**  
**Print out example (Part 2 of 2)**

	<b>DBASE R-232 or R-422</b>	<b>UPLOAD R-232 or R-422</b>
AUTB	ON	ON
BAUD	9600	4800
DCD	OFF	OFF
PRM	KBD ON	KBD ON
DEM	DCE	DCE
DLNG	FRN	FRN
KBD	ON	ON
WIRE	OFF	OFF
PBDO	OFF	OFF
<b>Note:</b> The Upload parameters are printed only when a single TN is specified.		

## Connecting Apple Macintosh to the DAC

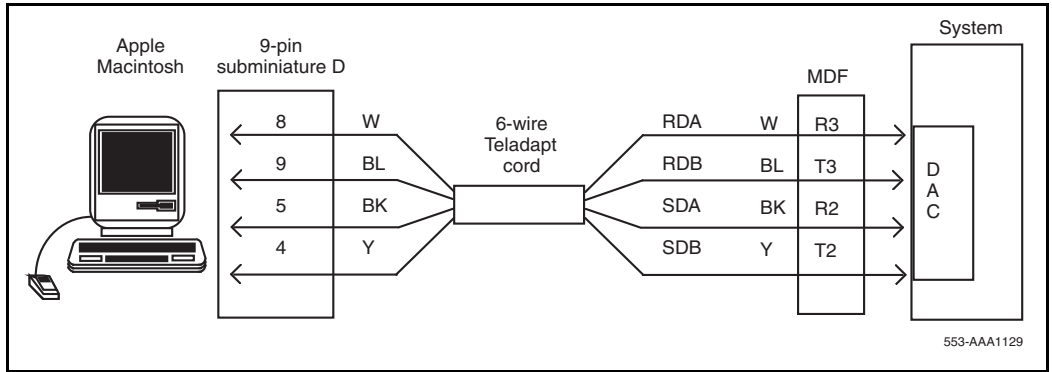
The Apple Macintosh can be connected with twisted pair wire to a port of a NT7D16 Data Access Card (DAC) to allow access to the switching capability. The Macintosh can then access local or remote terminals, personal computers, hosts, and peripherals.

Figure 102 on [page 523](#) shows the 9-pin subminiature D (DB9) connection to the Macintosh. Figure 103 on [page 523](#) shows the mini-8 DIN connection to the Macintosh.

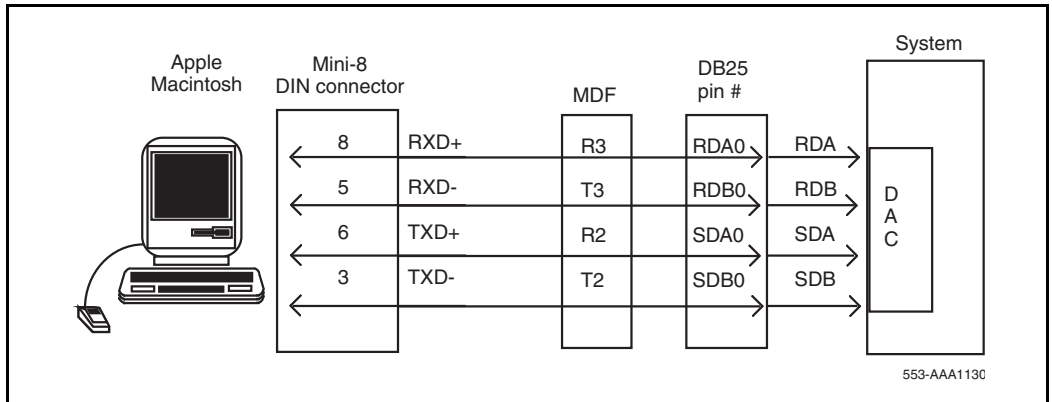
## Upgrading systems

The following explains when and how to upgrade your system to support the DAC. Ports 0, 1, 2, and 3 of the DAC will work in any standard 16-pair IPE slot (connect directly to the MDF).

**Figure 102**  
**Macintosh to DAC connection—9-pin subminiature D**



**Figure 103**  
**Macintosh to DAC connection—mini-8 DIN**



## Large System and CS 1000M HG upgrade

The DAC can be installed directly into slots 0, 4, 8, and 12 with no cabling changes. If other slots are required, the upgrade must be made. Follow this procedure to upgrade your cabling. You can upgrade the cabling segment-by-segment, or the entire module at one time.

**Note 1:** Four NT8D81AA cable/filter assemblies are required to upgrade the entire module, one assembly per segment.

**Note 2:** Cables are designated by the letter of the I/O panel cutout where the 50-pin cable connector is attached. The 20-pin connectors are labeled 1, 2, and 3.

**Note 3:** The locations for the cable connectors are designated by the slot number (L0-L9), and the shroud row (1, 2, and 3).

### Segment 0

- 1 Leave cable A as is in slot L0.
- 2 Move cable end B-3 to L1-3.
- 3 Remove cable C from the backplane and connect ends C-1, C-2, and C-3 to L2-1, L2-2, and L2-3.
- 4 Add cable D to the I/O panel by connecting ends D-1, D-2, and D-3 to L3-1, L3-2, and L3-3.

### Segment 1

- 1 Leave cable E as is in slot L4.
- 2 Move cable end F-3 to L5-3.
- 3 Remove cable G from the backplane and connect ends G-1, G-2, and G-3 to L6-1, L6-2, and L6-3.
- 4 Add cable H to the I/O panel by connecting ends H-1, H-2, and H-3 to L7-1, L7-2, and L7-3.

**Segment 2**

- 1 Leave cable K as is in slot L8.
- 2 Move cable end L-3 to L9-3.
- 3 Remove cable M from the backplane and connect ends M-1, M-2, and M-3 to L10-1, L10-2, and L10-3.
- 4 Add cable N to the I/O panel by connecting ends N-1, N-2, and N-3 to L11-1, L11-2, and L11-3.

**Segment 3**

- 1 Leave cable R as is in slot L12.
- 2 Move cable end S-3 to L13-3.
- 3 Remove cable T from the backplane and connect ends T-1, T-2, and T-3 to L14-1, L14-2, and L14-3.
- 4 Add cable U to the I/O panel by connecting ends U-1, U-2, and U-3 to L15-1, L15-2, and L15-3.

Be sure to re-label the MDF to show that the module has been upgraded to provide one cable for each IPE slot. The resulting backplane and cable arrangement should look like this:

Backplane slot-connector	I/O panel cable position
L0	A
L1	B
L2	C
L3	D (new cable)
L4	E
L5	F
L6	G
L7	H (new cable)
L8	K
L9	L
L10	M
L11	N (new cable)
L12	R
L13	S
L14	T
L15	U (new cable)

---

# NT8D02 and NTDK16 Digital Line cards

---

## Contents

This section contains information on the following topics:

Introduction . . . . .	527
Physical description . . . . .	528
Functional description . . . . .	530
Electrical specifications . . . . .	536
Connector pin assignments . . . . .	539
Configuration . . . . .	541

## Introduction

### **IMPORTANT!**

The NT8D02 digital line card is supported in CS 1000S, CS 1000M, and Meridian 1.

The NTDK16 digital line card is supported **ONLY** in the Chassis system.

The Digital Line card is a voice and data communication link between the system and Digital Telephones. It supports voice only or simultaneous voice and data service over a single twisted pair of standard telephone wiring.

When a digital telephone is equipped with the data option, an asynchronous or synchronous terminal or personal computer can be connected to the system through the digital telephone.

The Digital Line card provides 16 voice and 16 data communication links.

## NT8D02 Digital Line card

The 32 port NT8D02 Digital Line card is supported in the MG 1000S and MG 1000S Expansion.

You can install this card in any IPE slot.

## NTDK16 Digital Line card

The NTDK16 is a 48 port card supported only in the Chassis system. It is based on the NT8D02 Digital Line card and is functionally equivalent to three NT8D02s, and configured as cards 4, 5, and 6 in the main chassis. It uses A94 Digital Line Interface chips (DLIC) to provide the interface between the Digital sets and the system.

The NTDK16 Digital Line card can only be installed in slot 4 of the main chassis which is slotted to prevent accidental insertion of other cards.

## Physical description

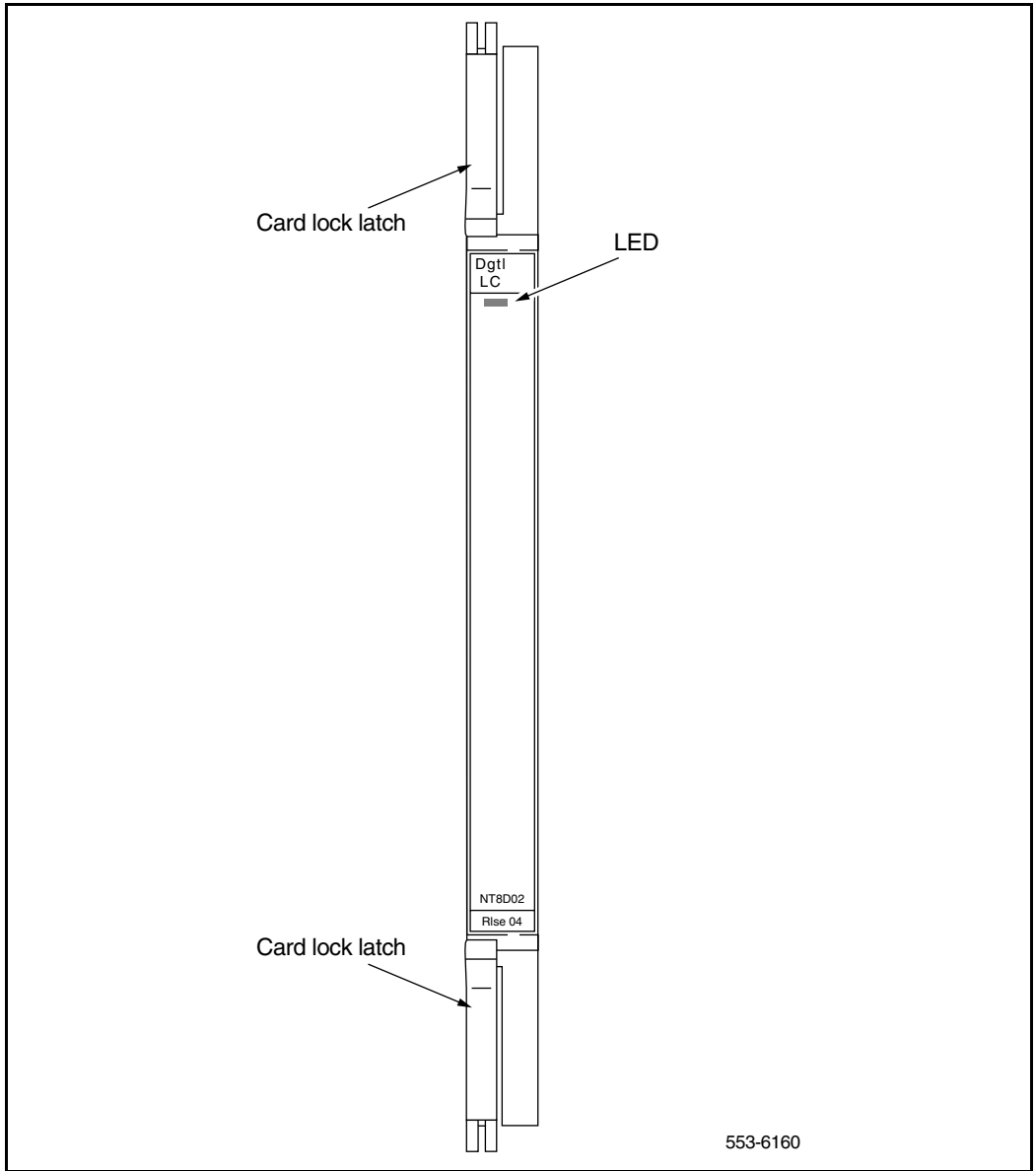
The Digital Line card circuitry is mounted on a 31.75 cm by 25.40 cm (12.5 in. by 10 in.) printed circuit board. The NT8D02 is a double-sided PCB, whereas the NTDK16 is 4 layers, but standard thickness. Both cards connect to the backplane through a 120-pin or 160-pin edge connector.

The faceplate of the NT8D02 Digital Line card is equipped with a red LED that lights when the card is disabled. See Figure 104 on [page 529](#). When the card is installed, the LED remains lit for two to five seconds as a self-test runs. If the self-test completes successfully, the LED flashes three times and remains lit until the card is configured and enabled in software, then the LED goes out. If the LED continually flashes or remains weakly lit, replace the card.

**Note:** The NTDK16AA has one LED. This LED shows the status of Card 4. The NTDK16BA has three LEDs. These LEDs show the status of Cards 4, 5, and 6 configured on the NTDK16.



Figure 104  
Digital line card – faceplate



553-6160

## Functional description

### NT8D02 Digital Line card

The NT8D02 digital line card is equipped with 16 identical units. Each unit provides a multiplexed voice, data, and signaling path to and from digital apparatus over a 2-wire full duplex 512 kHz time compression multiplexed (TCM) digital link. Each digital telephone and associated data terminal is assigned a separate terminal number (TN) in the system database, for a total of 32 addressable ports per card.

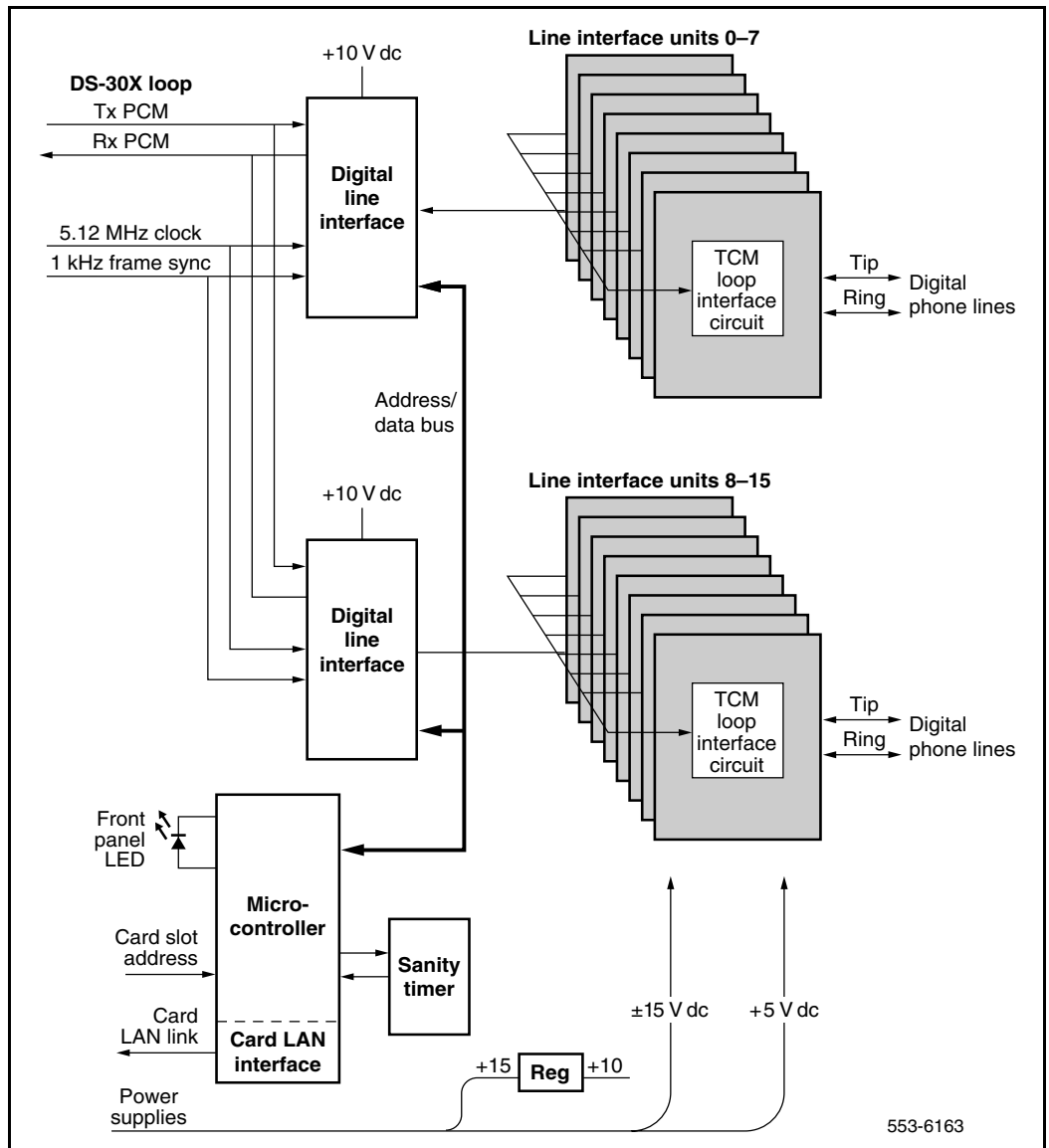
The NT8D02 Digital Line card is equipped with 16 identical digital line interfaces. Each interface provides a multiplexed voice, data, and signaling path to and from a digital terminal (telephone) over a 2-wire full duplex 512 kHz Time Compression Multiplexed (TCM) digital link. Each digital telephone and associated data terminal is assigned a separate Terminal Number (TN) in the system database, giving a total of 32 addressable units per card. The digital line card supports Nortel' Meridian Digital Telephone.

The digital line card contains a microprocessor that provides the following functions:

- self-identification
- self-test
- control of card operation
- status report to the controller
- maintenance diagnostics

Figure 105 on [page 531](#) shows a block diagram of the major functions contained on the NT8D02 Digital Line card. Each of these functions is described on the following pages.

**Figure 105**  
**Digital line card – block diagram**



## NTDK16 Digital Line card

The NTDK16 digital line card is equipped with 48 identical units. Each unit provides a multiplexed voice, data, and signaling path to and from digital apparatus over a 2-wire full duplex 512 kHz time compression multiplexed (TCM) digital link. Each digital telephone and associated data terminal is assigned a separate terminal number (TN) in the system database, for a total of 96 addressable ports per card. Refer to Figure 106 on [page 533](#).

The NTDK16 digital line card contains a microprocessor that provides the following functions:

- self-identification
- self-test
- control of card operation
- status report to the controller
- maintenance diagnostics

The card also provides:

- Ability to support Digital sets and the Digital Console M2250
- Provides a serial link (Card LAN) for status report and maintenance.
- Supports loop lengths up to 3500 ft. (1.0 km) using 24 AWG wire.
- Interface between three DS30X loops and 48 TCM lines.

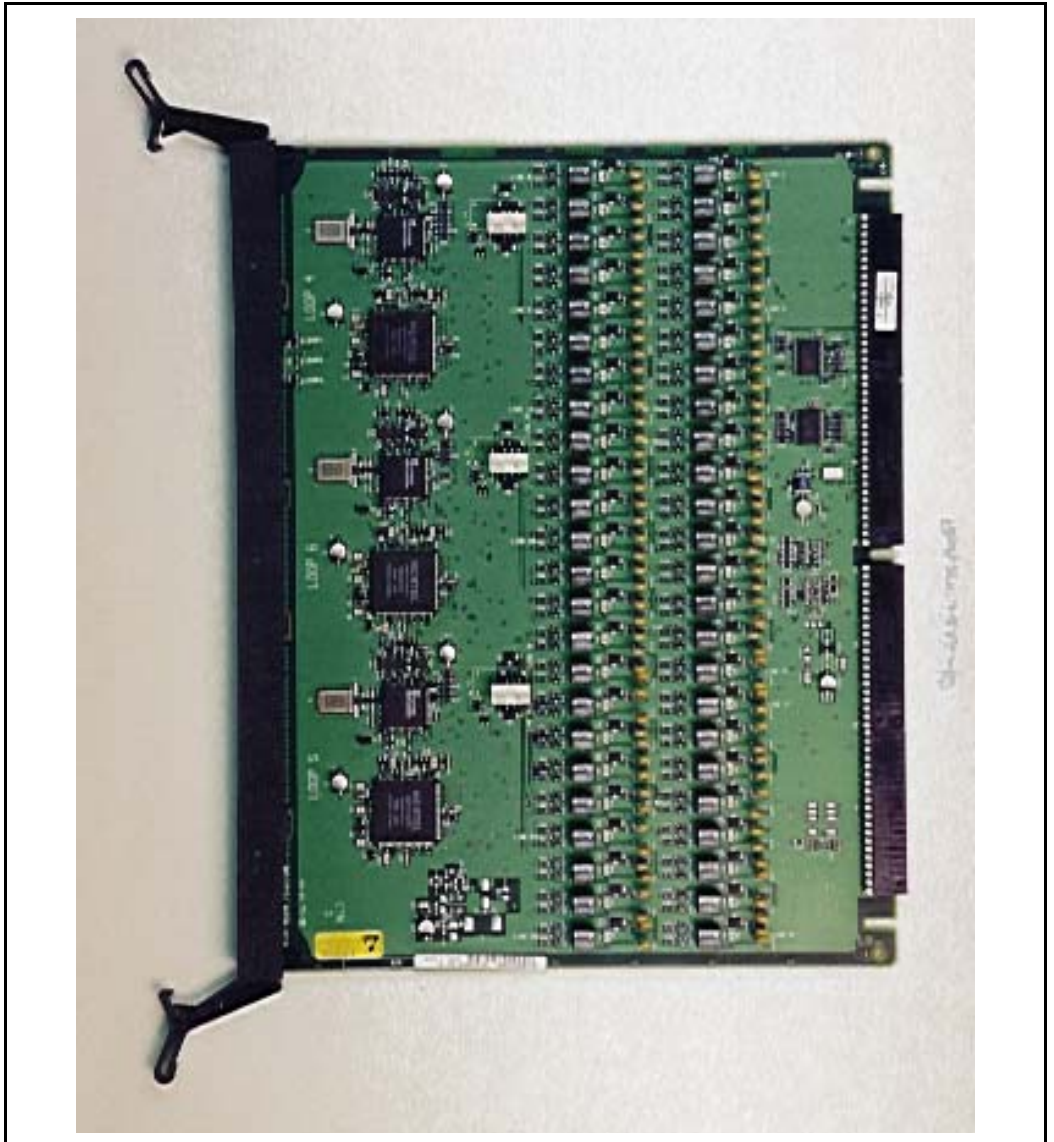
## Card interfaces

The digital line card passes voice, data, and signaling over DS-30X loops and maintenance data over the card LAN link. These interfaces are discussed in detail in the section “Intelligent Peripheral Equipment” on [page 32](#).

## Digital line interfaces

The digital line interface contains two Digital Line Interface Circuits (DLIC). Each digital line interface circuit provides eight identical, individually configurable voice and data interfaces to eight digital telephone lines. These

Figure 106  
NTDK16 DLC



lines carry multiplexed PCM voice, data, and signaling information as TCM loops.

The purpose of each digital line interface circuit is to de-multiplex data from the DS-30X Tx channel into eight integrated voice and data bitstreams. The circuits then transmit those bitstreams as Bi-Polar Return to Zero, Alternate Mark Inversion (BPRZ-AMI) data to the eight TCM loops. They also perform the opposite action: they receive eight BPRZ-AMI bitstreams from the TCM loops and multiplex them onto the DS-30X Rx channel. The two digital line interface circuits perform the multiplexing and de-multiplexing functions for the 16 digital telephone lines.

The digital line interface circuits also contain signaling and control circuits that establish, supervise, and take down call connections. These circuits work with the on-card microcontroller to operate the digital line interface circuits during calls. The circuits receive outgoing call signaling messages from the Call Server and return incoming call status information to the Call Server over the DS-30X network loop.

### **TCM loop interface circuit**

Each digital telephone line terminates on the NT8D02 Digital Line card at a TCM loop interface circuit. The circuit provides transformer coupling and foreign voltage protection between the TCM loop and the digital line interface circuit. It also provides battery voltage for the digital telephone.

To prevent undesirable side effects from occurring when the TCM loop interface cannot provide the proper signals on the digital phone line, the card microcontroller can remove the  $\pm 15$  V dc power supply from the TCM loop interfaces. This happens when either the microcontroller gets a command from the NT8D01 controller card to shut down the channel, or the digital line card detects a loss of the 1 KHz frame synchronization signal. The  $\pm 15$  V dc power supply signal is removed from all 16 TCM loop interface units at the same time.

Each TCM loop interface circuit can service loops up to 3500 ft. in length when using 24-gauge wire. They support a maximum ac signal loss of 15.5 dB at 256 KHz and a maximum dc loop resistance of 210 ohms.

## Card control functions

Control functions are provided by a microcontroller and a Card LAN link on the digital line card. A sanity timer is provided to automatically reset the card if the microcontroller stops functioning for any reason.

### Microcontroller

The NT8D02 Digital Line card contains a microcontroller that controls the internal operation of the card and the serial card LAN link to the controller card. The microcontroller controls the following:

- reporting to the Call Server through the card LAN link:
  - card identification (card type, vintage, and serial number)
  - firmware version
  - self-test status
  - programmed configuration status
- receipt and implementation of card configuration:
  - programming of the digital line interfaces
  - enabling/disabling of individual units or entire card
  - programming of loop interface control circuits for administration of line interface unit operation
  - maintenance diagnostics

The microcontroller also controls the front panel LED when the card is enabled or disabled by instructions from the NT8D01 controller card.

### Card LAN interface

Maintenance data is exchanged with the common equipment Call Server over a dedicated asynchronous serial network called the Card LAN link.

### Sanity timer

The NT8D02 Digital Line card also contains a sanity timer that resets the microcontroller if program control is lost. The microcontroller must service

the sanity timer every 1.2 seconds. If the timer is not properly serviced, it times out and causes the microcontroller to be hardware reset.

## **Circuit power**

The +15 V dc input is regulated down to +10 V dc for use by the digital line interface circuits. The  $\pm 15.0$  V dc inputs to the card are used to power the loop interface circuits.

## **Electrical specifications**

This section lists the electrical characteristics of the NT8D02 Digital Line card.



## Digital line interface specifications

Table 173 provides a technical summary of the digital line cards.

**Table 173**  
**NT8D02/NTDK16 Digital Line card technical summary**

Characteristics	NT8D02 DLC description	NTDK16BA DLC description	NTDK16AA DLC description
<b>Units per card</b>	16 voice, 16 data	48 voice, 48 data	48 voice, 48 data
<b>Impedance</b>	100 Ohm j/b ohm	100 Ohm j/b ohm	100 Ohm j/b ohm
<b>Loop limits</b>	30 m (100 ft) to 915 m (3000 ft) with 24 AWG PVC cable (+15 V DC at 80 mA)	30 m (100 ft) to 915 m (3000 ft) with 24 AWG PVC cable ( $\pm 15$ V DC at 80 mA)	30 m (100 ft) to 915 m (3000 ft) with 24 AWG PVC cable ( $\pm 15$ V DC at 80 mA)
	0 to 1070 m (3500 ft) with 24 AWG PVC cable ( $\pm 15$ V DC at 80 mA)	0 to 1070 m (3500 ft) with 24 AWG PVC cable ( $\pm 15$ V DC at 80 mA)	0 to 1070 m (3500 ft) with 24 AWG PVC cable ( $\pm 15$ V DC at 80 mA)
<b>Line rate</b>	512 kbps $\pm$ 100 ppm	512 kbps $\pm$ 100 ppm	512 kbps $\pm$ 100 ppm
<b>Power supply</b>	+ 5 V DC $\pm 15$ V DC +10 V DC	+ 5 V DC $\pm 15$ V DC	+ 5 V DC $\pm 15$ V DC +8 V DC
<b>Transmitter output voltage:</b>			
• successive "1" bits	+1.5 $\pm$ 0.15 V and -1.5 $\pm$ 0.15 V		
• "0" bits	0 $\pm$ 50 mV		
<b>Additional circuitry</b>	Not applicable	Not applicable	Power Failure Transfer Control Ring Sync.

## Power requirements

The digital line card needs  $\pm 15\text{V}$  DC over each loop at a maximum current of 80 mA. It requires +15V, -15V, and +5V from the backplane. The line feed interface can supply power to one loop of varying length up to 1070 m (3500 ft) using 24 AWG wire with a maximum allowable AC signal loss of 15.5 dB at 256 kHz, and a maximum DC loop resistance of 210 ohms; 26 AWG wire is limited to 745 m (2450 ft).

**Table 174**  
**Digital line card—power required**

Voltage	Current (max.)
$\pm 5.0\text{ V dc}$	150 mA
+15.0 V dc	1.6 Amp
-15.0 V dc	1.3 Amp

## Foreign and surge voltage protections

In-circuit protection against power line crosses or lightning is not provided on the NT8D02 Digital Line card. The NT8D02 Digital Line card does, however, have protection against accidental shorts to  $-52\text{ V dc}$  analog lines.

When the card is used to service off-premise telephones, primary and secondary Main Distribution Frame (MDF) protection must be installed.

Off-premise telephones served by cable pairs routed through the central office, or crossing a public right-of-way, can be subject to a requirement for on-card protection, and MDF protectors may not be acceptable. Check local regulations before providing such service.

## Environmental specifications

Table 175 shows the environmental specifications of the card.

**Table 175**  
**Digital line card – environmental specifications**

Parameter	Specifications
Operating temperature	0° to +60° C (+32 to +140° F), ambient
Operating humidity	5 to 95% RH (non-condensing)
Storage temperature	-40° to +70° C (-40° to +158° F)

## Connector pin assignments

Table 176 shows the I/O pin designations at the backplane connector, which is arranged as an 80-row by 2-column array of pins. Normally, these pin positions are cabled to 50-pin connectors at the I/O panel in the rear of each module for connection with 25-pair cables to the MDF.

The information in Table 176 is provided as a reference and diagnostic aid at the backplane, since the cabling arrangement can vary at the I/O panel. See *Communication Server 1000M and Meridian 1: Large System Installation and Configuration* (553-3021-210) for cable pinout information for the I/O panel.

**Table 176**  
**NT8D02 Digital Line card – backplane pinouts (Part 1 of 2)**

Backplane Pinout*	Lead Designations	Backplane Pinout*	Lead Designations
12A	Line 0, Ring	12B	Line 0, Tip
13A	Line 1, Ring	13B	Line 1, Tip
14A	Line 2, Ring	14B	Line 2, Tip
15A	Line 3, Ring	15B	Line 3, Tip
* These pinouts apply to both the NT8D37 and NT8D11 backplanes			

**Table 176**  
**NT8D02 Digital Line card – backplane pinouts (Part 2 of 2)**

<b>Backplane Pinout*</b>	<b>Lead Designations</b>	<b>Backplane Pinout*</b>	<b>Lead Designations</b>
16A	Line 4, Ring	16B	Line 4, Tip
17A	Line 5, Ring	17B	Line 5, Tip
18A	Line 6, Ring	18B	Line 6, Tip
19A	Line 7, Ring	19B	Line 7, Tip
62A	Line 8, Ring	62B	Line 8, Tip
63A	Line 9, Ring	63B	Line 9, Tip
64A	Line 10, Ring	64B	Line 10, Tip
65A	Line 11, Ring	65B	Line 11, Tip
66A	Line 12, Ring	66B	Line 12, Tip
67A	Line 13, Ring	67B	Line 13, Tip
68A	Line 14, Ring	68B	Line 14, Tip
69A	Line 15, Ring	69B	Line 15, Tip
* These pinouts apply to both the NT8D37 and NT8D11 backplanes			

## Configuration

This section outlines the procedures for configuring the switches and jumpers on the NT8D02 Digital Line card and configuring the system software to properly recognize the card. Figure 107 on [page 542](#) shows where the switches and jumper blocks are located on this board.

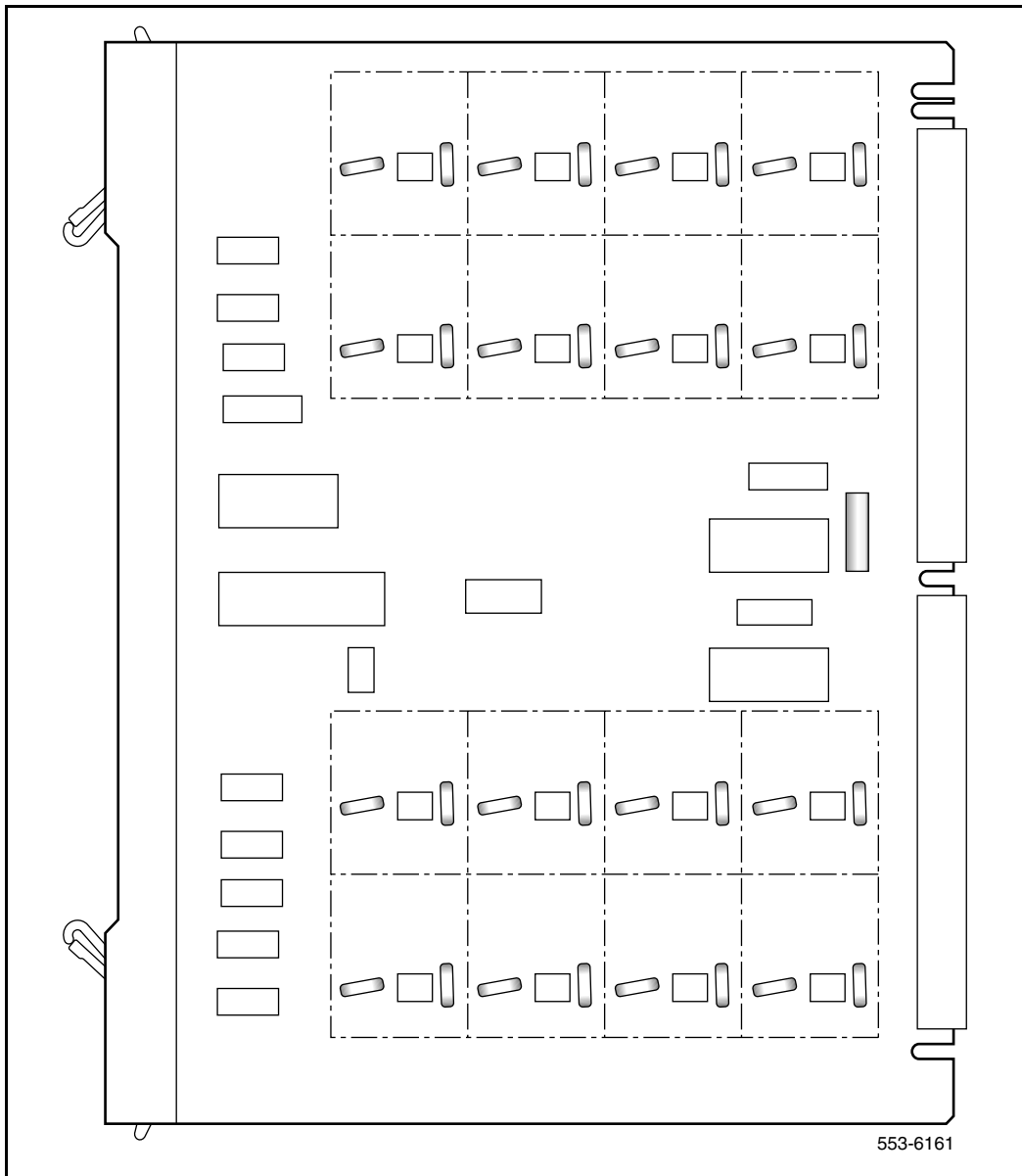
### Jumper and switch settings

The NT8D02 Digital Line card has no user-configurable jumpers or switches. The card derives its address from its position in the backplane and reports that information back to the Call Server through the LAN Link interface.

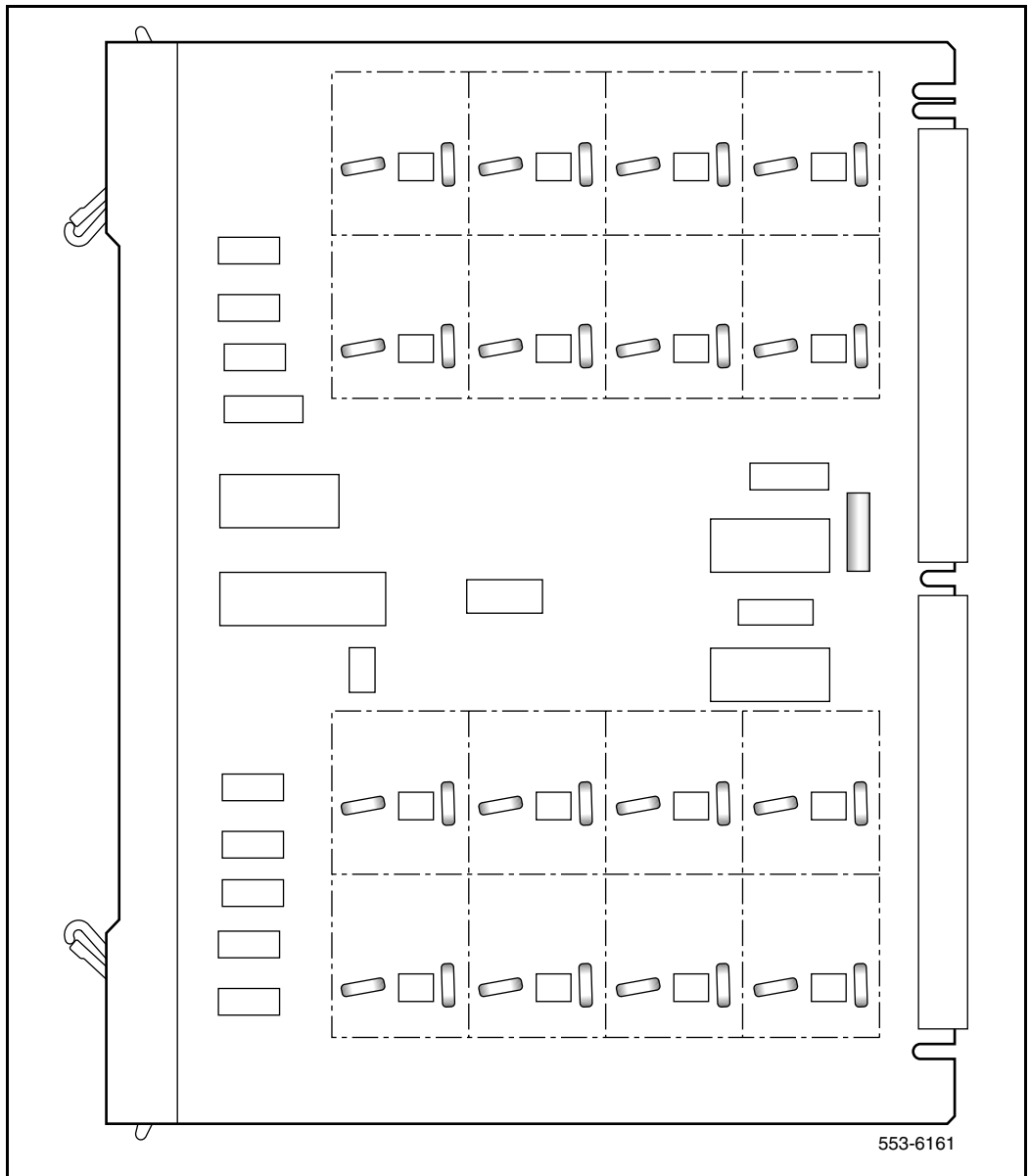
### Software service changes

Voice and data ports are configured using the Meridian Digital Telephone Administration program LD 11. See the *Software Input/Output: Administration* (553-3001-311) for LD 11 service change instructions.

**Figure 107**  
**Digital line card – jumper block and switch locations**



**Figure 108**  
**Digital line card – jumper block and switch locations**







---

# NT8D03 Analog Line card

---

## Overview

The NT8D03 Analog Line card provides an interface for up to 16 analog (500/2500-type) telephones. It is equipped with an 8051-family microprocessor that performs the following functions:

- control of card operation
- card identification
- self-test
- status reporting to the controller
- maintenance diagnostics

You can install this card in any IPE slot.

*Note:* A maximum of four NT8D03 Analog Line cards can be installed in each MG 1000S. A maximum of four NT8D03 Analog Line cards can be installed in each MG 1000S Expansion.



---

# NT8D09 Analog Message Waiting Line card

---

## Contents

This section contains information on the following topics:

<a href="#">Introduction</a> . . . . .	547
<a href="#">Physical description</a> . . . . .	549
<a href="#">Functional description</a> . . . . .	549
<a href="#">Connector pin assignments</a> . . . . .	558
<a href="#">Configuration</a> . . . . .	561

## Introduction

The NT8D09 Analog Message Waiting Line card is an IPE line card that can be installed in the NT8D37 IPE module.

The NT8D09 Analog Message Waiting Line card ( $\mu$ -Law) provides talk battery and signaling for up to 16 regular 2-wire common battery analog (500/2500-type) telephones and key telephone equipment, with the Message Waiting lamp feature.

The NT8D09 Analog Message Waiting Line card is functionally identical to the NT8D03 Analog Line card, except it can also connect a high-voltage, low-current feed to each line to light the message waiting lamp on telephones equipped with the Message Waiting feature.

The analog message waiting line card mounts in any IPE slot.

**Note:** A maximum of four NT8D09 Analog Message Waiting Line cards per MG 1000S and four NT8D09 Analog Message Waiting Line cards per MG 1000S Expansion are supported.

Cards later than vintage NT8D09AK support  $\mu$ -Law and A-Law companding, and provide a 2 dB transmission profile change. The transmission change improves performance on long lines, particularly for lines used outside of a single-building environment.

The NT8D09 Analog Message Waiting Line card supports 56K modem operation.



**CAUTION**

**Damage to Equipment**

If a modem is connected to a port on the message waiting line card, that port should not be defined in software (LD 10) as having message waiting capabilities. Otherwise, the modem will be damaged.

The NT8D09 Analog Message Waiting Line card interfaces to and is compatible with the equipment listed in Table 177.

**Table 177**  
**NT8D09 Analog Message Waiting Line card application and compatibility (Part 1 of 2)**

Equipment	Specifications
<b>500-type rotary dial sets (or equivalent):</b>	
dial speed	8.0 to 12.5 pps
percent break	58 to 70%
interdigital time	150 ms
<b>2500-type Digitone sets (or equivalent):</b>	
frequency accuracy	$\pm$ 1.5%
pulse duration	40 ms

**Table 177**  
**NT8D09 Analog Message Waiting Line card application and compatibility (Part 2 of 2) (Continued)**

<b>Equipment</b>	<b>Specifications</b>
interdigital time	40 ms
speed	12.5 digits/s

## Physical description

The circuitry is mounted on a 31.75 cm. by 25.40 cm (12.5 in. by 10 in.) printed circuit board.

The NT8D09 Analog Message Waiting Line card circuits connects to the backplane through a 160-pin connector. The backplane is cabled to a connector in the bottom of the cabinet which is cabled to the cross-connect terminal (Main Distribution Frame) through 25-pair cables. Station apparatus then connects to the card at the cross-connect terminal.

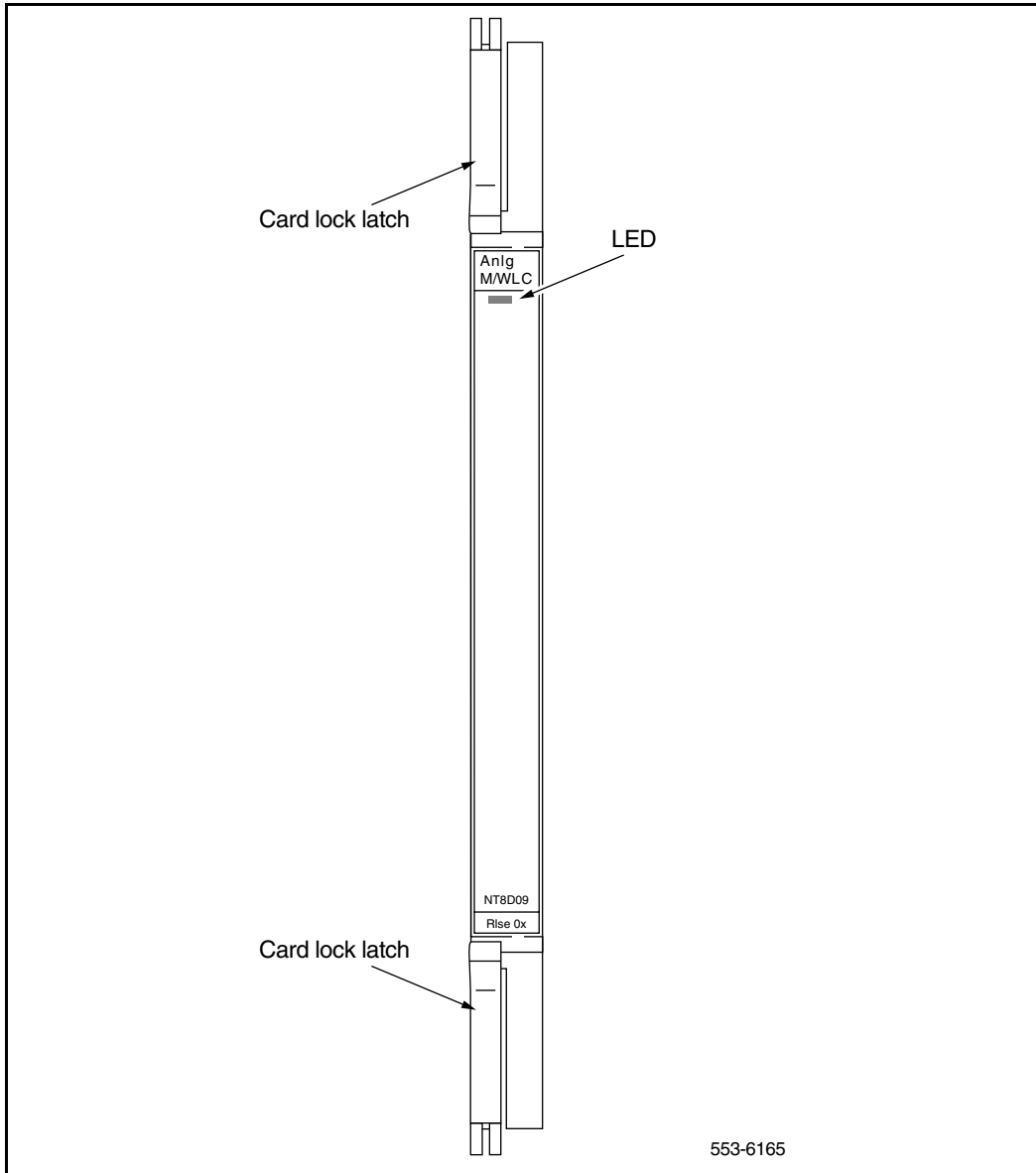
The faceplate of the NT8D09 Analog Message Waiting Line card is equipped with a red LED which lights when the card is disabled (see Figure 109 on [page 550](#)). At power-up, the LED flashes as the analog line card runs a self-test. If the test completes successfully, the card is automatically enabled (if it is configured in software) and the LED goes out.

## Functional description

The **NT8D09** Analog Message Waiting Line card contains a microprocessor that provides the following functions:

- self-identification
- self-test
- control of card operation
- status report to the controller
- maintenance diagnostics

Figure 109  
Analog message waiting line card – faceplate

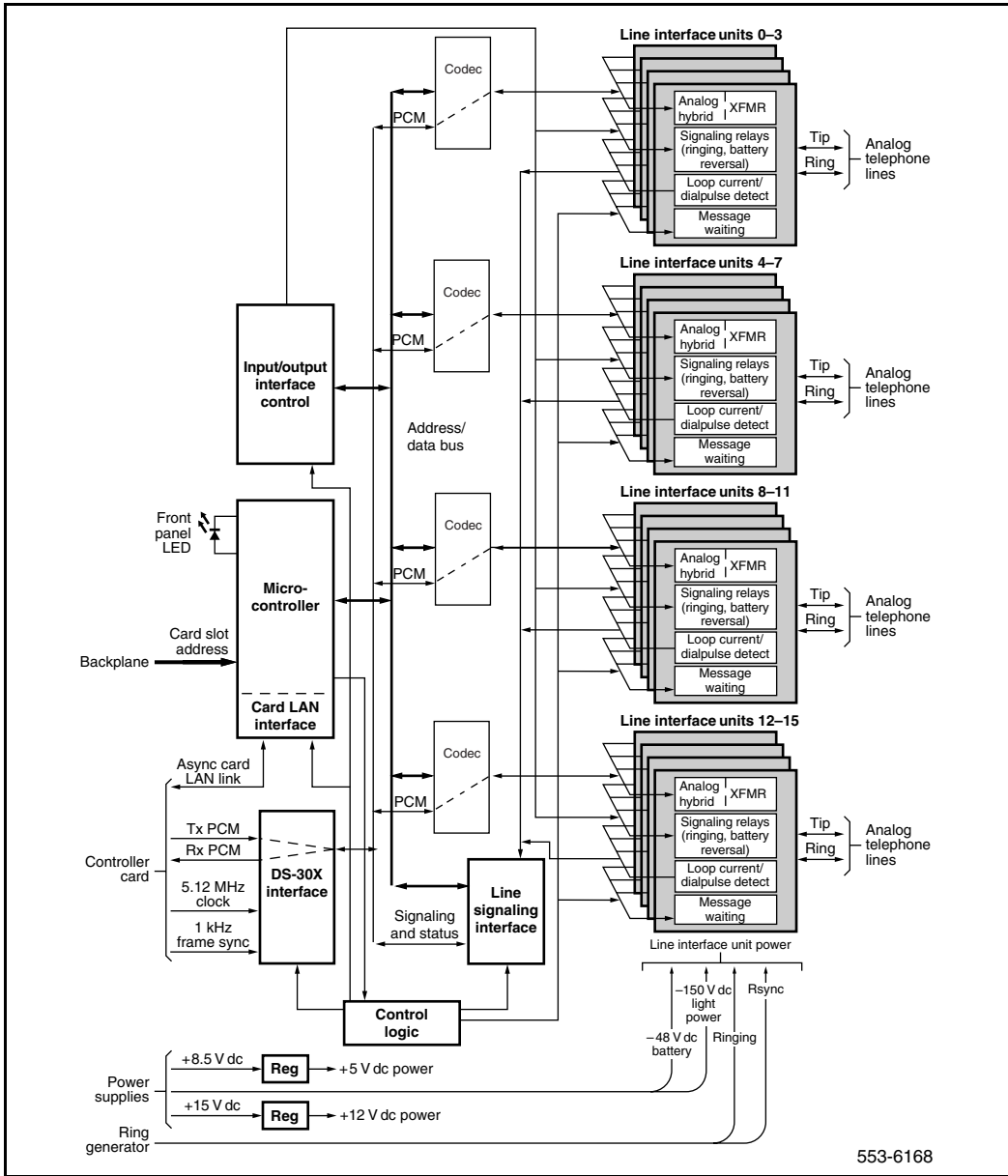


The **NT8D09** Analog Message Waiting Line card also provides:

- 600 ohms balanced terminating impedance
- analog-to-digital and digital-to-analog conversion of transmission and reception signals for 16 audio phone lines
- transmission and reception of Scan and Signaling Device (SSD) signaling messages over a DS-30X signaling channel in A10 format
- on-hook/off-hook status and switchhook flash detection
- 20 Hz ringing signal connection and automatic disconnection when the station goes off-hook
- synchronization for connecting and disconnecting the ringing signal to zero crossing of ringing voltage
- loopback of SSD messages and Pulse Code Modulation (PCM) signals for diagnostic purposes
- correct initialization of all features at power-up
- direct reporting of digit dialed (500-type telephones) by collecting dial pulses
- connection of  $-150$  V dc at 1 Hz to activate message waiting lamps
- lamp status detection
- disabling and enabling of selected units for maintenance

Figure 110 on [page 552](#) shows a block diagram of the major functions contained on the analog message waiting line card. Each of these functions are described in the following sections.

Figure 110  
Analog message waiting line card – block diagram



553-6168



## Card interfaces

The analog message waiting line card passes voice and signaling data over DS-30X loops and maintenance data over the card LAN link. These interfaces are discussed in “Intelligent Peripheral Equipment” on [page 32](#).

## Line interface units

The analog message waiting line card contains 16 identical and independently configurable line interface units (also referred to as circuits). Each unit provides 600-ohm impedance matching and a balance network in a signal transformer/analog hybrid circuit. Circuits are also provided in each unit to apply the ringing voltage onto the line synchronized to the ringing current zero crossing. Signal detection circuits monitor on-hook/off-hook status and switchhook flash detection. Four codecs are provided to perform A/D and D/A conversion of line analog voiceband signals to digital PCM signals. Each CODEC supports four line interface units. The following features are common to all units on the card:

- Transmission and reception of Scan and Signaling Device (SSD) signaling messages over a DS30X signaling channel in A10 format.
- Loopback of SSD messages and pulse code modulation (PCM) signals for diagnostic purposes.
- Correct initialization of all features, as configured in software, at power-up.
- Direct reporting of digits dialed (500 telephones) by collecting dial pulses.
- Connection of –150 V dc at 1 Hz to activate message waiting lamps in two telephones in parallel. The two telephones must be the same type or the neon series resistor in each telephone must be 54 K ohms or greater.
- Lamp status detection (will not detect a failure of either lamp when operating in parallel).
- Disabling and enabling of selected units for maintenance.
- 40 mA to telephones with short circuit protection.

## Card control functions

Control functions are provided by the following:

- a microcontroller
- a card LAN interface
- signaling and control circuits on the analog message waiting line card

### Microcontroller

The analog message waiting line card contains a microcontroller that controls the internal operation of the card and the serial card LAN link to the controller card. The microcontroller controls the following:

- reporting to the CE CP through the card LAN link:
  - card identification (card type, vintage, and serial number)
  - firmware version
  - self-test status
  - programmed configuration status
- receipt and implementation of card configuration:
  - programming of the codecs
  - enabling/disabling of individual units or entire card
  - programming of input/output interface control circuits for administration of line interface unit operation
  - enabling/disabling of an interrupted dial tone to indicate call waiting
  - maintenance diagnostics
  - transmission loss levels

### Signaling and control

The signaling and control portion of the card provides circuits that establish, supervise, and take down call connections. These circuits work with the system CP to operate the line interface circuits during calls. The circuits receive outgoing call signaling messages from the CP and return incoming call status information over the DS-30X network loop.

## Analog line interface

### Input impedance

The impedance at tip and ring is 600 ohms with a return loss of:

- 20 dB for 200-500 Hz
- 26 dB for 500-3400 Hz

### Insertion loss

On a station line-to-line connection, the total insertion loss at 1 kHz is 6 dB  $\pm$  1 dB. This is arranged as 3.5 dB loss for analog to PCM, and 2.5 dB loss for PCM to analog.

### Frequency response

The loss values in Table 178 are measured relative to the loss at 1 kHz.

**Table 178**  
**Analog message waiting line card – frequency response**

Frequency (Hz)	Minimum (dB)	Maximum (dB)
60	20.0	—
200	0.0	5.0
300	-0.5	1.0
3000	-0.5	1.0
3200	-0.5	1.5
3400	0.0	3.0

### Message channel noise

The message channel noise C-weighted (dBrnC) on 95 percent of the connections (line to line) with both ends terminated in 600 ohms does not exceed 20 dBrnC.

Table 179 provides a technical summary of the analog message waiting line card.

**Table 179**  
**NT8D09 Analog Message Waiting Line card technical summary**

Impedance	600 ohms
Loop limit (excluding set)	1000 ohms at nominal -48 V (excluding set)
Leakage resistance	30,000 ohms
Ring trip	During silent or ringing intervals
Ringing voltage	86 V AC
Signaling	Loop start
Supervision	Normal battery conditions are continuously applied (approximately -44.5 V on ring and -2.5 V on tip at nominal -48 V battery)
Power input from backplane	-48 (can be as low as -42 for DC-powered systems), +15, -15, +8.5 V and ringing voltage; also -150 V on analog message waiting line card.
Insertion loss	6 dB $\pm$ 1 dB at 1020 Hz 3.5 dB loss for analog to PCM, 2.5 dB loss for PCM to analog

## Power requirements

Table 180 provides the power requirements for the NT8D09 Analog Message Waiting Line card.

**Table 180**  
**Power requirements**

Voltage (+/-)	Tolerance	Idle current	Active current	Max
+ 12.0 V dc	0.36 V dc	48 mA	0 mA	48 mA
+ 8.0 V dc	0.40 V dc	150 mA	8 mA	280 mA
-48.0 V dc	2.00 V dc	48 mA	40 mA	688 mA
-48.0 V dc	5.00 V dc	0 mA	10 mA (Note 1)	320 mA
86.0 V ac	5.00 V ac	0 mA	10 mA (Note 2)	160 mA
-150.0 V dc	3.00 V dc	0 mA	2 mA	32 mA
<b>Note 1:</b> Each active ringing relay requires 10 mA of battery voltage.				
<b>Note 2:</b> Reflects the current for ringing a single station set (or DN telephone). There may be as many as five ringers on each line.				

## Foreign and surge voltage protections

In-circuit protection against power line crosses or lightning is not provided on the NT8D09 Analog Message Waiting line card.

## Overload level

Signal levels exceeding +7 dBm applied to the tip and ring cause distortion in speech transmission.

## Environmental specifications

Table 181 lists the environmental specifications for the analog message waiting line card.

**Table 181**  
**Analog message waiting line card – environmental specifications**

Parameter	Specifications
Operating temperature	0° to +60° C (+32 to +140° F), ambient
Operating humidity	5 to 95% RH (non-condensing)
Storage temperature	-40° to +70° C (-40° to +158° F)

## Connector pin assignments

The analog message waiting line card brings the 16 phone lines to the IPE backplane through a 160-pin connector shroud. The backplane is cabled to the I/O panel on the rear of the module, which is then connected to the MDF by 25-pair cables.

Telephone lines from station equipment cross connect to the analog message waiting line card at the MDF using a wiring plan similar to that used for trunk cards. A typical connection example is shown in Figure 111 on [page 560](#) and Table 112 on [page 563](#) shows the I/O pin designations at the backplane connector. This connector is arranged as an 80-row by 2-column array of pins. Normally, these pin positions are cabled to 50-pin connectors at the I/O panel in the rear of each module for connection with 25-pair cables to the cross-connect terminal.

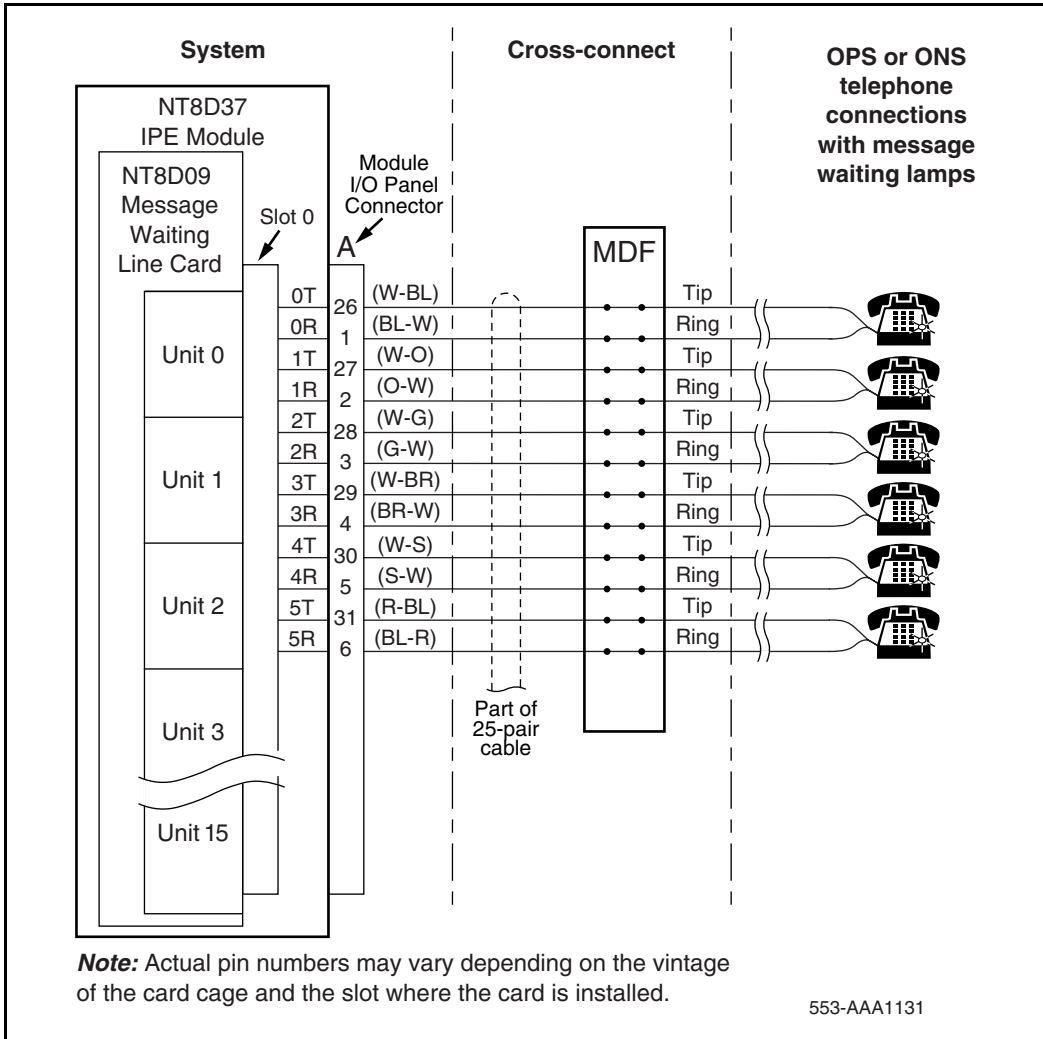
The information in Table 182 on [page 559](#) is provided as a reference and diagnostic aid at the backplane, since the cabling arrangement may vary at the I/O panel. See *Communication Server 1000M and Meridian 1: Large System*

*Installation and Configuration (553-3021-210)* for cable pinout information at the I/O panel.

**Table 182**  
**Analog message waiting line card – backplane pinouts**

<b>Backplane pinout*</b>	<b>Lead designations</b>	<b>Backplane pinout*</b>	<b>Lead designations</b>
12A	Line 0, Ring	12B	Line 0, Tip
13A	Line 1, Ring	13B	Line 1, Tip
14A	Line 2, Ring	14B	Line 2, Tip
15A	Line 3, Ring	15B	Line 3, Tip
16A	Line 4, Ring	16B	Line 4, Tip
17A	Line 5, Ring	17B	Line 5, Tip
18A	Line 6, Ring	18B	Line 6, Tip
19A	Line 7, Ring	18B	Line 7, Tip
62A	Line 8, Ring	62B	Line 8, Tip
63A	Line 9, Ring	63B	Line 9, Tip
64A	Line 10, Ring	64B	Line 10, Tip
65A	Line 11, Ring	65B	Line 11, Tip
66A	Line 12, Ring	66B	Line 12, Tip
67A	Line 13, Ring	67B	Line 13, Tip
68A	Line 14, Ring	68B	Line 14, Tip
69A	Line 15, Ring	69B	Line 15, Tip
* These pinouts apply to both NT8D37 and NT8D11 backplanes.			

**Figure 111**  
**Analog message waiting line card – typical cross connection example**





## Configuration

This section outlines the procedures for configuring the switches and jumpers on the NT8D09 Analog Message Waiting Line card and configuring the system software to properly recognize the card. Figure 112 on [page 563](#) shows where the switches and jumper blocks are located on this board.

### Jumper and switch settings

The NT8D09 Analog Message Waiting Line card has no user-configurable jumpers or switches. The card derives its address from its position in the backplane and reports that information back to the CPU through the LAN Link interface.

### Software service changes

Individual line interface units on the NT8D09 Analog Message Waiting Line card are configured using the Analog (500/2500-type) Telephone Administration program LD 10.

The message waiting feature is enabled by entering data into the customer data block using LD 15. See *Software Input/Output: Administration* (553-3001-311) for LD 10 and LD 15 service change instructions.

Analog message waiting line cards with a vintage later than NT8D09AK provide a fixed +2 dB transmission profile change in the gain of the D/A convertor. See Table 183 on [page 562](#).

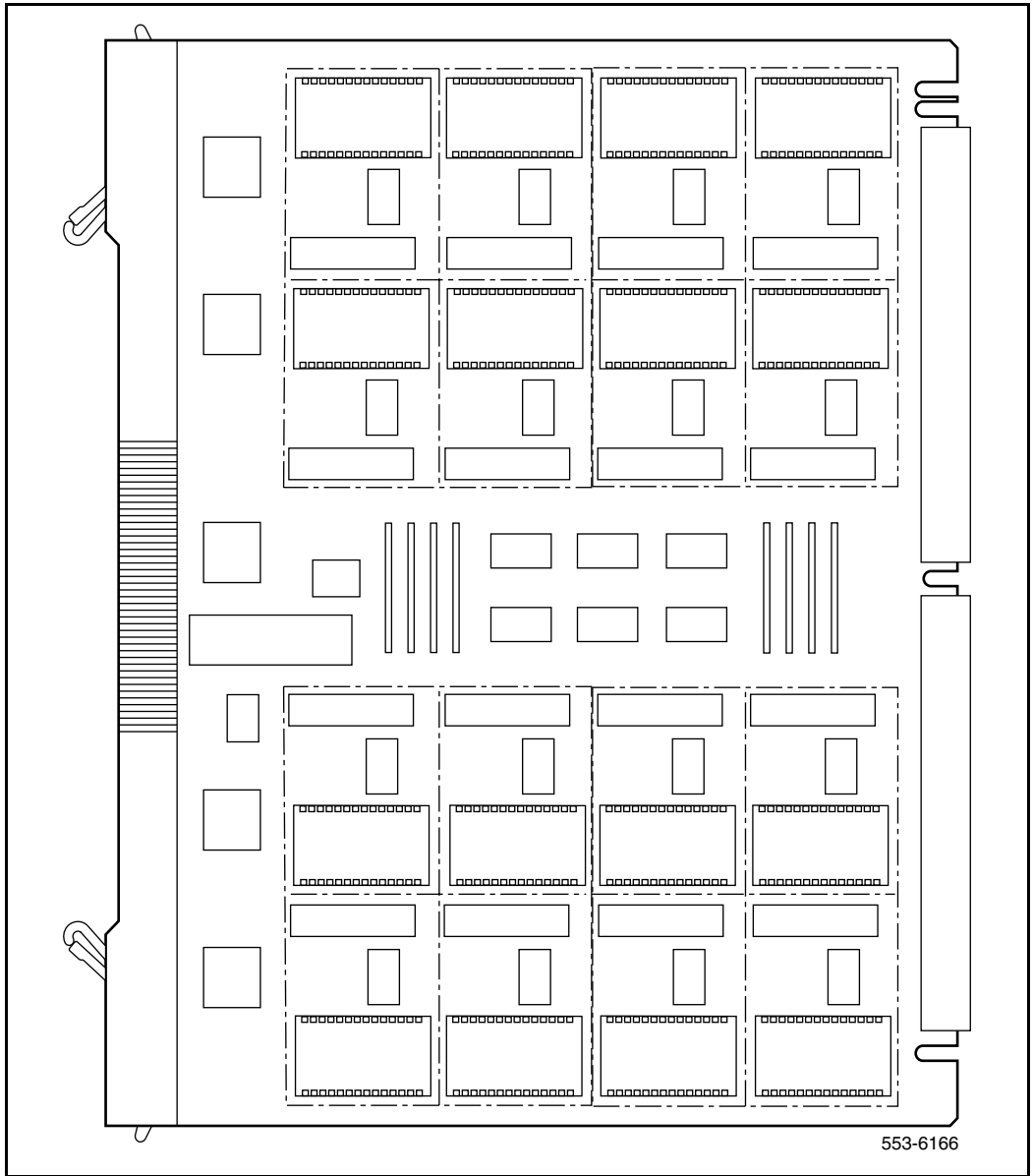
This transmission profile change is used for control of end-to-end connection loss. Control of such loss is a major element in controlling transmission parameters such as received volume, echo, noise, and crosstalk. The loss plan for the analog message waiting line card determines port-to-port loss between an analog line card unit (port) and other IPE ports. LD 97 is used to configure

the system for port-to-port loss. See *Software Input/Output: Administration* (553-3001-311) for LD 97 service change instructions.

**Table 183**  
**Transmission Profile Changes**

Vintage	A/D convertor gain	D/A convertor gain
Previous to AK	-3.5 dB	-2.5 dB
AK and later	-3.5 dB	-0.5 dB

**Figure 112**  
**Analog message waiting line card – jumper block and switch locations**





---

# NT8D14 Universal Trunk card

---

## Contents

This section contains information on the following topics:

Introduction . . . . .	565
Physical description . . . . .	567
Functional description . . . . .	570
Operation . . . . .	573
Electrical specifications . . . . .	609
Connector pin assignments . . . . .	614
Configuration . . . . .	615
Applications . . . . .	624

## Introduction

Nortel is pleased to introduce the NT8D14CA Universal Trunk (XUT) card as a replacement for the NT8D14BB card. The NT8D14CA has been modified to add a longer loop capability for CAMA trunk applications.

The NT8D14CA comes equipped with a set of 2 jumpers for each hybrid that should be set to the longer loop length (LL) when the trunk is used in a CAMA application. The jumpers are numbered P35 to P50 and are set to the shorter loop length (SL) position when it comes from the factory. For each hybrid, both jumpers should be changed to the LL position only if used as a CAMA trunk. Otherwise the jumpers should be left to the SL position.

The NT8D14 Universal Trunk card interfaces eight analog trunk lines to the system. Each trunk interface is independently configured by software control using the Trunk Administration program LD 14.

You can install this card in any IPE slot.

*Note:* Each MG 1000S can contain up to four analog trunk cards. Each MG 1000S Expansion can contain up to four analog trunk cards.

The NT8D14 Universal Trunk card supports the following trunk types:

- Centralized Automatic Message Accounting (CAMA) trunks
- Central Office (CO), Foreign Exchange (FEX), and Wide Area Telephone Service (WATS) trunks
- Direct Inward Dial (DID) trunks
- Tie trunks: two-way Loop Dial Repeating (LDR) and two-way loop Outgoing Automatic Incoming Dial (OAID)
- Recorded Announcement (RAN) trunks
- Paging trunks

The NT8D14 Universal Trunk card also supports Music, Automatic Wake Up, and Direct Inward System Access (DISA) features.

Table 184 lists the signaling and trunk types supported by the NT8D14 Universal Trunk card.

**Table 184**  
**Trunk and signaling matrix**

Signaling type	Trunk types					
	CO/FX/ WATS	DID	Tie	RAN	Paging	CAMA
Loop start	Yes	No (see note)	No	N/A	N/A	Yes
Ground start	Yes	No	No	N/A	N/A	No
Loop DR	No	Yes	Yes	N/A	N/A	No
Loop OAID	No	No	Yes	N/A	N/A	No
Continuous operation mode	No	No	No	Yes	N/A	No
Start modes (pulse and level)	No	No	No	Yes	N/A	No
<b>Note:</b> For incoming and outgoing service, DID trunks must be programmed as loop dial repeating.						

## Physical description

The trunk and common multiplexing circuitry is mounted on a 31.75 cm by 25.40 cm (12.5 in. by 10 in.) printed circuit board.

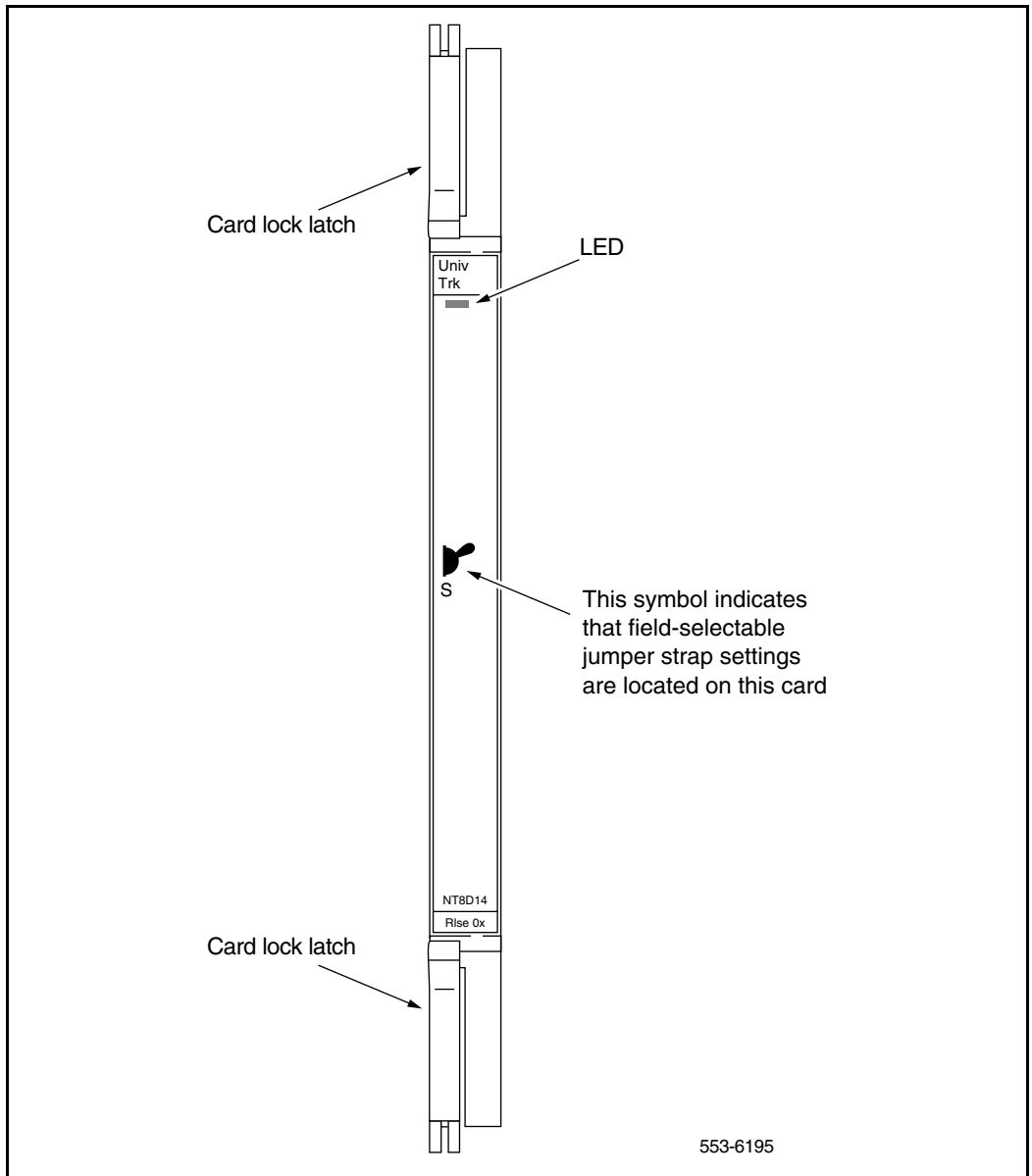
The NT8D14 Universal Trunk card connects to the backplane through a 160-pin connector shroud. The backplane is cabled to the I/O panel, which is cabled to the Main Distribution Frame (MDF) by 25-pair cables. External equipment, such as recorded announcement machines, paging equipment, and Central Office facilities, connect to the card at the MDF.

See the *Communication Server 1000S: Installation and Configuration* (553-3031-210) for termination and cross-connect information.

The faceplate of the card is equipped with a red Light Emitting Diode (LED). See Figure 113 on [page 569](#). When an NT8D14 Universal Trunk card is installed, the LED remains lit for two to five seconds while the self-test runs. If the self-test is successful, the LED flashes three times and remains lit. When the card is configured and enabled in software, then the LED goes out. If the LED flashes continuously or remains weakly lit, replace the card.



Figure 113  
Universal trunk card – faceplate

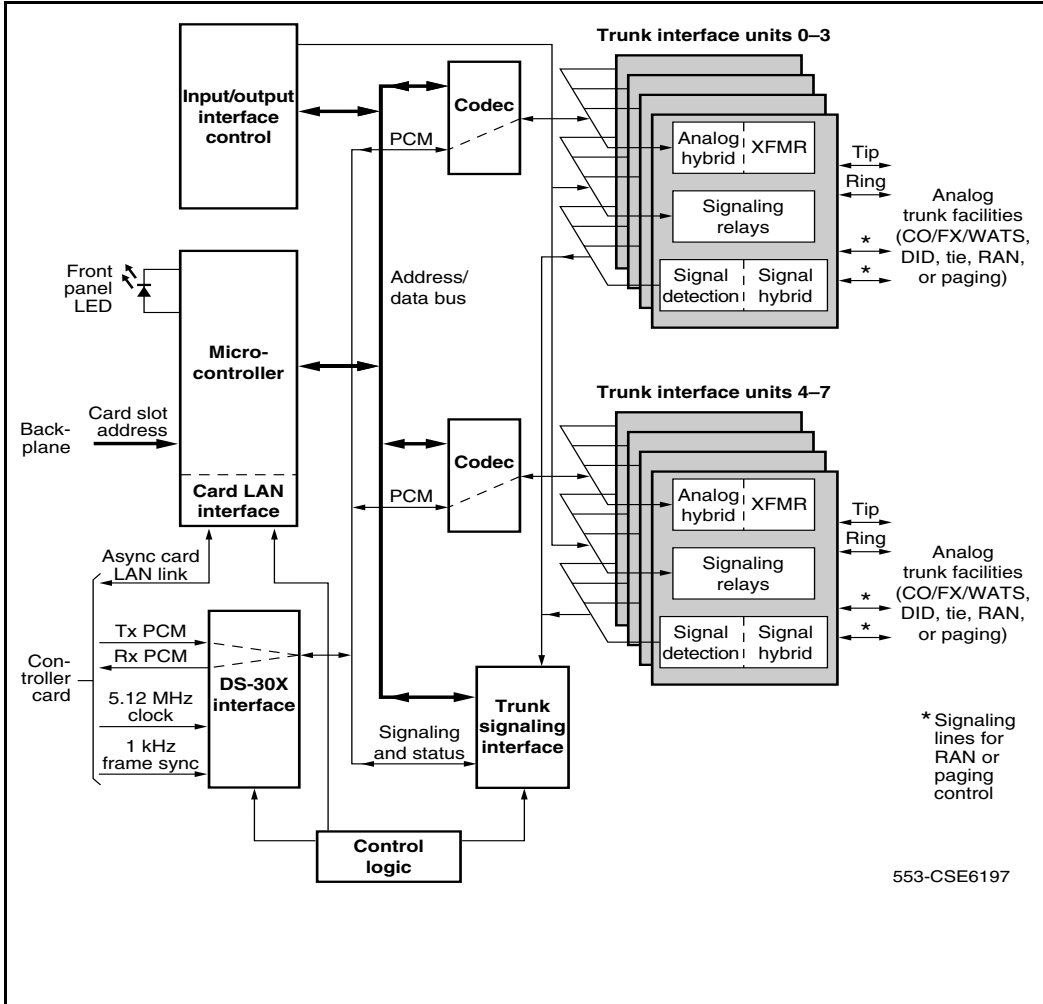


553-6195

## Functional description

Figure 114 shows a block diagram of the major functions contained on the NT8D14 Universal Trunk card. Each of these functions is described on the following pages.

**Figure 114**  
**NT8D14 Universal trunk card – block diagram**



## Card interfaces

The NT8D14 Universal Trunk card passes voice and signaling data over DS-30X loops, and maintenance data over the card LAN link. These interfaces are described in “Intelligent Peripheral Equipment” on [page 32](#).

### Trunk interface units

The NT8D14 Universal Trunk card contains eight identical and independently configurable trunk interface units (also referred to as circuits). Each unit provides impedance matching and a balanced network in a signal transformer/analog hybrid circuit.

Also provided are relays for placing outgoing call signaling onto the trunk. Signal detection circuits monitor incoming call signaling. Two codecs are provided for performing A/D and D/A conversion of trunk analog voiceband signals to digital PCM signals. Each codec supports four trunk interface units. The following features are common to all units on the card:

- trunk type configurable on a per unit basis
- terminating impedance (600 or 900 ohms) selectable on a per-unit basis (minimum vintage BA)
- balance impedance (600 or 900 ohms or complex impedance network) selectable on a per-unit basis (minimum vintage BA)
- control signals provided for RAN and paging equipment
- loopback of PCM signals received from trunk facility over DS-30X network loop for diagnostic purposes
- switchable pads for transmission loss control

## Card control functions

Control functions are provided by a microcontroller, a card LAN interface, and signaling and control circuits on the NT8D14 Universal Trunk card.

### Microcontroller

The NT8D14 Universal Trunk card contains a microcontroller that controls the internal operation of the card and the serial card LAN link to the controller card. The microcontroller controls the following:

- reporting to the CE CPU through the card LAN link:
  - card identification (card type, vintage, and serial number)
  - firmware version
  - self-test status
  - programmed configuration status
- receipt and implementation of card configuration through the card LAN link:
  - programming of the codecs
  - enabling/disabling of individual units or entire card
  - programming of input/output interface control circuits for administration of trunk interface unit operation
  - maintenance diagnostics
  - transmission pad settings

### Card LAN interface

Maintenance data is exchanged with the common equipment CPU over a dedicated asynchronous serial network called the Card LAN link.

### Signaling and control

The signaling and control portion of the Universal Trunk card works with the CPU to operate the card hardware. The card receives messages from the CPU over a signaling channel in the DS-30X loop and returns status information to the CPU over the same channel. The signaling and control portion of the card

provides the means for analog loop terminations to establish, supervise, and take down call connections.

## Signaling interface

All trunk signaling messages are three bytes long. The messages are transmitted in channel zero of the DS-30X in A10 format.

Configuration information for the Universal Trunk card is downloaded from the CPU at power-up or by command from maintenance programs. Eleven configuration messages are sent. Three messages are sent to the card to configure the make/break ratio and A-Law or  $\mu$ -Law operation. One message is sent to each unit to configure the trunk characteristics.

## Operation

Administrators can assign optional applications, features, and signaling arrangements for each unit on the NT8D14 Universal Trunk card through the Trunk Administration LD 14 and Trunk Route Administration LD 16 programs or jumper strap settings on the card.

### Loop start operation

Loop start operation is configured in software and implemented in the card through software download messages. When the card is idle, it provides a high impedance toward the CO for isolation and ac (ringing) detection.

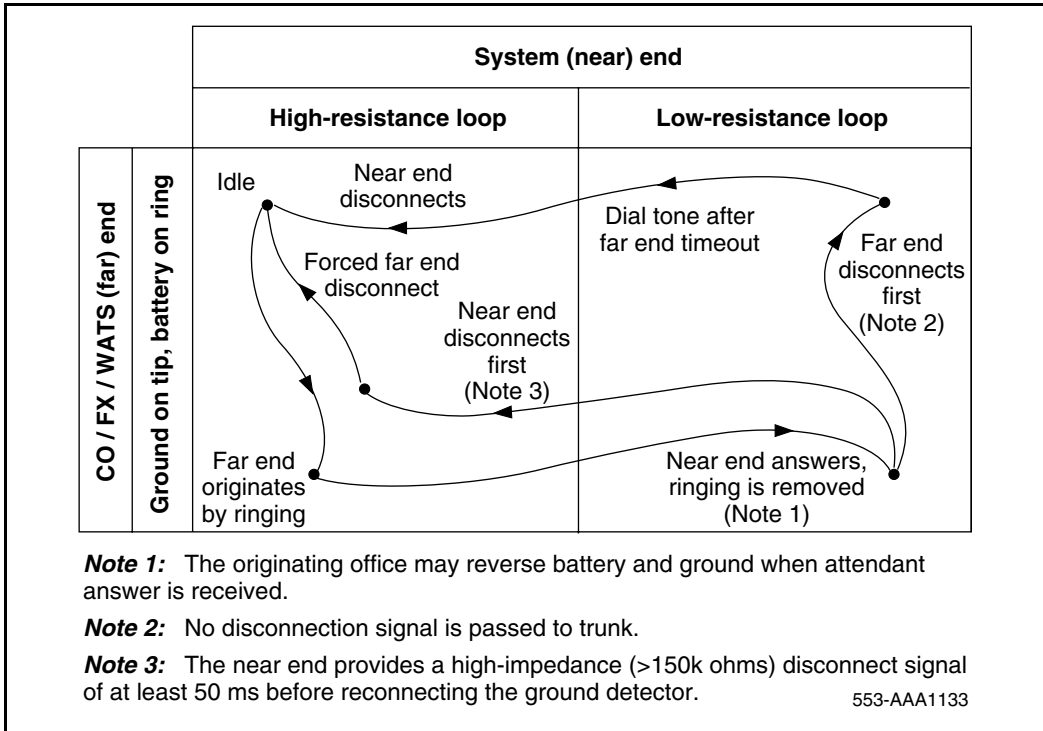
#### Incoming calls

The alerting signal into the System is 20 Hz (nominal) ringing sent by the CO. When an incoming call is answered, ringing is tripped when the System places a low-resistance dc loop across the tip and ring leads toward the CO. See Figure 115 and Figure 116 on [page 575](#).

#### Outgoing calls

For outgoing calls, the software sends an outgoing seizure message to place a low-resistance loop across the tip and ring leads toward the CO. See Figure 117 on [page 576](#) and Figure 118 on [page 577](#). When the CO detects the low-resistance loop, it prepares to receive digits. When the CO is ready to

**Figure 115**  
**Loop start call states – incoming call from CO/FX/WATS**



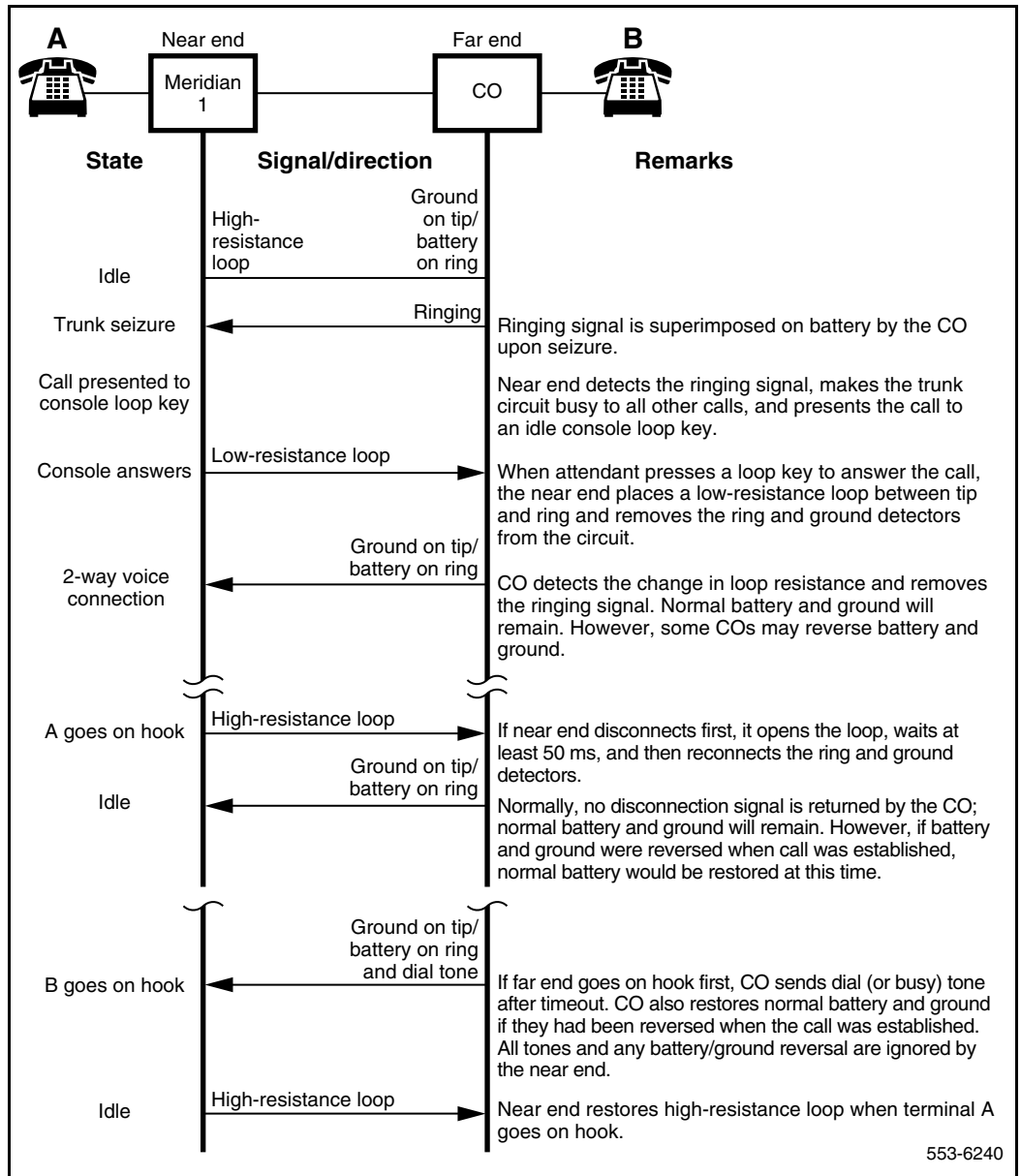
receive digits, it returns a dial tone. Outward address signaling is then applied from the system in the form of loop (interrupting) dial pulses or DTMF tones.

***Polarity-sensitive/-insensitive packs feature***

The CS 1000 Release 4.5 software provides the polarity-sensitive/polarity-insensitive (PSP and PIP) packs feature for the accurate recording of outgoing call duration for loop start and ground start operation.

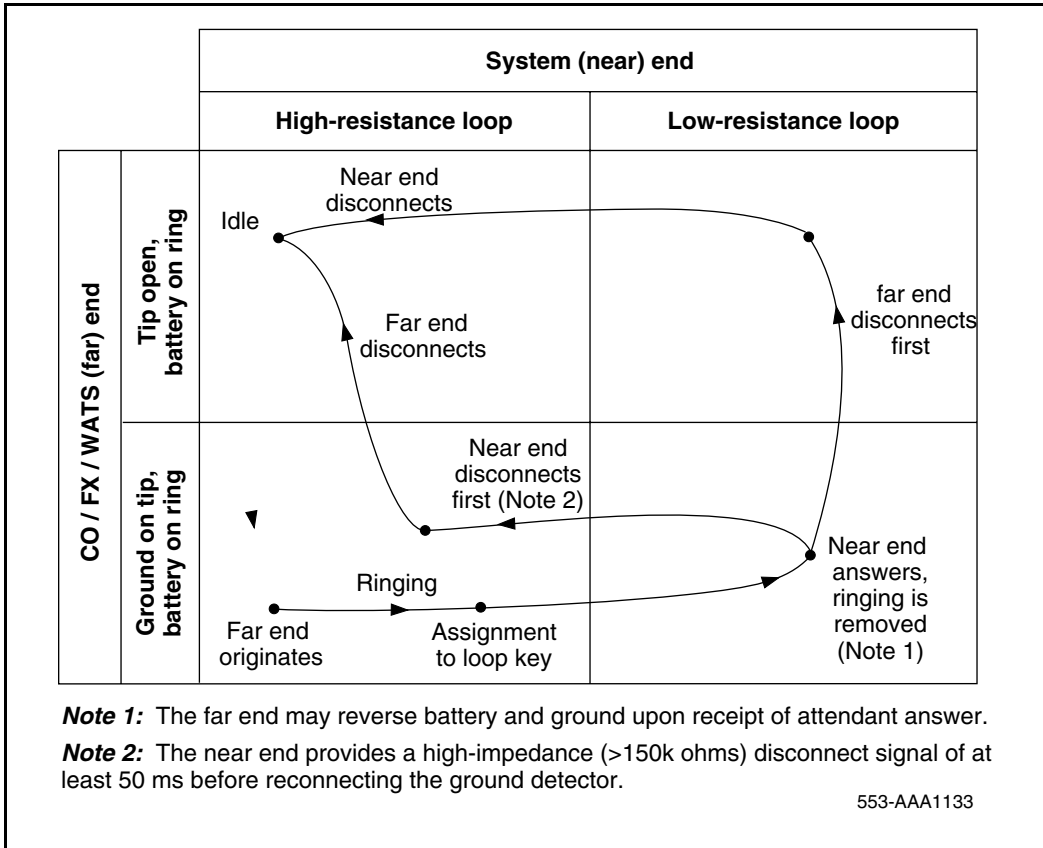
On trunks equipped with far-end answer supervision, the PSP class of service is enabled in software and causes call-duration recording in CDR records to begin only upon receipt of answer supervision from the far-end.

**Figure 116**  
**Loop start call connection sequence – incoming call from CO/FX/WATS**



553-6240

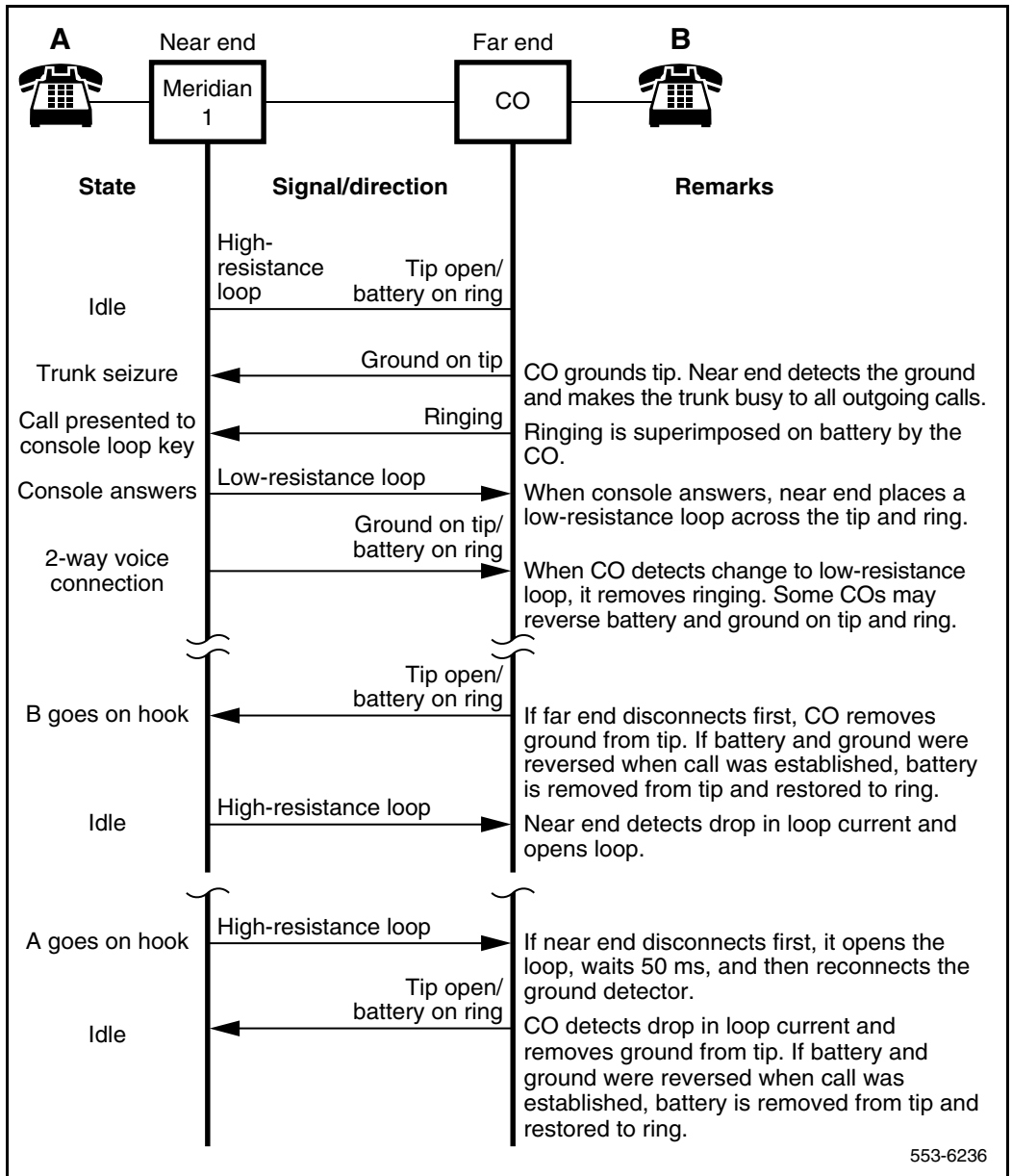
Figure 117  
Ground start call states – incoming call from CO/FX/WATS



For trunks not equipped with answer supervision, the PIP class of service is enabled and call-duration recording begins immediately upon near-end trunk seizure. The PSP and PIP classes of service are enabled in the Trunk Administration program LD 14.



**Figure 118**  
**Ground start call connection sequence – incoming call from CO/FX/WATS**



553-6236

## Ground start operation

Ground start operation is configured in software and implemented through software download messages. In the idle state, the tip conductor from the CO is open and a high-resistance negative battery is present on the ring lead.

### Incoming calls

In an incoming call, after ground is detected on the tip, the universal trunk card scans for a ringing detection signal before presenting the call to an attendant and tripping the ringing. When the attendant answers, a low resistance is placed across the tip and ring conductors, which trips CO ringing and establishes a speech path. See Figure 119 on [page 579](#) and Figure 120 on [page 580](#).

### *Reverse-wiring compensation*

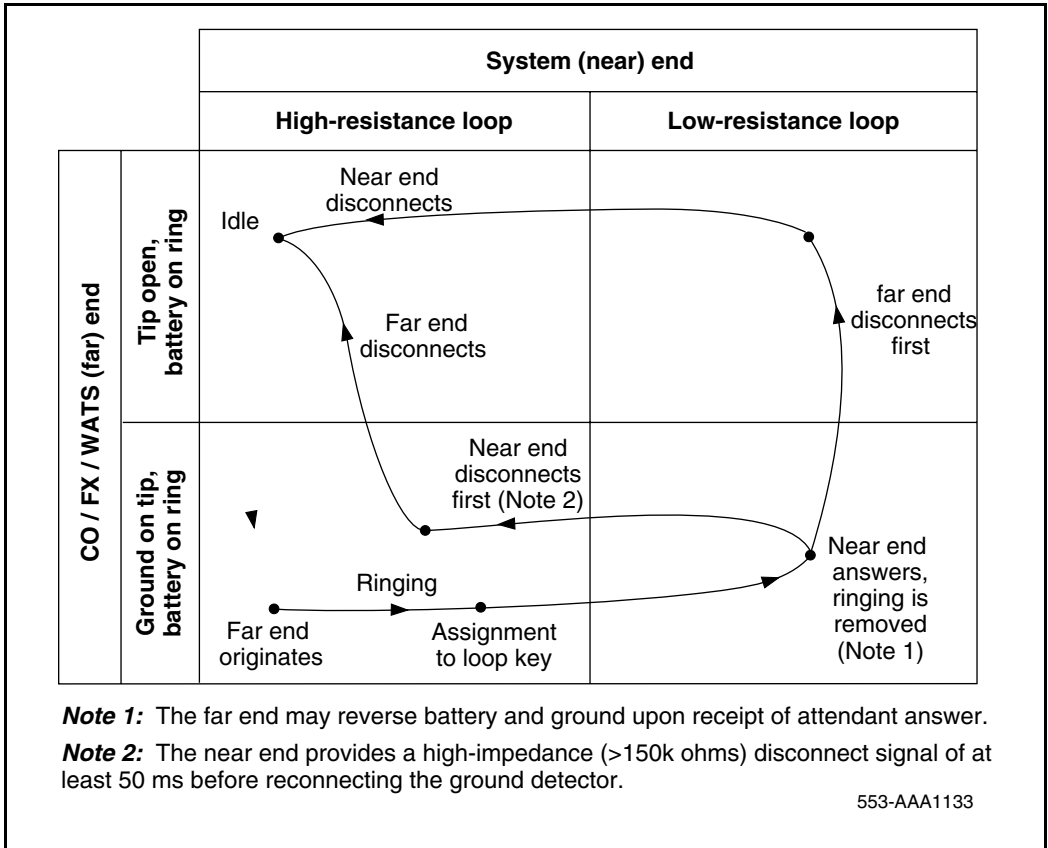
The CS 1000 Release 4.5 software includes a feature for detecting reverse wiring (connection of the near-end tip and ring leads to the far-end ring and tip leads) on ground start trunks with far-end answer supervision.

Ordinarily, an incoming call on a reverse-wired trunk without reverse-wiring compensation presents ringing on the tip lead rather than on the ring lead. Since the software expects to see a ground on the tip lead, it interprets the end of the first ringing signal as a switchhook flash. But since the interval between ringing signals exceeds the switchhook flash time of 512 milliseconds, the software assumes a far-end disconnect. This causes the call to be presented to a console loop key and then immediately removed.

The reverse-wiring compensation feature operates as follows. If an apparent disconnect takes place immediately after the first ringing signal, the software time stamps the event and temporarily remove the call from the console loop key.

If another such ringing/disconnect event occurs during the No Ringing Detector (NRD) time, the trunk is considered “possibly reverse-wired” and a threshold counter starts. Calls on trunks identified as possibly reverse-wired are presented to the attendant during the initial ring, removed, and then continuously presented after the second ring. If a call on a possibly reverse-wired trunk is abandoned before the attendant answers, it is disconnected after the NRD timer expires.

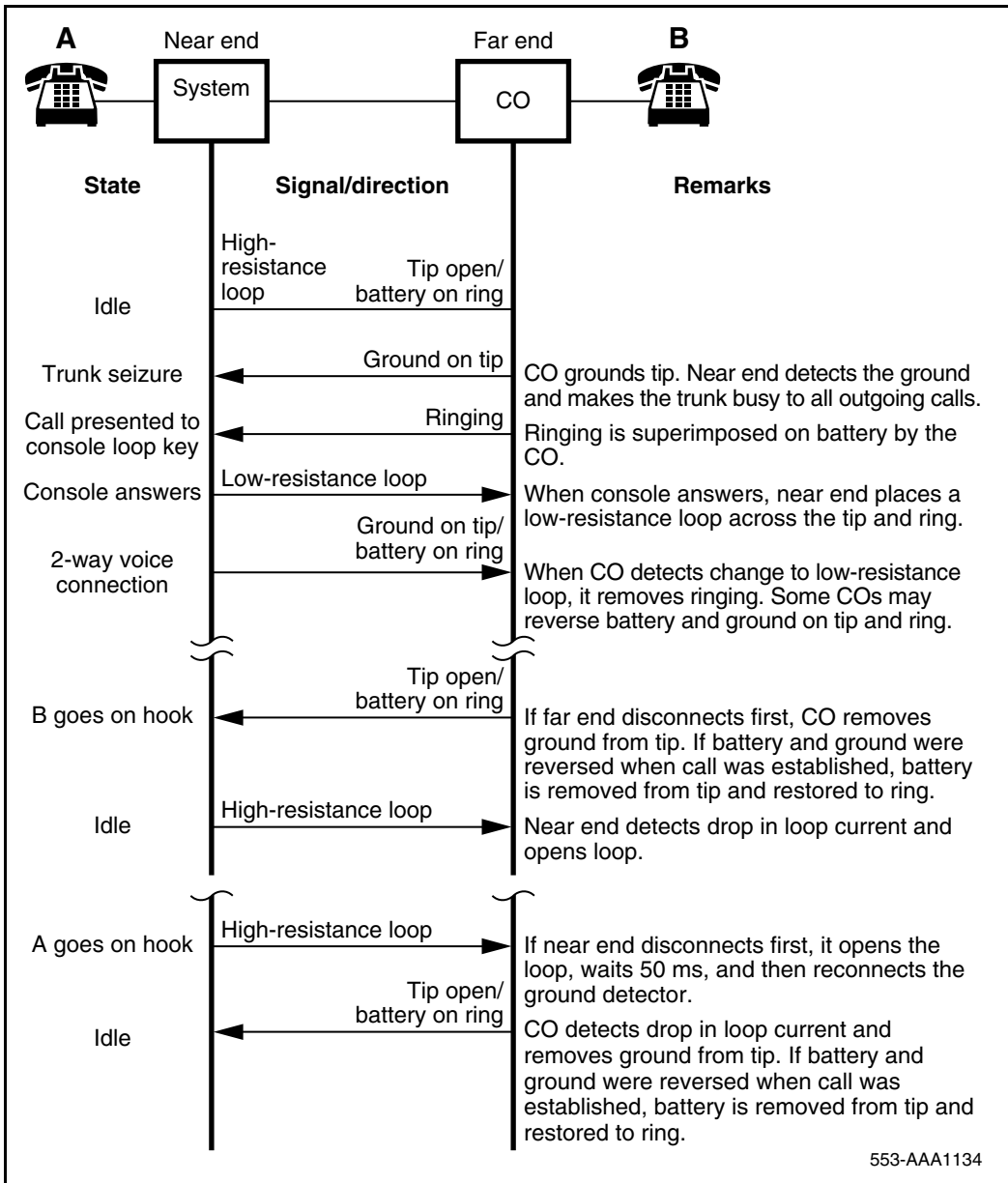
**Figure 119**  
**Ground start call states – incoming call from CO/FX/WATS**



A trunk identified as possibly reverse-wired is switched by the software to loop start processing after the second ring. This switching takes place on a call-by-call basis. Thus, if a previously correctly wired trunk becomes reverse-wired, the next incoming call is marked as possibly reverse-wired and the threshold count begins.

If the threshold count exceeds its limit, an error message is printed and the trunk is registered as “*positively* reverse wired.” Once identified as positively reverse wired, the call is presented continuously from the first ring. When a

**Figure 120**  
**Ground start call connection sequence – incoming call from CO/FX/WATS**



553-AAA1134

reverse-wired trunk becomes correctly wired, the first subsequent call clears the threshold counter and normal ground start processing is implemented.

**Note 1:** The far-end can reverse battery and ground upon receipt of attendant answer.

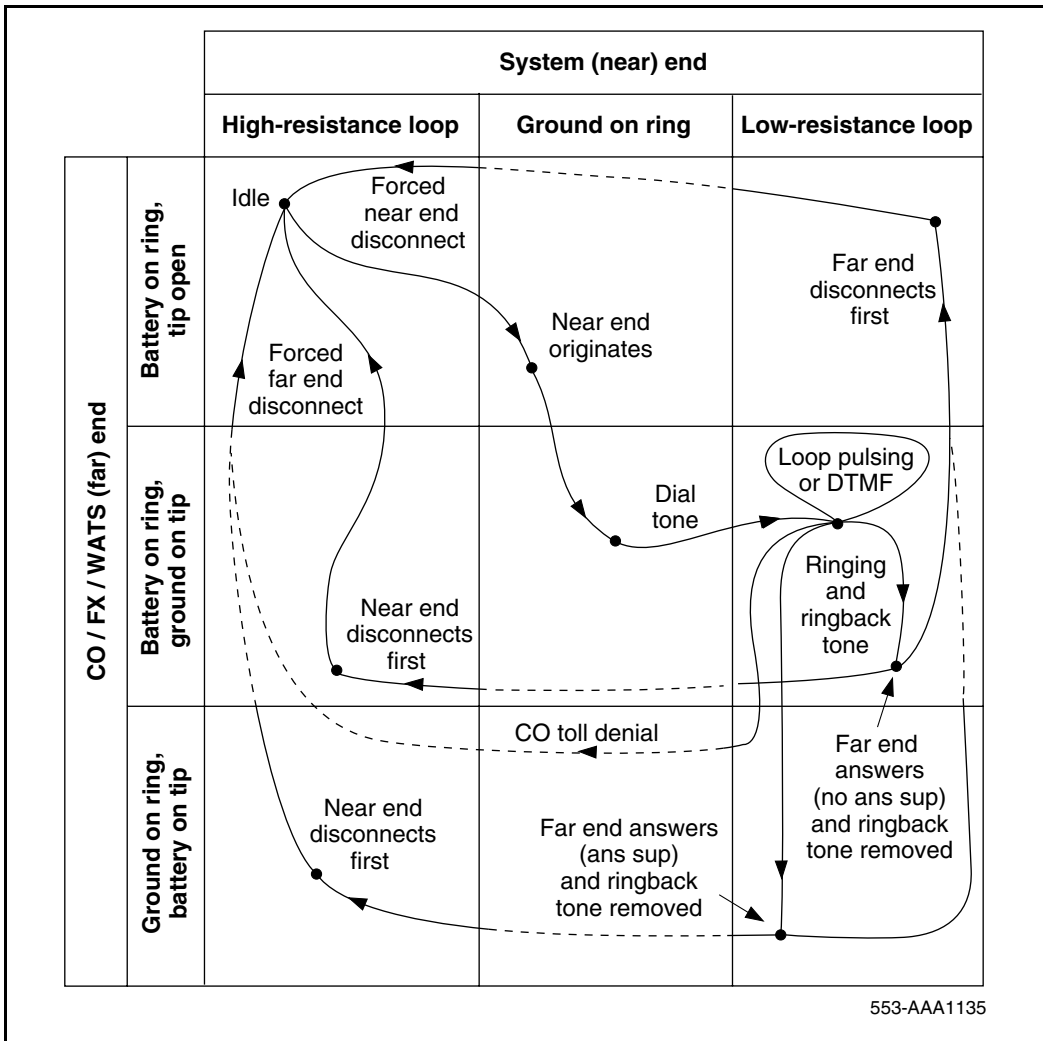
**Note 2:** The near-end provides a high-impedance (>150k ohms) disconnect signal of at least 50 ms before reconnecting the ground detector.

### **Outgoing calls**

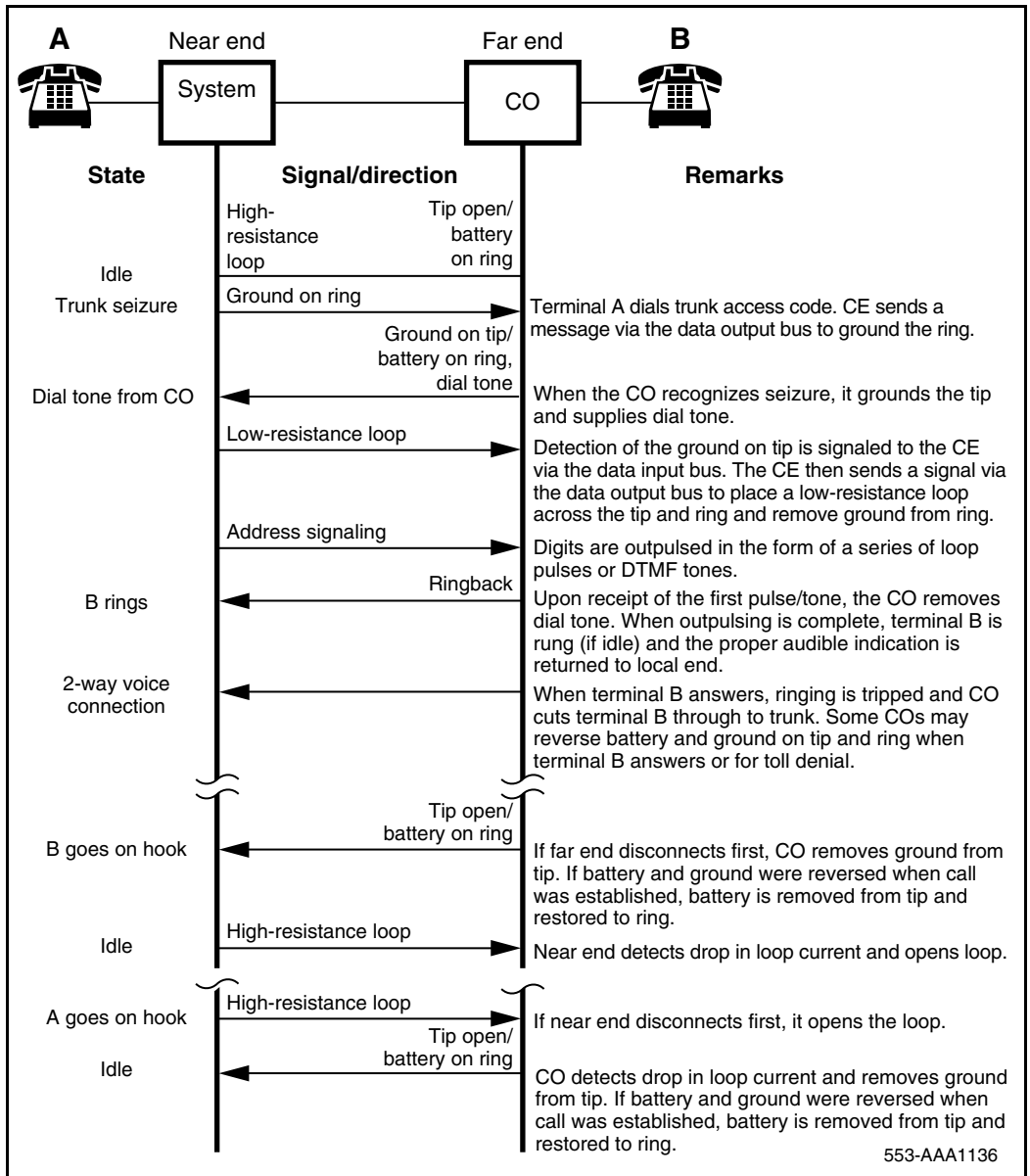
For outgoing calls, the trunk provides a ground to the ring lead. The CO responds by grounding the tip and returning dial tone. After the tip ground is detected by the card, a low-resistance path is placed between the tip and ring leads and the ground is removed from the ring. Addressing is then applied from the system in the form of loop (interrupting) dial pulses or DTMF tones. See Figure 121 on [page 582](#) and Figure 122 on [page 583](#).

The Polarity-Sensitive/Polarity-Insensitive Packs (PSP and PIP) feature must be set to provide for proper outgoing call-duration recording with ground start operation. Refer to the description of loop start operation in this section for a more complete discussion of PSP and PIP.

Figure 121  
Ground start call states – outgoing call to CO/FX/WATS



**Figure 122**  
**Ground start call connection sequence – outgoing call to CO/FX/WATS**



## Direct inward dial operation

### Incoming calls

An incoming call from the CO places a low-resistance loop across the tip and ring leads. See Figure 123 on [page 585](#) and Figure 124 on [page 586](#).

Dial pulses or DTMF tones are then presented from the CO. When the called party answers, the universal trunk card reverses battery and ground on the tip and ring leads to the CO. The trunk is arranged for first party release. The CO releases the trunk by removing the low-resistance loop, at which time normal battery and ground are restored at the near-end. This also applies to incoming tie trunk calls from a far-end PBX.

*Note:* The near-end can be configured for immediate start, delay dial, or wink start.

## Two-way, loop dial repeating, TIE trunk operation

### Incoming calls

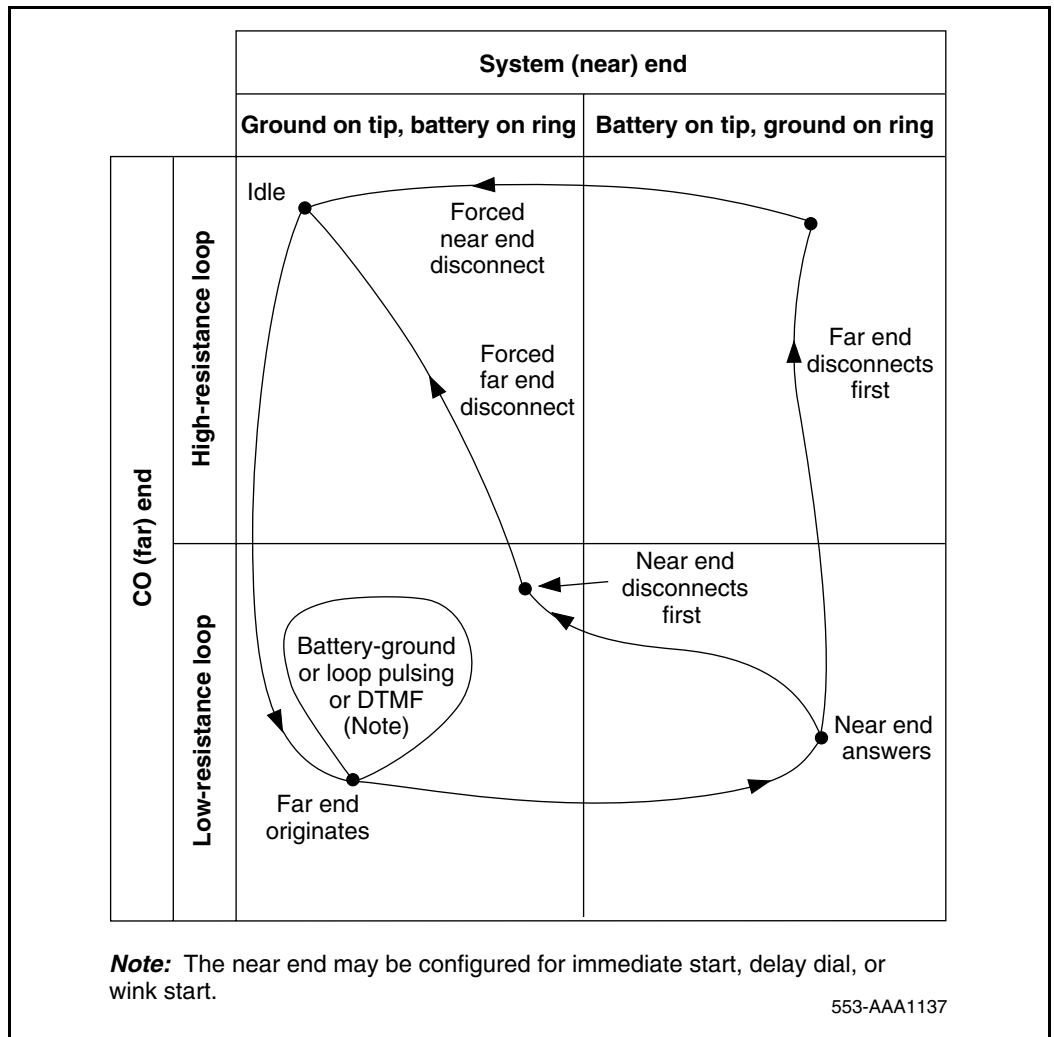
In an incoming call configuration, the far-end initiates a call by placing a low-resistance loop across the tip and ring leads. See Figure 125 on [page 587](#) and Figure 126 on [page 588](#).

This causes a current to flow through the battery feed resistors in the trunk circuit. Address signaling is then applied by the far-end in the form of DTMF tones or dial pulses. When the called party answers, an answer supervision signal is sent by the software, causing the System to reverse battery and ground on the tip and ringleads to the far-end. Far-end disconnect is initiated by opening the loop while the near-end disconnect is initiated by restoring normal battery and ground. The operation represented in Figure 125 on [page 587](#) and Figure 126 on [page 588](#) also applies to incoming DID trunk calls from a CO.

*Note:* Where no near-end answer supervision is provided, the party at the far-end hangs up after recognizing near-end call termination.



Figure 123  
 DID trunk, loop DR call states – incoming call from CO



**Figure 124**  
**DID trunk, loop DR call connection sequence – incoming call from CO**

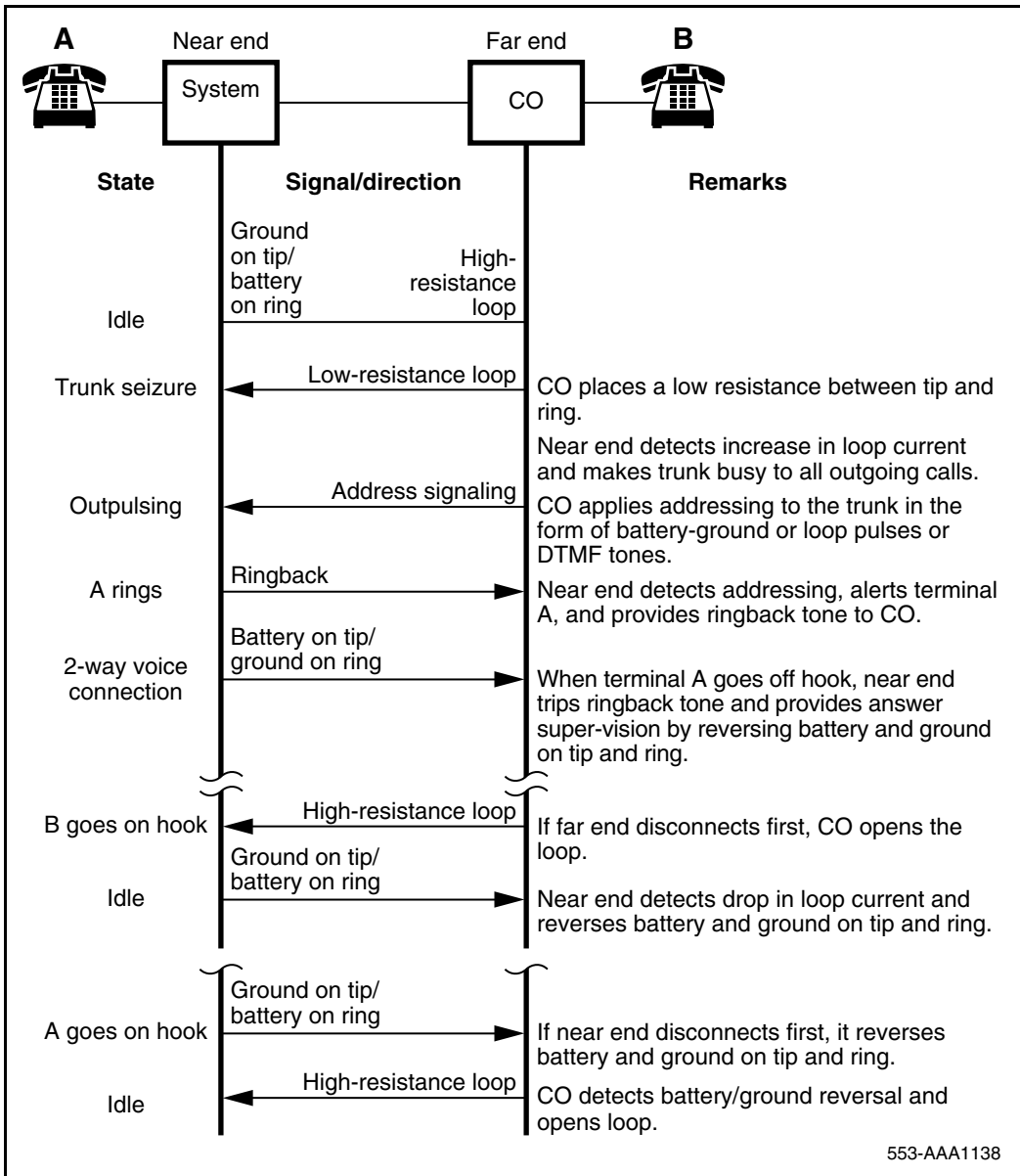
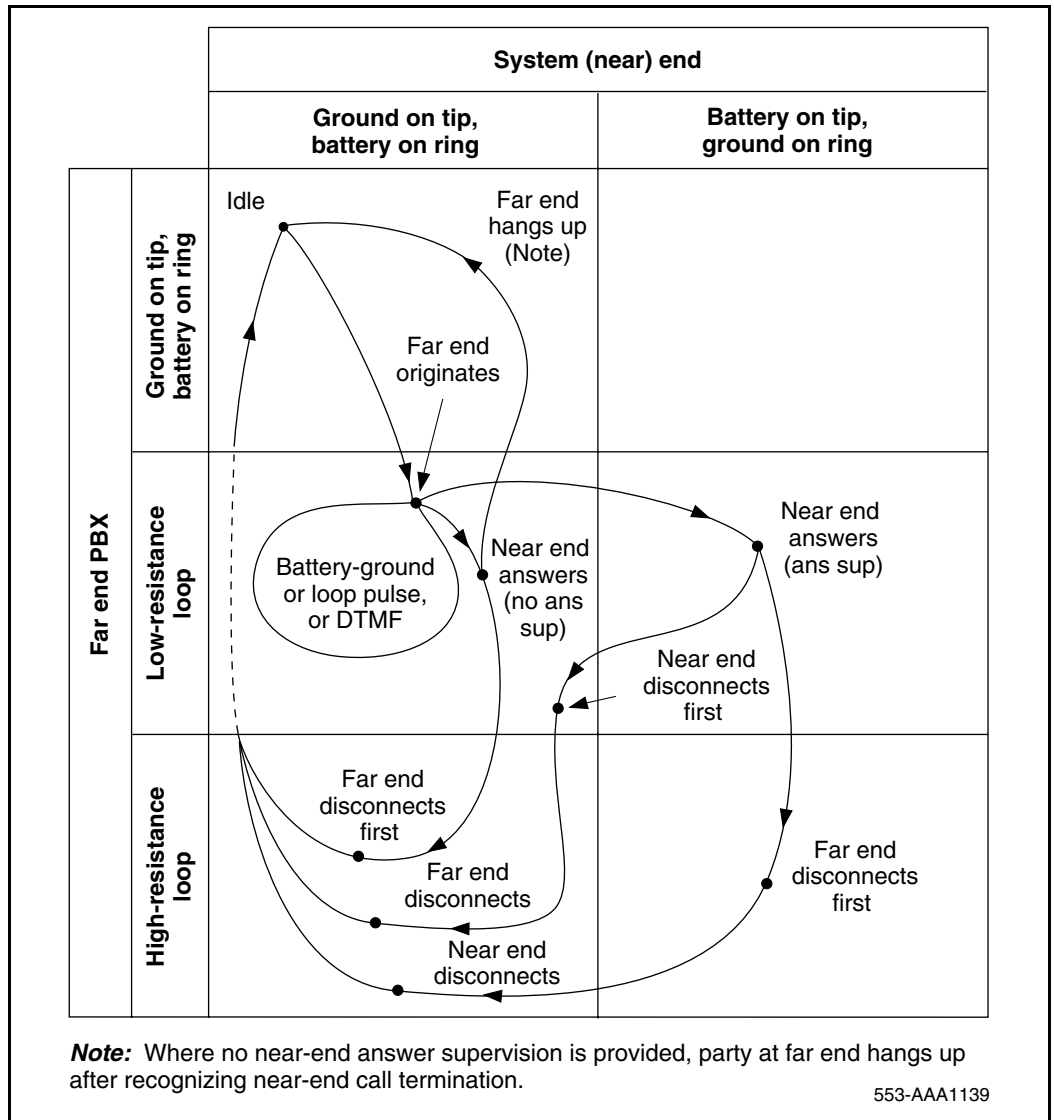
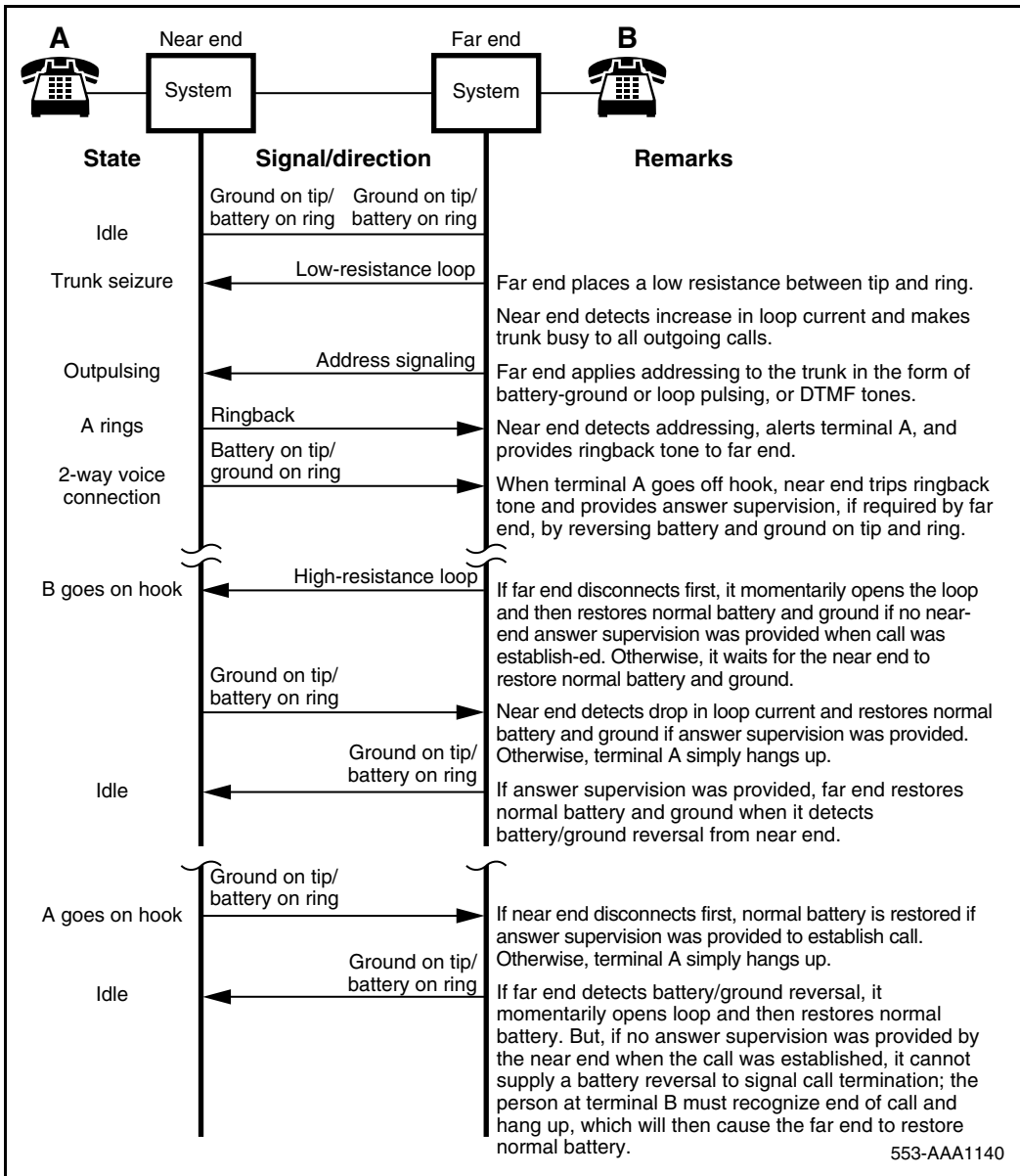


Figure 125  
Two-way, loop DR, TIE trunk call states – incoming call from far-end PBX



**Figure 126**  
**Two-way, loop DR, TIE trunk call connection sequence – incoming call from far-end PBX**



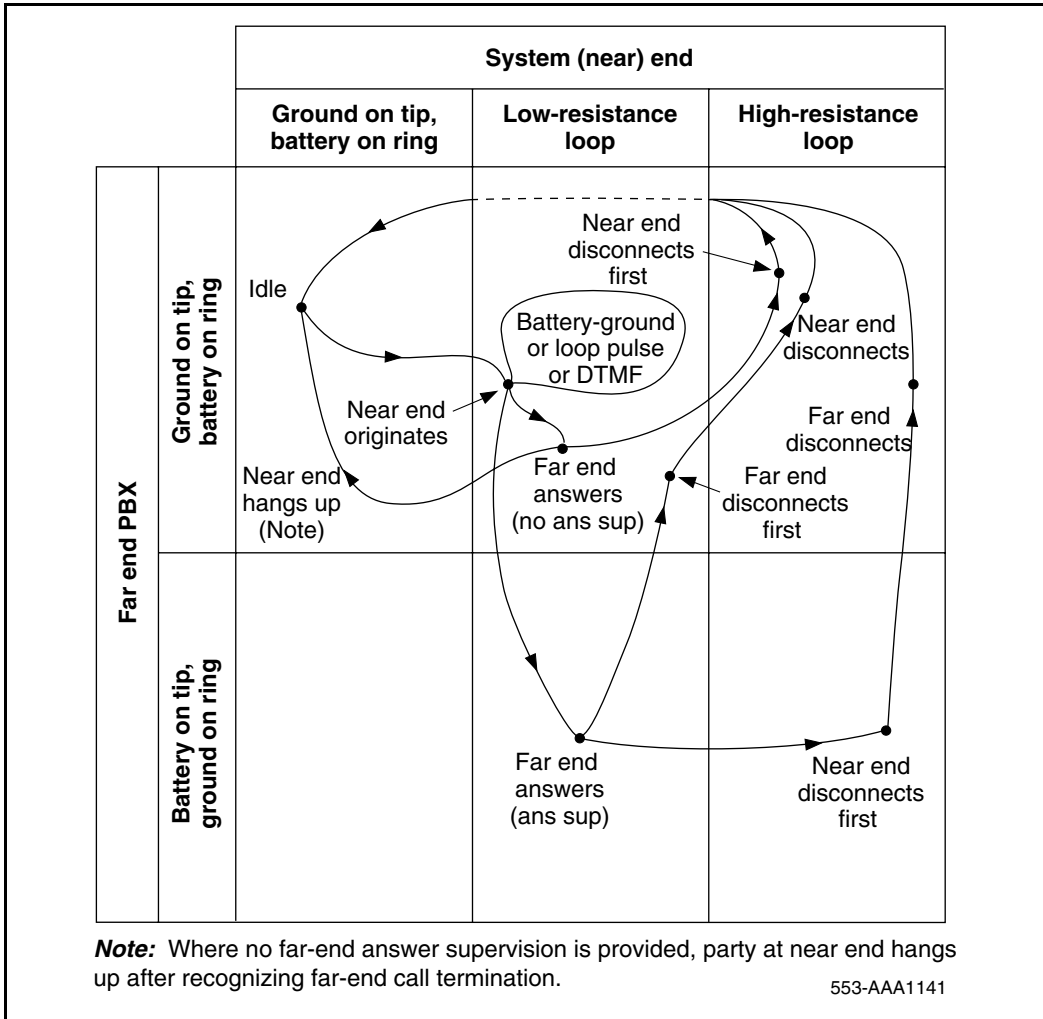
## Outgoing calls

In an outgoing call configuration, the NT8D14 Universal Trunk card is connected to an existing PBX by a tie trunk. See Figure 127 on [page 590](#) and Figure 128 on [page 591](#).

An outgoing call from the near-end seizes the trunk facility by placing a low-resistance loop across the tip and ring leads. Outward addressing is then applied from the System in the form of DTMF tones or dial pulses. If answer supervision is provided by the far-end, reverse battery and ground on the tip and ring leads are returned. The operation represented in Figure 129 on [page 592](#) and Figure 130 on [page 593](#) also applies to outgoing calls on a DID trunk.

**Note:** Where no far-end answer supervision is provided, the party at the near-end hangs up, after recognizing far-end call termination.

Figure 127  
Two-way, loop DR, TIE trunk call states – outgoing call to far-end PBX



**Figure 128**  
**Two-way, loop DR, TIE trunk call connection sequence – outgoing call to far-end PBX**

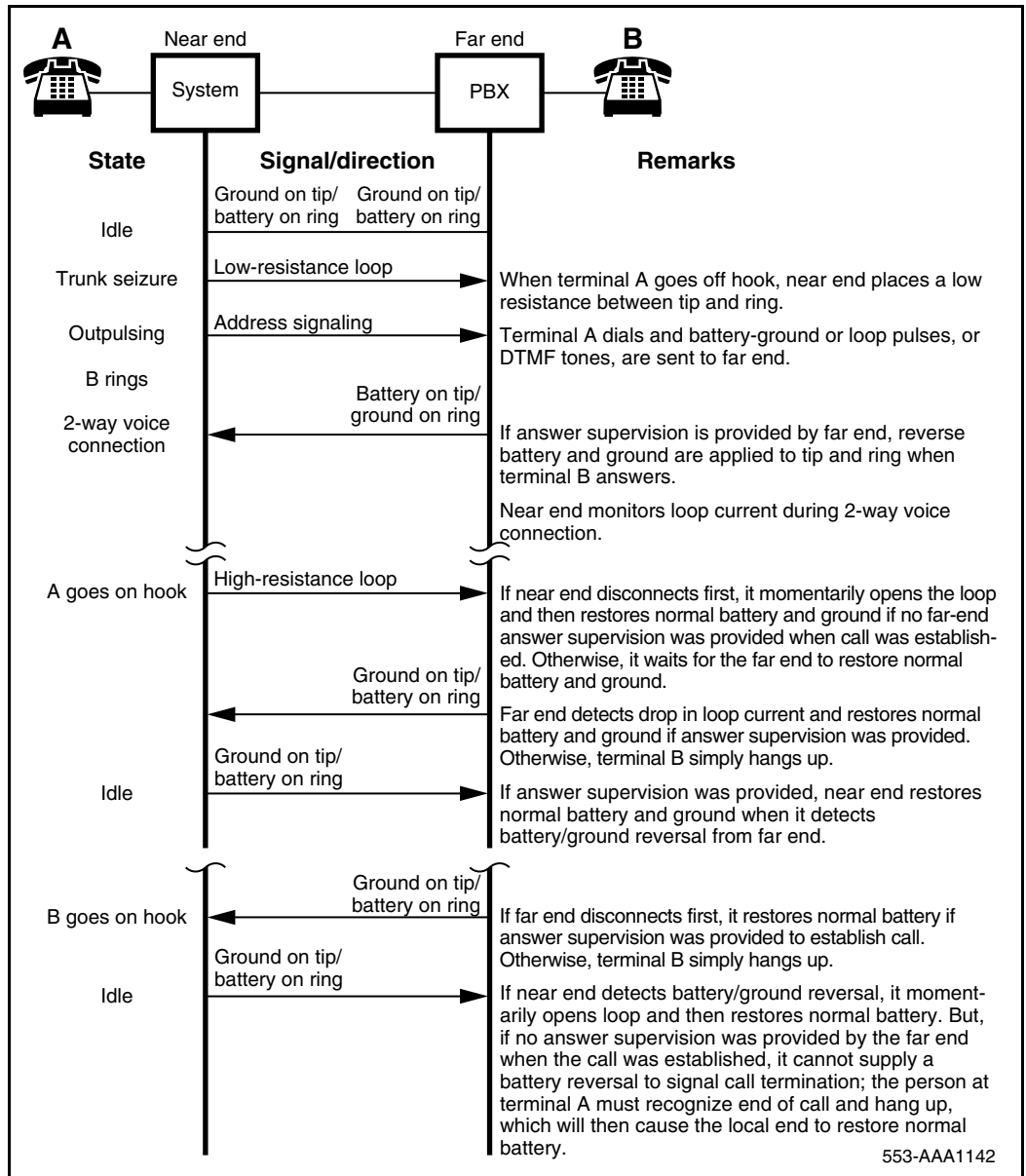
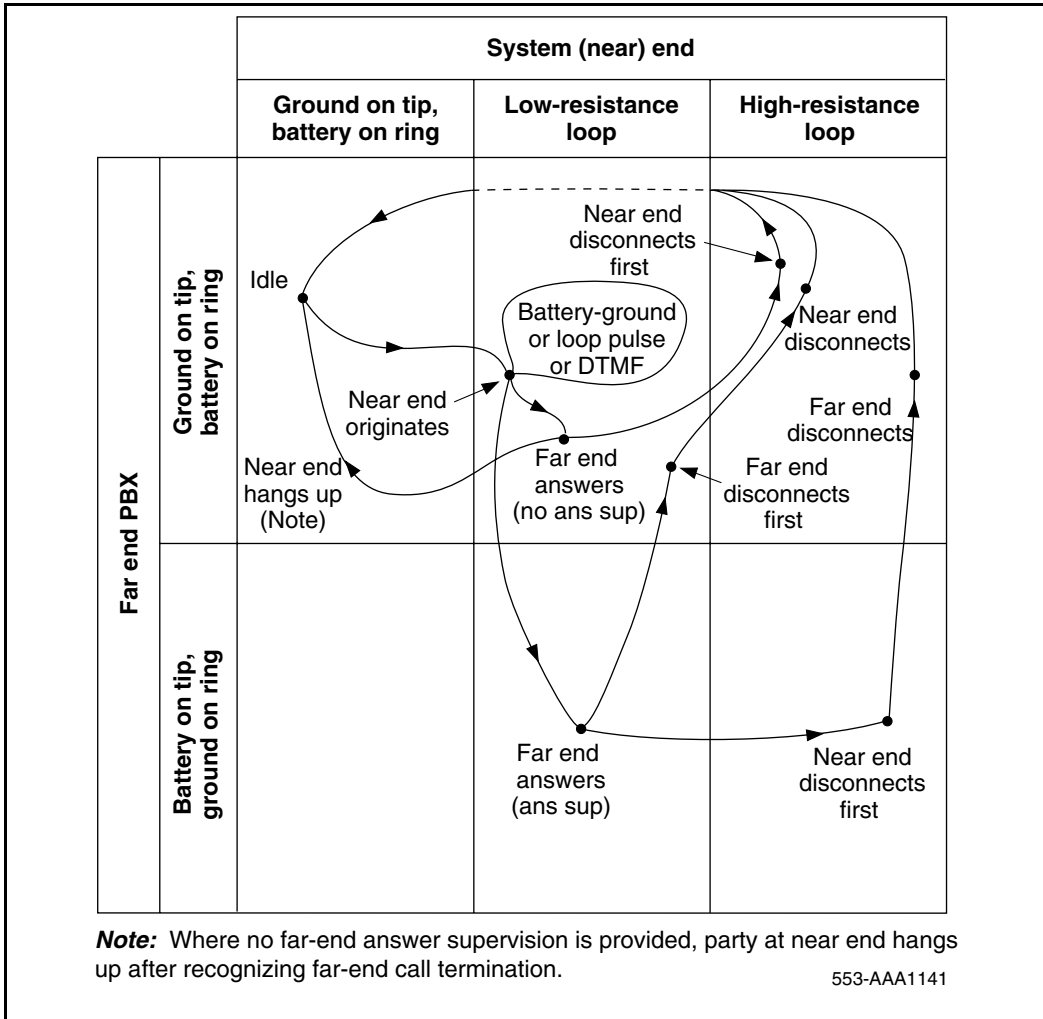
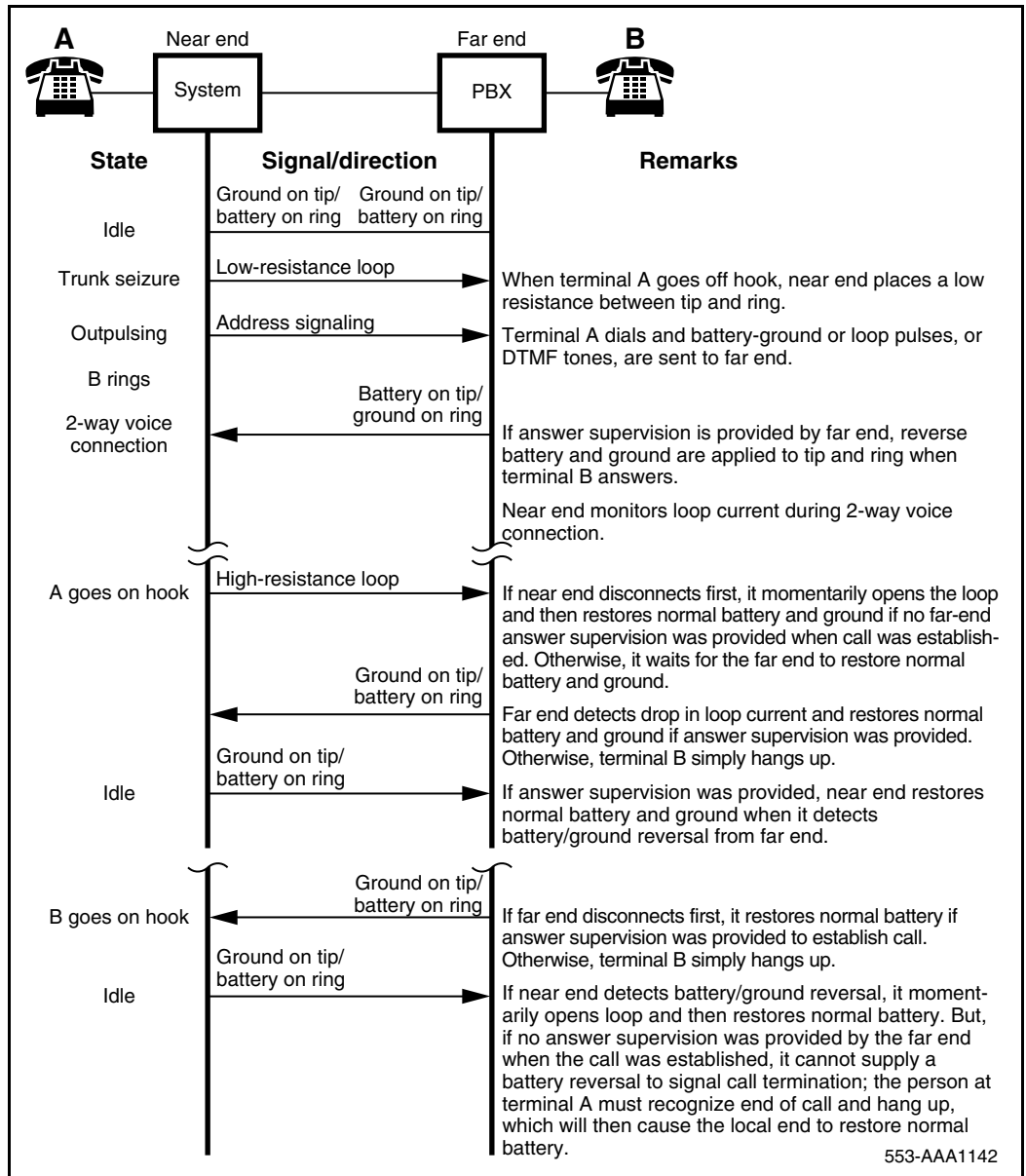


Figure 129  
Two-way, loop DR, TIE trunk call states – outgoing call to far-end PBX





**Figure 130**  
**Two-way, loop DR, TIE trunk call connection sequence – outgoing call to far-end PBX**



## Senderized operation for DID and two-way loop DR trunks

### Incoming calls

If the far-end is senderized, the near-end can operate in any mode: Immediate Start (IMM), Delay Dial (DDL) or Wink (WNK) start, as assigned at the STRI prompt in the Trunk Administration program LD 14. See Figure 131 on [page 595](#).

*Note:* If a ground start trunk, the outpulse towards office occurs after ground detection. If a loop start trunk, the outpulse towards office occurs one second later.

For immediate start, following the seizure signal, the far-end starts pulsing after the standard delay (normally 65 ms, minimum).

For delay dial or wink start modes, stop/go signaling (off hook/on hook or battery/ground reversal) is returned by the System after receipt of the seizure signal. The delay dial (stop) signal begins immediately upon seizure and ends (go signal) 384 ms later. The wink start (stop) signal begins 384 ms after seizure and ends (go signal) 256 ms later. The far-end detecting the go signal starts pulsing after the standard delay (normally 55 ms, minimum). Stop/go signaling, in addition to the signaling function, serves as an integrity check to help identify a malfunctioning trunk.

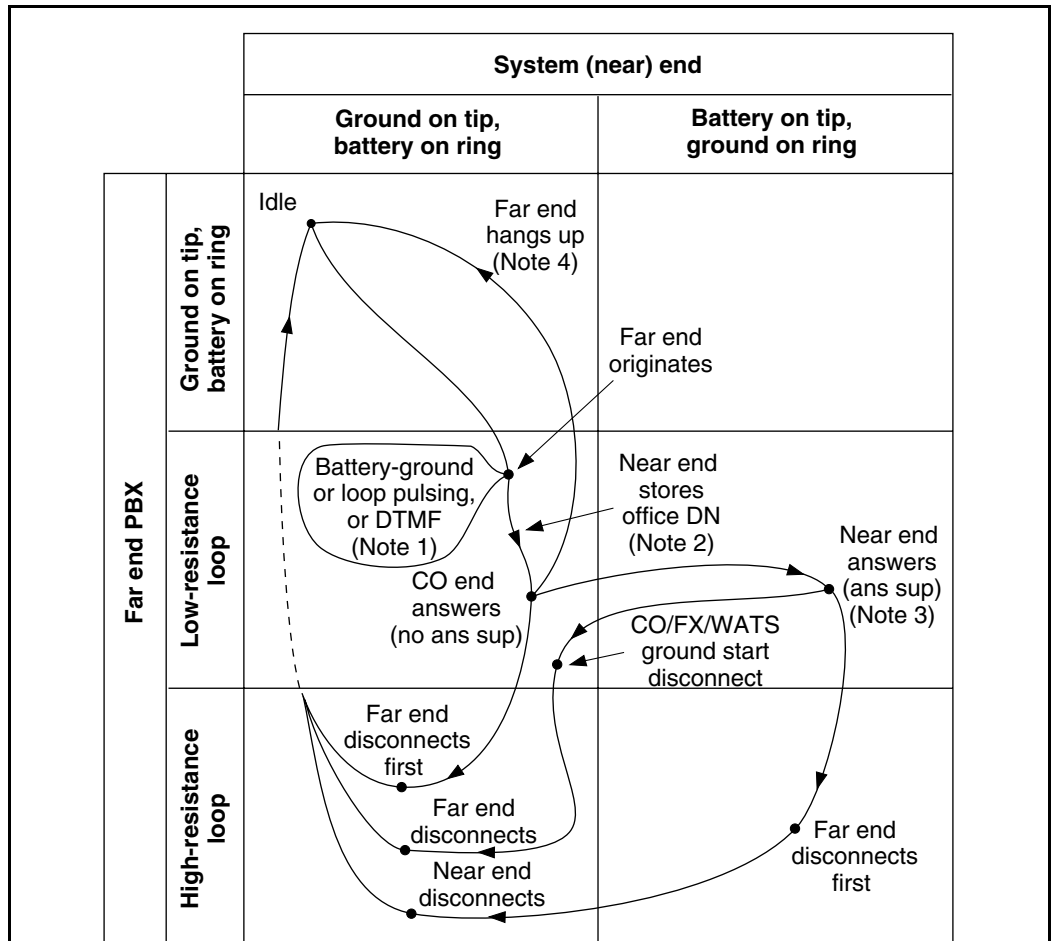
If required, the near-end can be configured to provide pseudo-answer supervision at the expiration of the end-of-dial timer. End-of-dial timer settings are made at the EOD (non-DTMF) or ODT (DTMF) prompts in the Trunk Route Administration program LD 16.

The operation represented in Figure 132 on [page 596](#) also applies to incoming calls on a DID trunk from a CO.

### Outgoing calls

When DDL or WNK mode is used, outgoing calls require a stop/go signal from the far-end so that the near-end cannot outpulse until the far-end is ready to receive digits. See Figure 133 on [page 598](#).

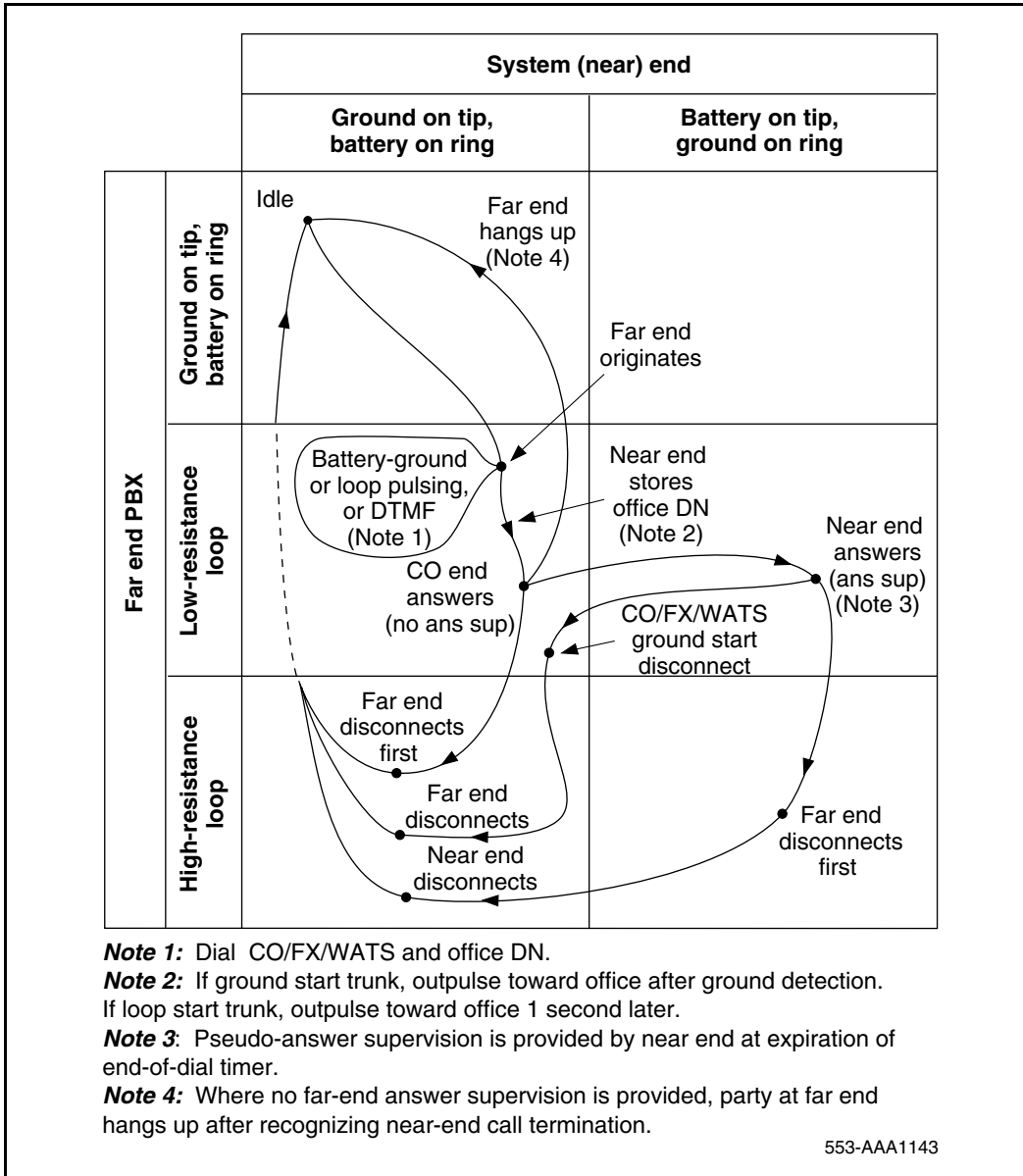
**Figure 131**  
**Two-way, loop DR, TIE trunk call states – incoming call through senderized, tandem PBX from a CO/FX/WATS trunk**



- Note 1:** Dial CO/FX/WATS and office DN.
- Note 2:** If ground start trunk, outpulse toward office after ground detection. If loop start trunk, outpulse toward office 1 second later.
- Note 3:** Pseudo-answer supervision is provided by near end at expiration of end-of-dial timer.
- Note 4:** Where no far-end answer supervision is provided, party at far end hangs up after recognizing near-end call termination.

553-AAA1143

**Figure 132**  
**Two-way, loop DR, TIE trunk call states – incoming call through senderized, tandem PBX from a CO/FX/WATS trunk**



**Note:** Pseudo-answer supervision is provided by near-end at expiration of end-of-dial timer. Where no far-end answer supervision is provided, the party at the far-end hangs up after recognizing near-end call termination.

## **Outgoing automatic, incoming dial operation**

### **Incoming calls**

When the NT8D14 Universal Trunk card is seized by the far-end on an incoming call, a low-resistance loop is placed across the tip and ring leads. Addressing is then sent by the far-end in the form of battery-ground or loop pulses, or DTMF tones. The trunk is released at the far-end when the loop is opened. When the near-end detects an open loop, it returns to a normal state.

See Figure 134 on [page 599](#) and Figure 135 on [page 600](#).

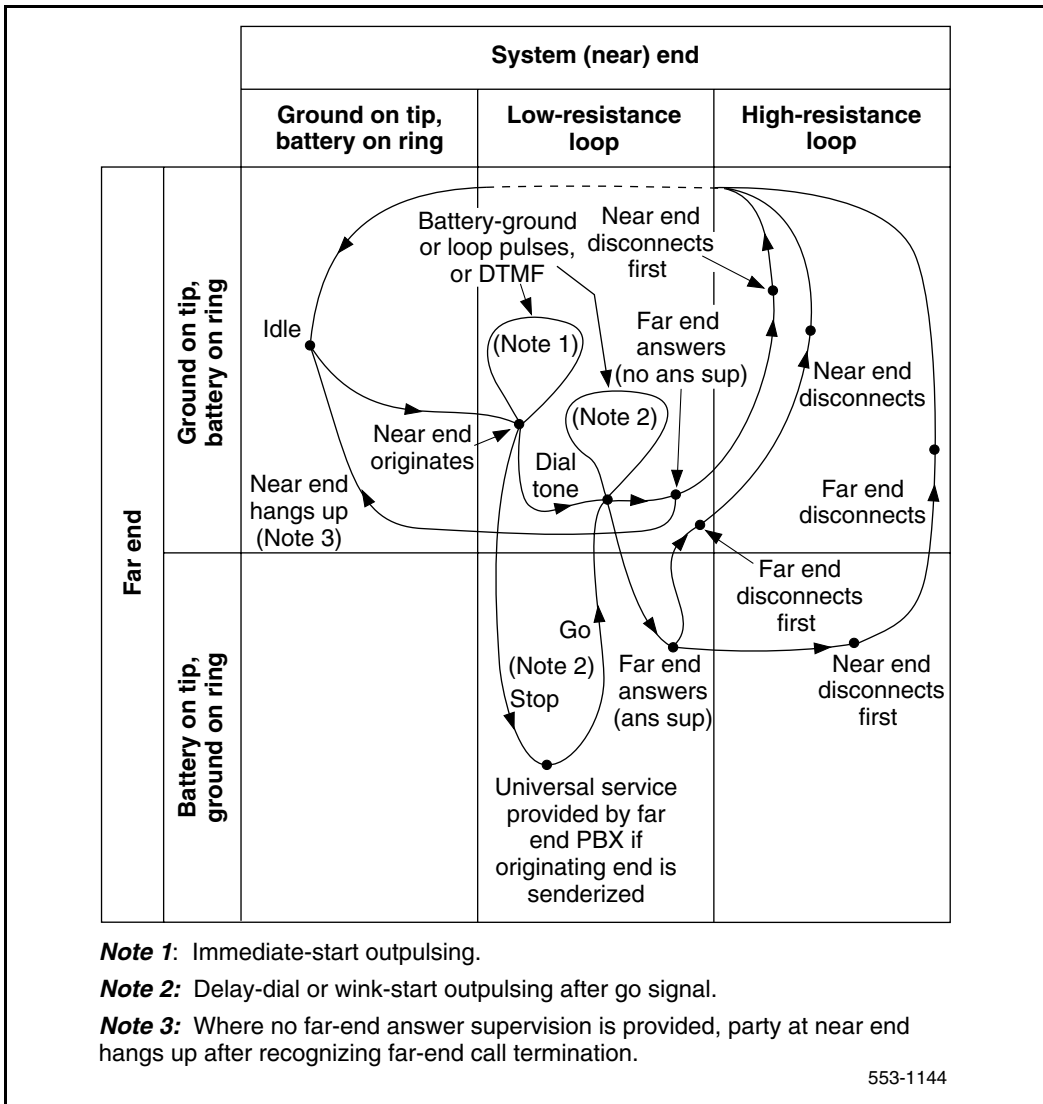
### **Outgoing calls**

When seized as a dial-selected outgoing trunk, the near-end places the battery on the tip and ground on the ring. This alerts the far-end of the seizure. The far-end responds with a low resistance across the tip and ring leads.

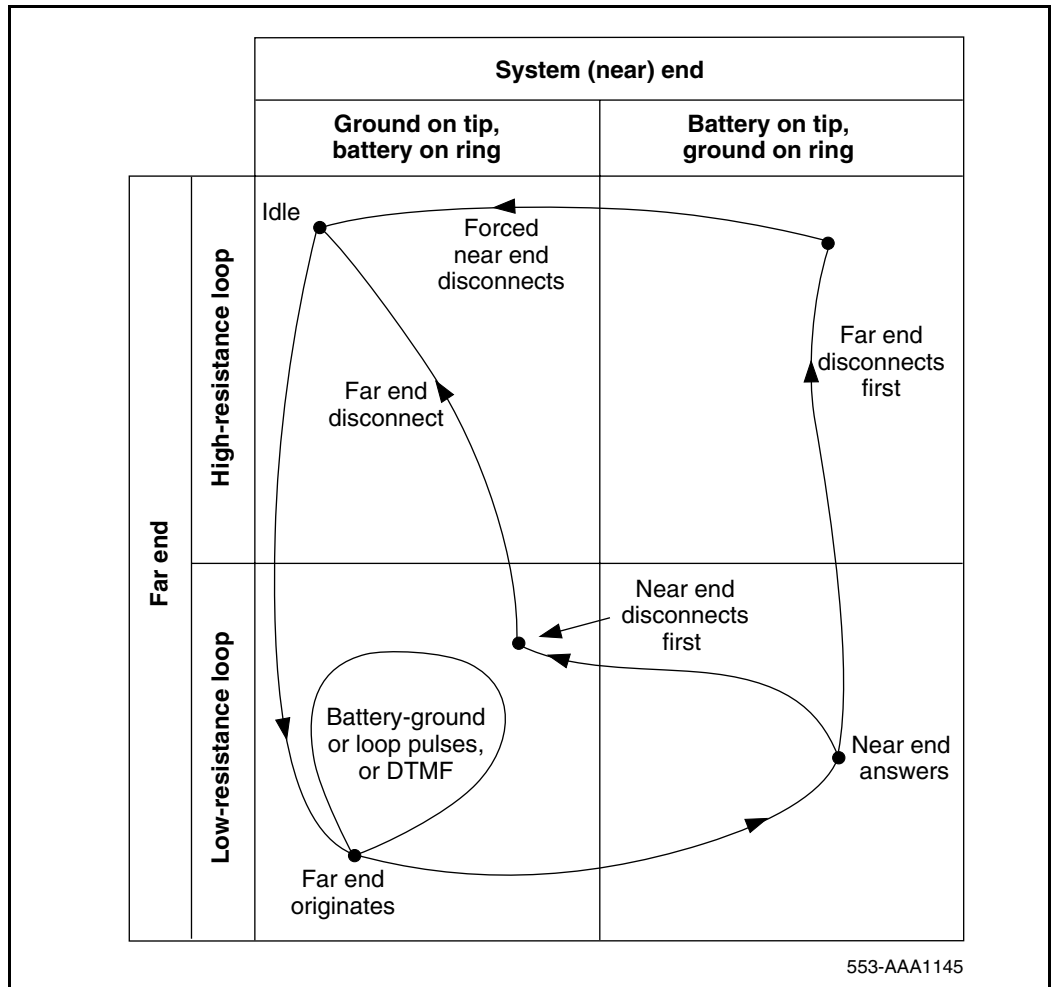
See Figure 136 on [page 601](#) and Figure 137 on [page 602](#).

Figure 133

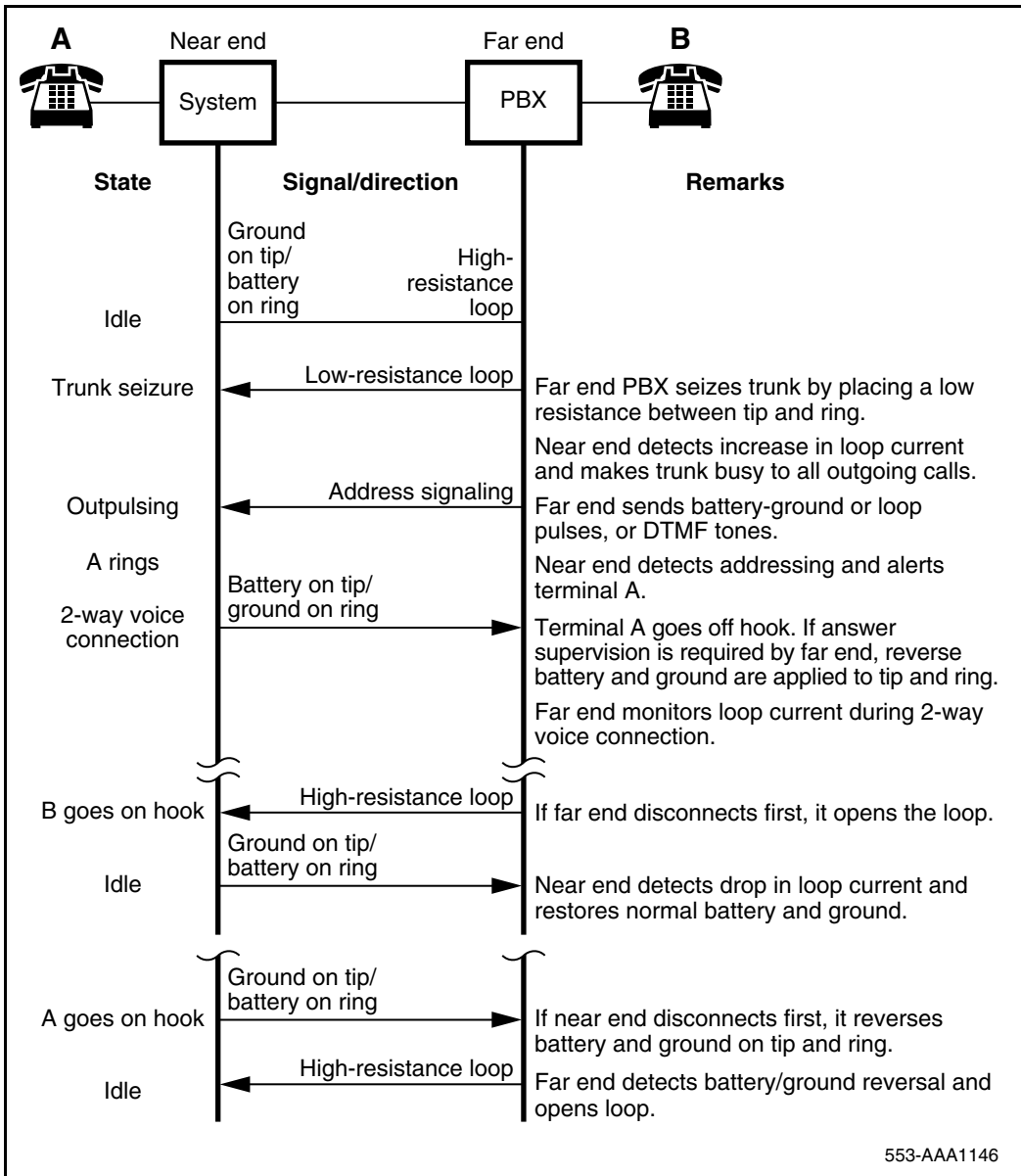
Two-way, loop DR, TIE trunk call states – outgoing call through far-end PBX to CO/FX/WATS



**Figure 134**  
**Two-way, loop OAID, TIE trunk call states – incoming call from far-end PBX**

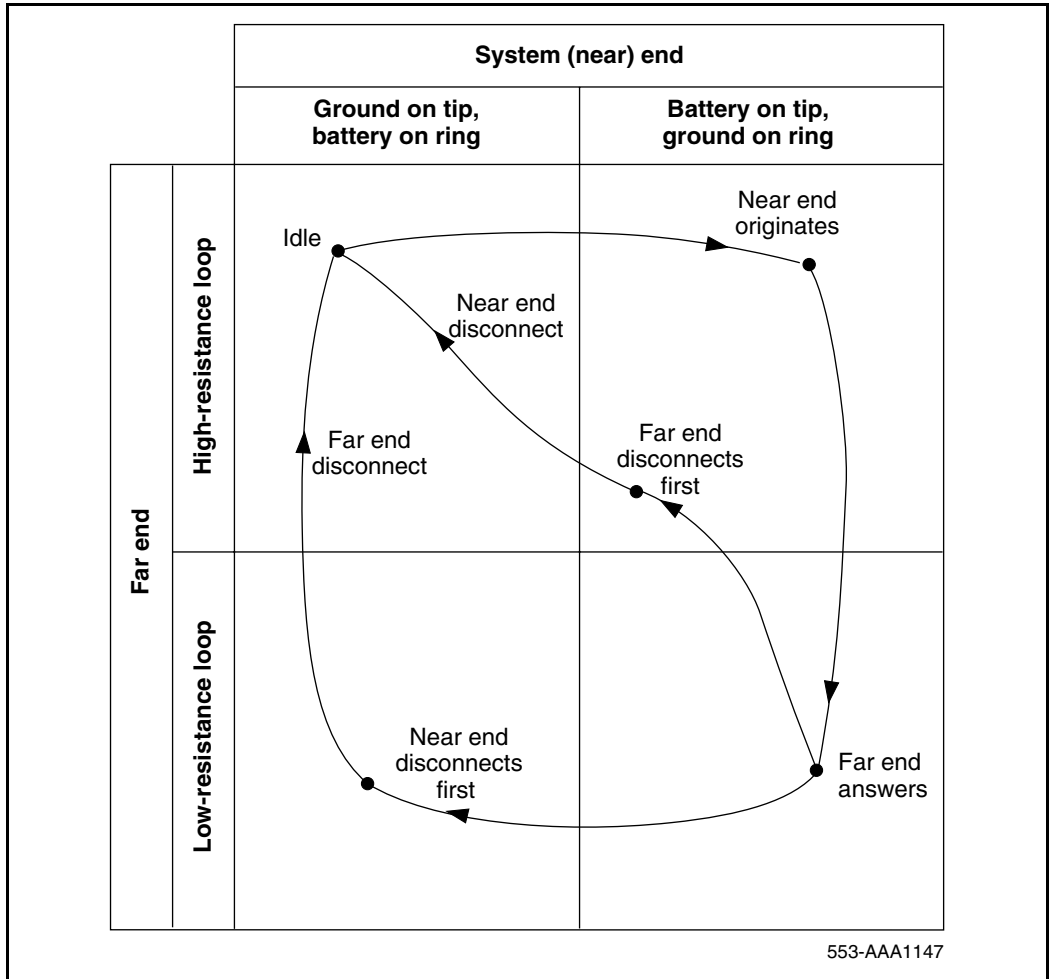


**Figure 135**  
**Two-way, loop OAID, TIE trunk call connection sequence – incoming call from far-end PBX**

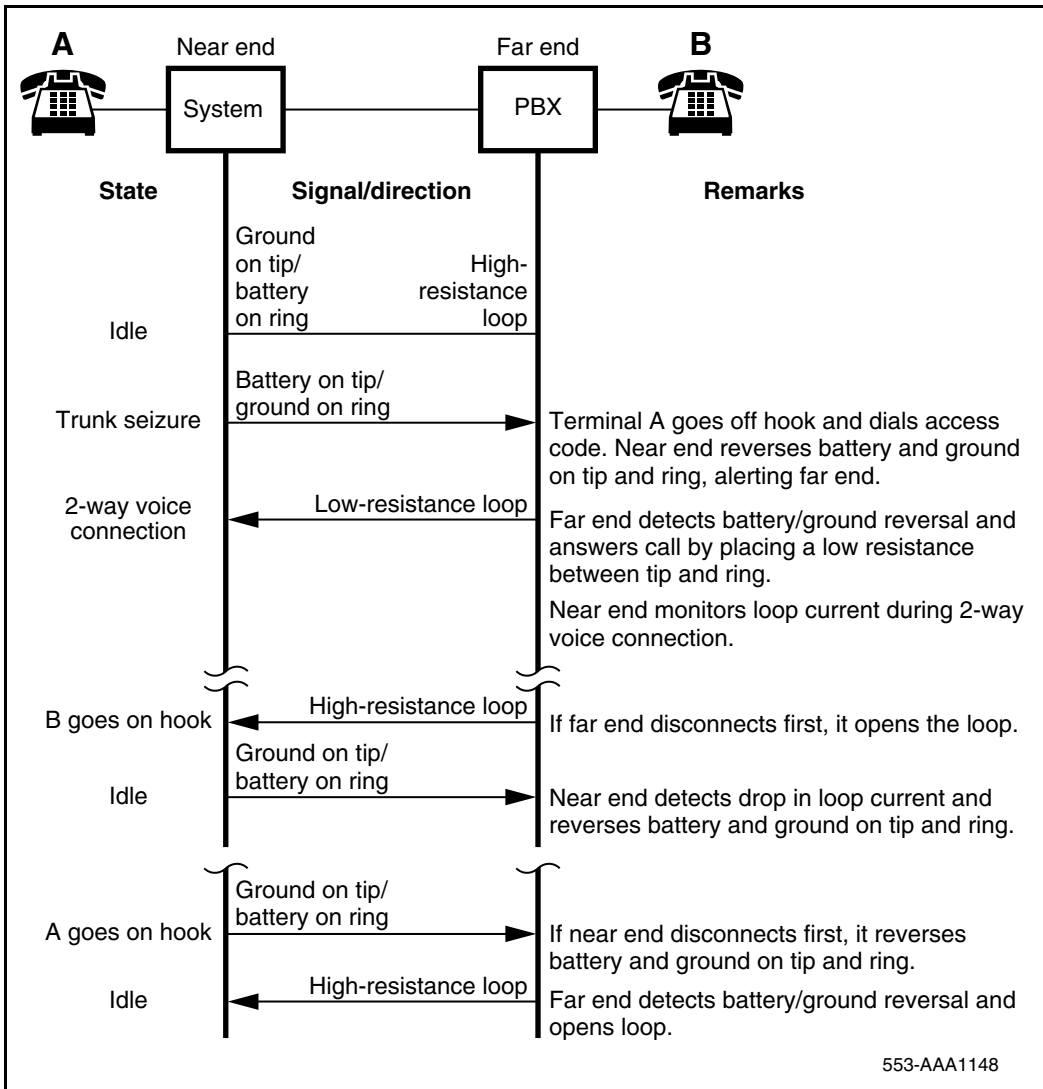




**Figure 136**  
**Two-way, loop OAID, TIE trunk call states – outgoing call to far-end PBX**



**Figure 137**  
**Two-way, loop OAID, TIE trunk call connection sequence – outgoing call to far-end PBX**



## Recorded announcement trunk operation

*Note:* Refer to “Multi-Channel RAN modes” on [page 605](#) for information on Multi-Channel RAN modes, which are not linked to a RAN machine or a given trunk.

When configured for Recorded Announcement (RAN) operation, a trunk unit is connected to a customer-provided recorded announcement machine. Announcement machines must be compatible with RAN trunks. Use the manufacturer’s instructions to set up the Announcement machines.

Each trunk unit provides the following for operation with RAN equipment:

- pulse start, level start, or continuous operation modes
- selectable termination of tip and ring leads into 600 or 900 ohms for interface with a low-impedance (2 or 4 ohms) source
- connection of up to 24 trunk units to a single announcement machine channel

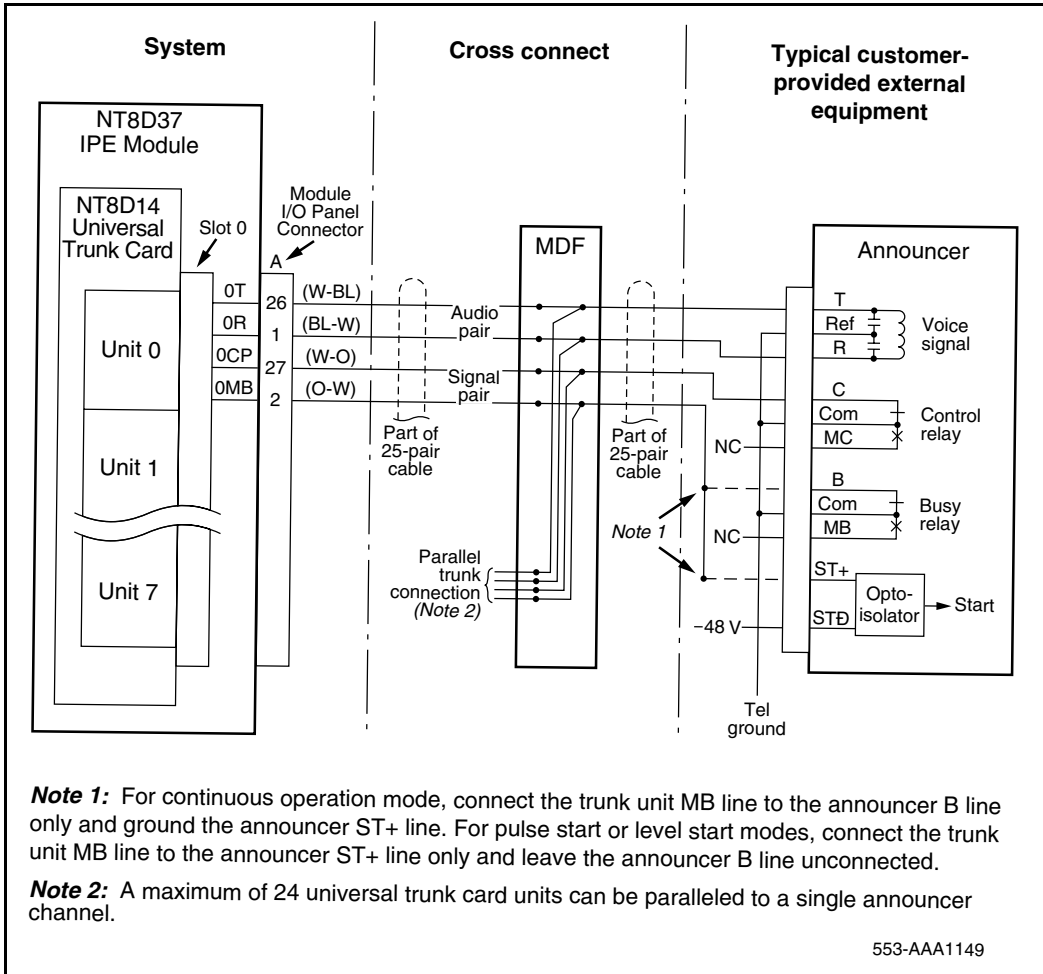
### Recorded announcement machines

Recorded announcement machines store prerecorded voice messages that are played back to the trunk units to which they are connected. Most commercially available announcement machines store recordings digitally, although some drum and tape units are still in service.

An announcement machine can provide one or more channels and each channel may be prerecorded with a different message. Some announcement machines also provide a Special Information Tone (SIT) capability. These tones are inserted at the beginning of intercept messages such as “Your call cannot be completed as dialed. Please check the number and try again.”

Figure 138 on [page 604](#) shows a typical connection from a single announcement machine channel to unit 0 on a universal trunk card.

**Figure 138**  
**Connecting RAN equipment to the NT8D14 Universal Trunk card (typical)**



## **RAN modes of operation**

Figure 139 on [page 606](#) shows the relationship of control signals to message playback for the operating modes available in announcement machines. The signal names shown in Figure 139 are typical.

**Note 1:** For continuous operation mode, connect the trunk unit MB line to the announcer B line only, and ground the announcer ST+ line. For pulse start or level start modes, connect the trunk unit MB line to the announcer ST+ line only, and leave the announcer B line unconnected.

**Note 2:** A maximum of 24 universal trunk card units can be paralleled to a single announcer channel.

## **Multi-Channel RAN modes**

In Multi-Channel RAN, multiple RAN channels can be configured within one RAN trunk route. In a Multi-Channel RAN route, each trunk has its own dedicated RAN channel on a physical RAN machine. Multi-Channel RAN routes do not support the cross connecting (daisy chains) of multiple trunk ports together so that several callers hear the same RAN message.

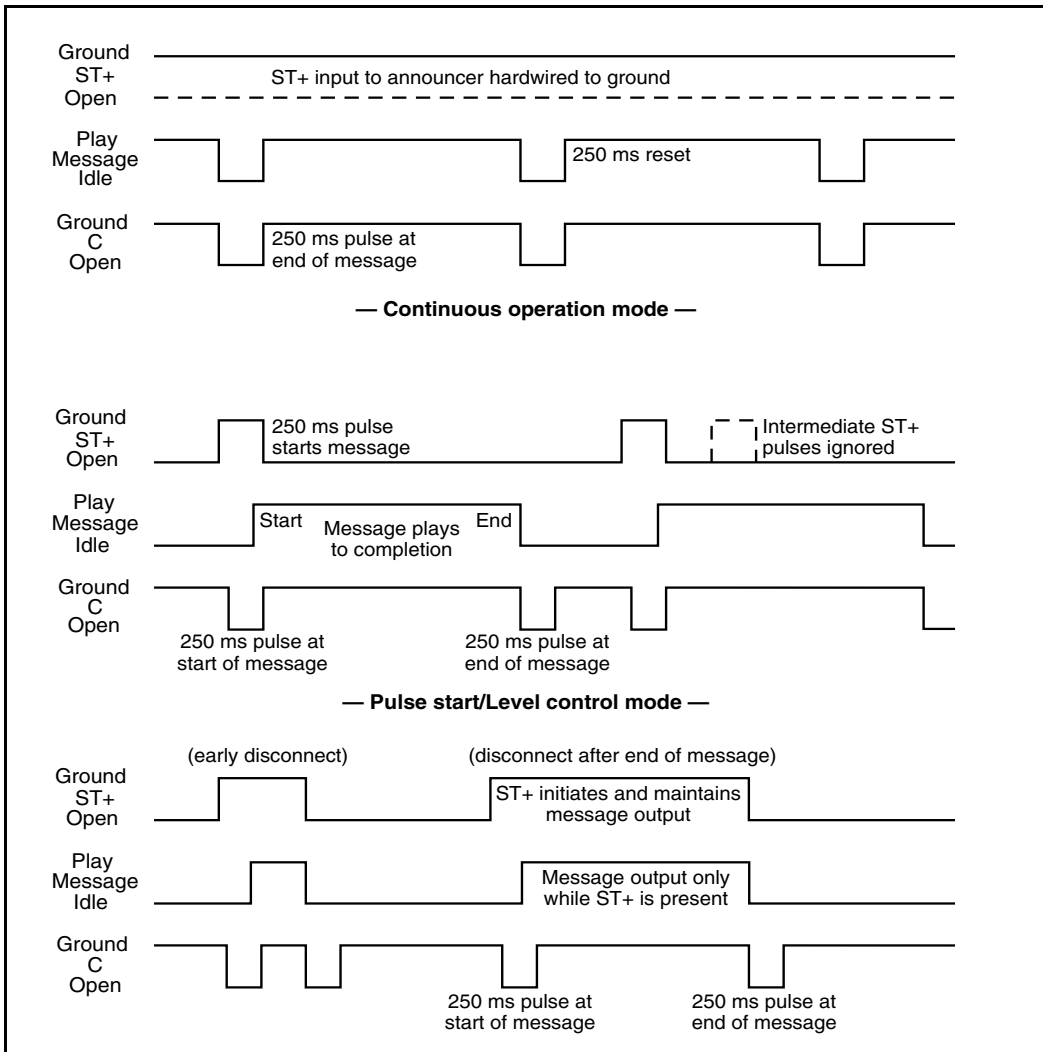
Multi-channel machine types – Continuous Mode Multi-Channel (MCON), Pulse Start/Stop Multi-Channel (MPUL) and Level Start/Stop Multi-Channel (MLVL) – are not linked to a RAN machine or a given trunk. All trunks belonging to the RAN route are considered independent. RAN trunks and RAN machine channels are connected one-to-one. If one RAN trunk is detected as faulty, then all other trunks are not impacted.

For the RAN machine types, the maximum length of the recorded announcement is two hours. The meaning of a ground signal received from the RAN machine (play or idle) is configured in LD 16.

### ***Multi-Channel Level Start/Control Mode (minimum vintage BA)***

A RAN mode of operation is available called “Multi-Channel Level Start/Control Mode.” This mode enables provisioning of multiple RAN channels for a RAN route (playing the same message independently on demand) cross-connected one-to-one to each RAN trunk in a multi-channel level start RAN route. Do not bridge RAN trunks in a multi-channel RAN route.

**Figure 139**  
**RAN control signals (Control GRD = IDLE)**



The Route Data Block LD 16 is used to configure a RAN route in Multi-Channel Level Start/Control mode, using the following response:

**RTYP = MLSS**

Trunk members are provisioned in the Trunk Data Block LD 14.

Refer to “Programming RAN trunks” on [page 608](#) and to *Software Input/Output: Administration* (553-3001-311) for instructions on service change programs.

### ***Continuous operation mode***

In the continuous operation mode (sometimes called the Audichron mode), a message is constantly played, over and over again. Callers “barge in” on a playing message or receive a ringback tone until the message plays again. The start line (ST+) is hardwired as always active. See Figure 139 on [page 606](#). At the end of each message, a pulse is issued on the “C” line that is used by the trunk unit to cut through to the waiting call.

**Note:** The “B” (busy) signal line indicates availability of an announcement machine message to the trunk unit when configured for the continuous operation mode. This signal is made active (ground) by the announcement machine if the channel contains a recorded message and is in an online condition. The “B” line is not connected to a trunk unit when configured for start mode operation.

### ***Start modes (minimum vintage BA)***

In a start mode (sometimes called the Code-a-Phone or start-stop mode), playback of a message does not begin until a start pulse is received by the announcement machine. Two subcategories of the start mode exist: pulse start and level start.

In the pulse start mode, a start pulse activates playback of a message that continues until completion. The announcement machine ignores all other start pulses that might occur until the message is complete.

In the level start mode, the start signal is a “level” rather than a pulse. The leading edge of the start signal initiates message playback that continues until either the trailing edge of the start signal occurs or the end of the message is reached. A message that is terminated by the trailing edge of a level start signal is immediately reset and ready for playback again.

### **Call routing to RAN trunks**

CS 1000 Release 4.5 software controls recorded announcement machines. These programs detect the calls to be intercepted, determine the type of intercept treatment required (for example, overflow, attendant, announcement), queue the intercept, and provide ringback tone to the calling party. At the proper time, an intercepted call is connected to the appropriate RAN trunk.

### **Programming RAN trunks**

The type of intercept and the RAN trunk parameters are defined in the Trunk Data Block LD 14, Customer Data Block LD 15, and Route Data Block LD 16 programs.

The Trunk Data Block and Route Data Block programs specify the following:

- the RAN trunk
- the type of announcement machine
- the number of repetitions of announcements before a forced disconnect (all calls) or an attendant intercept is initiated (CCSA/DID calls only)
- the point at which the trunk may be connected to the announcement

The Customer Data Block program defines the type of intercept and the trunk route to which the intercept is to be connected.

Refer to *Software Input/Output: Administration* (553-3001-311) for instructions on service change programs.



## Electrical specifications

Table 185 gives the electrical characteristics of the NT8D14 Universal Trunk card.

**Table 185**  
**Universal trunk card – trunk interface electrical characteristics (Part 1 of 2)**

Characteristic	Trunk Types			
	CO / FX / WATS	DID / TIE	RAN	Paging
Terminal impedance	600 or 900 ohms (Note 1)	600 or 900 ohms (Note 1)	600/900 ohms (Note 1)	600 ohms
Balance impedance	600 or 900 ohms (Note 1), 3COM, or 3CM2 (Note 2)	600 or 900 ohms (Note 1), 3COM, or 3CM2 (Note 2)	N/A	N/A
Supervision type	Ground or loop start (Note 3)	Loop start (with ans sup) (Note 3)	Continuous, level, or pulse	N/A
DC signaling loop length (max)	1700-ohm loop with near-end battery of –42.75 V	2450-ohm loop with near-end battery of –44 V	600/900-ohm loop	600 ohm loop
Far-end battery	–42 to –52.5 V (Note 4)	–42 to –52.5 V	–42 to –52 V	N/A
Minimum detected loop current	20 mA	10 mA	10 mA	N/A
Ground potential difference	±3 V	±3 V	±1 V	±1 V
Low DC loop resistance during outpulsing	<300 ohms	N/A	N/A	N/A
High DC loop resistance	Ground start Š 30k ohms; loop start Š 5M ohms	N/A	N/A	N/A
Ring detection	17 to 33 Hz 40 to 120 V rms	N/A	N/A	N/A

**Table 185**  
**Universal trunk card – trunk interface electrical characteristics (Part 2 of 2)**

Trunk Types				
Characteristic	CO / FX / WATS	DID / TIE	RAN	Paging
Line leakage	Š 30k ohms, tip-to-ring, tip-to-ground, ring-to-ground	Š 30k ohms, tip-to-ring, tip-to-ground, ring-to-ground	N/A	N/A
AC induction rejection	10 V rms, tip-to-ring, tip-to-ground, ring-to-ground	10 V rms, tip-to-ring, tip-to-ground, ring-to-ground	N/A	N/A
Selected in software. Selected by jumper strap settings on card. Refer to Tables 190, 191, and 192 for details. For loop extender application, the maximum voltage applied between tip and ring is –105 V ±5%. The minimum dc loop resistance for this type of application is 1800 ohms.				

## Power requirements

Power to the NT8D14 Universal Trunk card is provided by the module power supply (ac or dc).

**Table 186**  
**Power requirements for universal trunk card**

Voltage	Tolerance	Current (max.)
+15.0 V dc	±5%	306 mA
–15.0 V dc	±5%	306 mA
+5.0 V dc	±5%	750 mA
+8.5 V dc	±2%	450 mA
–48.0 V dc	±5%	415 mA

## Foreign and surge voltage protection

The NT8D14 Universal Trunk card meets UL-1489 and CS03 over-voltage (power cross) specifications and FCC Part 68 requirements.

## Environmental specifications

Table 187 lists the environmental specifications for the NT8D14 Universal Trunk card.

**Table 187**  
**Environmental specifications for the NT8D14 Universal Trunk card**

Parameter	Specifications
Operating temperature	0° to +60° C (+32 to +140° F), ambient 0 to 50 degrees C, ambient (Small Systems and CS 1000S)
Operating humidity	5 to 95% RH (non-condensing)
Storage temperature	-40° to +70° C (-40° to +158° F)

## Release control

Release control establishes which end of a call (near, far, either, joint, or originating) disconnects the call. Only incoming trunks in idle ground start configuration can provide disconnect supervision. You configure release control for each trunk independently in the Route Data Block (LD 16).

## PAD switching

The transmission properties of each trunk are characterized by the class-of-service (COS) you assign in the Trunk Data Block (LD 14). Transmission properties may be via net loss (VNL) or non via net loss (non-VNL).

Non-VNL trunks are assigned either a Transmission Compensated (TRC) or Non-Transmission Compensated (NTC) class-of-service to ensure stability and minimize echo when connecting to long-haul trunks, such as Tie trunks.

The class-of-service determines the operation of the switchable PADs contained in each unit. They are assigned as follows:

- Transmission Compensated
  - used for a two-wire non-VNL trunk facility with a loss of greater than 2 dB for which impedance compensation is provided
  - or used for a four-wire non-VNL facility
- Non-Transmission Compensated
  - used for a two-wire non-VNL trunk facility with a loss of less than 2 dB
  - or used when impedance compensation is not provided

The insertion loss from IPE ports to IPE ports is as follows:

**Table 188**  
**Insertion Loss from IPE Ports to IPE Ports (measured in dB)**

		IPE Ports									
		500/2500 Line	Digital Line		2/4 Wire E&M Trunk		4 Wire (ESN) E&M Trunk		CO/FX /WATS Loop Tie Trunk		
IPE Ports		↑	↑	↓	↑	↓	↑	↓	↑	↓	
CO/FX/ WATS Loop Tie Trunk	→	2.5	0		0.5		0		0.5		
	←	0	-3.5		0		-0.5		0.5		

## Connector pin assignments

The universal trunk card connects the eight analog trunks to the backplane through a 160-pin connector shroud. Telephone trunks connect to the universal trunk card at the back of the MG 1000S using a 25-pin connector.

A list of the connections to the universal trunk card is shown in Table 189 on [page 614](#). See *Communication Server 1000S: Installation and Configuration* (553-3031-210) for I/O panel connector information and wire assignments for each tip/ring pair.

**Table 189**  
**Universal trunk card – backplane pinouts (Part 1 of 2)**

Trunk Number	Back-plane Pin	Signal			Back-plane Pin	Signal		
		RAN mode	Paging mode	Other modes		RAN mode	Paging mode	Other modes
0	12A	Tip	Tip	Tip	12B	Ring	Ring	Ring
	13A	CP	A	N/A	13B	MB	RG	N/A
1	14A	Tip	Tip	Tip	14B	Ring	Ring	Ring
	15A	CP	A	N/A	15B	MB	RG	N/A
2	16A	Tip	Tip	Tip	16B	Ring	Ring	Ring
	17A	CP	A	N/A	17B	MB	RG	N/A
3	18A	Tip	Tip	Tip	18B	Ring	Ring	Ring
	19A	CP	A	N/A	19B	MB	RG	N/A
4	62A	Tip	Tip	Tip	62B	Ring	Ring	Ring
	63A	CP	A	N/A	63B	MB	RG	N/A
5	64A	Tip	Tip	Tip	64B	Ring	Ring	Ring
	65A	CP	A	N/A	65B	MB	RG	N/A
6	66A	Tip	Tip	Tip	66B	Ring	Ring	Ring
	67A	CP	A	N/A	67B	MB	RG	N/A

**Table 189**  
**Universal trunk card – backplane pinouts (Part 2 of 2)**

Trunk Number	Back-plane Pin	Signal			Back-plane Pin	Signal		
		RAN mode	Paging mode	Other modes		RAN mode	Paging mode	Other modes
7	68A	Tip	Tip	Tip	68B	Ring	Ring	Ring
	69A	CP	A	N/A	69B	MB	RG	N/A

## Configuration

The trunk type for each unit on the card as well as its terminating impedance and balance network configuration is selected by software service change entries at the system terminal and by jumper strap settings on the card.

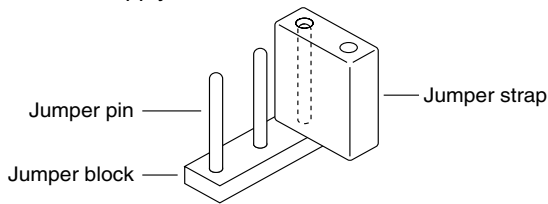
NT8D14 has a reduced jumper strap setting on the card. There are only three jumpers, J1.X, J2.X, and J3.X on each channel. Tables 190, 191, and 192 show the functionality of these three jumpers.

**Table 190**  
**Jumper strap settings – factory standard (NT8D14BA, NT8D14BB)**

Trunk types		Loop length	Jumper strap settings (Note 1)			
			J1.X	J2.X	J3.X	J4.X (Note 2)
CO/FX/WATS	0–1524 m (5000 ft.)	0–600 ohms	Off	Off	1–2	1–2
2-way TIE (LDR)						
2-way TIE (OAID)						
DID			Off	Off	1–2	1–2
RAN: continuous operation mode	Not applicable: RAN and paging trunks should not leave the building.		Off	Off	1–2	1–2
Paging						

**Note 1:** Jumper strap settings J1.X, J2.X, J3.X, and J4.X apply to all eight units; “X” indicates the unit number, 0–7. “Off” indicates that no jumper strap is installed on a jumper block. Store unused straps on the universal trunk card by installing them on a single jumper pin as shown below.

**Note 2:** For the NT8D14BB card, J4.X is not provided on the card. The J4.X jumper setting specified in Table 190 does not apply.



553-6317



**Table 191**  
**Jumper strap settings – extended range (NT8D14BA, NT8D14BB, NT8D14BB)**

Trunk types		Jumper strap settings (Note 1)			
		J1.X	J2.X	J3.X	J4.X (Note 2)
CO/FX/WATS	> 1524 m (5000 ft.)	Off	Off	1–2	2–3
2-way TIE (LDR)					
2-way TIE (OAID)					
DID	> 600 ohms	On	On	1–2	2–3
RAN: pulse start or level start modes	Not applicable: RAN trunks should not leave the building.	Off	Off	2–3	1–2
<p><b>Note 1:</b> Jumper strap settings J1.X, J2.X, J3.X, and J4.X apply to all eight units; “X” indicates the unit number, 0–7. “Off” indicates that no jumper strap is installed on a jumper block.</p> <p><b>Note 2:</b> For the NT8D14BB card, J4.X is not provided on the board. The J4.X jumper setting specified in Table 191 does not apply.</p>					

Table 192

Trunk types – termination impedance and balance network (NT8D14BA, NT8D14BB)

Trunk types	Terminating impedance (Note 1)	Balance network for loop lengths (Note 2)		
		0–915 m (0–3000 ft)	915–1524 m (3000–5000 ft)	> 1524 m (> 5000 ft)
CO/FX/WATS	600 or 900 ohms	600 ohms	3COM	3CM2
2-way TIE (LDR)	600 or 900 ohms	600 ohms	3COM	3CM2
2-way TIE (OAID)	600 or 900 ohms	600 ohms	3COM	3CM2
DID (loop length < 600 ohms)	600 or 900 ohms	600 ohms	3COM	3CM2
DID (loop length $\geq$ 600 ohms)	600 or 900 ohms	600 ohms	N/A	3CM2
RAN: continuous operation mode	600 or 900 ohms	600 or 900 ohms	N/A	N/A
Paging	600 ohms	600 ohms	N/A	N/A

**Note 1:** The terminating impedance of each trunk unit is software selectable in LD 14 and should match the nominal impedance of the connecting equipment.

**Note 2:** The balance network of each trunk unit is software selectable between resistive 600 or 900 ohms or 3COM and jumper selectable between 3COM and 3CM2. Jumper selection for 3COM/3CM2 restriction does not apply to NT8D14BB.

## Jumper strap settings

For most applications, the jumper strap settings remain set to the standard configuration as shipped from the factory. See Table 190 on [page 616](#).

The jumper strap settings must be changed, as shown in Table 191 on [page 617](#), for the following:

- For CO/FX/WATS or TIE trunk loops exceeding 1524 meters (5000 ft.)

- DID trunks exceeding a loop resistance of 600 ohms
- RAN trunks operating in pulse start or level start modes

Figure 140 on [page 620](#) shows jumper locations on the universal trunk card (vintage BA).

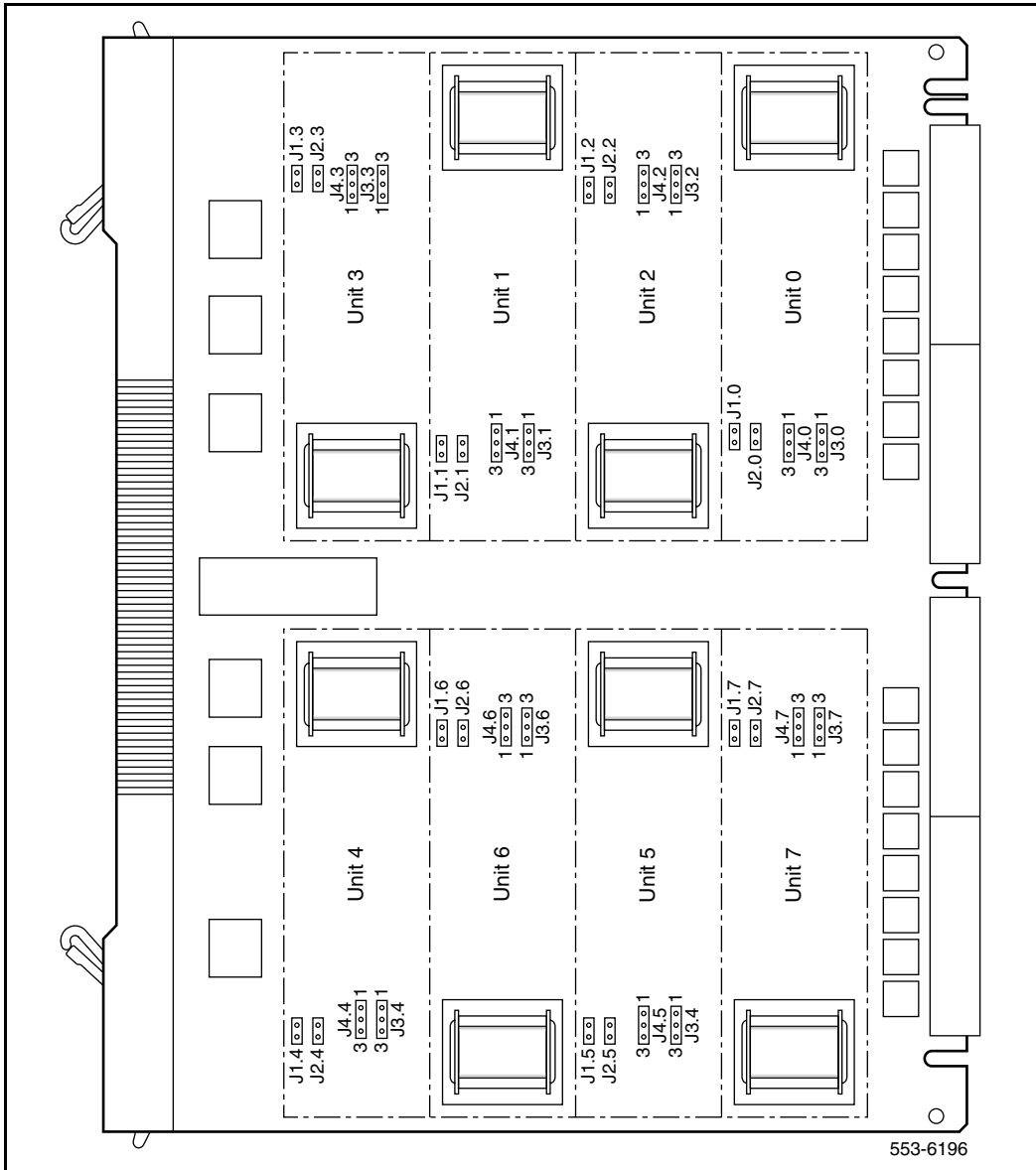
## Service change entries

The trunk type, terminating impedance, and balance network are selected by making service change entries in the Trunk Administration program LD 14.

See Table 193 on [page 621](#) for the proper values for the trunk type and loop length. Refer to *Software Input/Output: Administration* (553-3001-311) for LD 14 service change instructions.

Before the appropriate balance network can be selected, the loop length between the near-end and the far-end (a Central Office, for example) must be known. To assist in determining loop length, some typical resistance and loss values for the most common cable lengths are given in Table 194 on [page 622](#) for comparison with values obtained from actual measurements.

**Figure 140**  
**Universal trunk card – jumper locations (for NT8D14BA, NT8D14BB Release 9 and below)**



553-6196

**Table 193**  
**Trunk types – termination impedance and balance network (NT8D14BA, NT8D14BB)**

Trunk types		Balance network for loop lengths (Note 2)		
		0–915 m (0–3000 ft)	915–1524 m (3000–5000 ft)	> 1524 m (> 5000 ft)
CO/FX/WATS	600 or 900 ohms	600 ohms	3COM	3CM2
2-way TIE (LDR)	600 or 900 ohms	600 ohms	3COM	3CM2
2-way TIE (OAID)	600 or 900 ohms	600 ohms	3COM	3CM2
DID (loop length < 600 ohms)	600 or 900 ohms	600 ohms	3COM	3CM2
DID (loop length ≥ 600 ohms)	600 or 900 ohms	600 ohms	N/A	3CM2
RAN: continuous operation mode	600 or 900 ohms	600 or 900 ohms	N/A	N/A
Paging	600 ohms	600 ohms	N/A	N/A
<p><b>Note 1:</b> The terminating impedance of each trunk unit is software selectable in LD 14 and should match the nominal impedance of the connecting equipment.</p> <p><b>Note 2:</b> The balance network of each trunk unit is software selectable between resistive 600 or 900 ohms or 3COM and jumper selectable between 3COM and 3CM2. Jumper selection for 3COM/3CM2 restriction does not apply to NT8D14BB.</p>				

**Table 194**  
**Cable loop resistance and loss**

Cable length	Cable loop resistance (ohms)			Cable loop loss (dB) (nonloaded at 1kHz)		
	22 AWG	24 AWG	26 AWG	22 AWG	24 AWG	26 AWG
915 m (3000 ft.)	97	155	251	0.9	1.2	1.5
1524 m (5000 ft.)	162	260	417	1.6	2.0	2.5
2225 m (7300 ft.)	236	378	609	2.3	3.0	3.7
3566 m (11700 ft.)	379	607	977	3.7	4.8	6.0
5639 m (18500 ft.)	600	960	1544	5.9	7.6	9.4

**Port-to-port loss configuration**

Loss parameters are selected on the NT8D14 Universal Trunk card by a switchable pad controlled by codec emulation software. For convenience, the pads settings are called “in” and “out.” Pad settings are determined by the two factors listed below (the first is under direct user control; the second is controlled indirectly):

- Class of Service is assigned in LD 14 (under direct user control).
- Port-to-port connection loss is automatically set by software on the basis of the port type selected in LD 16; only the port type is set by the user (controlled indirectly).

The transmission properties of each trunk are characterized by the class of service assigned in LD 14. Transmission properties can be Via Net Loss (VNL) or non-Via Net Loss (non-VNL).

The VNL class of service is assigned at the prompt CLS with the response VNL. The non-VNL class of service is assigned at prompt CLS by selecting either the Transmission Compensated (TRC) or Non-Transmission Compensated (NTC) response.

Non-VNL trunks are assigned a TRC or NTC class of service to ensure stability and minimize echo when connecting to long-haul trunks, such as Tie

trunks. The class of service determines the operation of the switchable pads contained in each unit. They are assigned as follows:

- TRC for a 2-wire non-VNL trunk facility with a loss of greater than 2 dB, or for which impedance compensation is provided, or for a 4-wire non-VNL facility.
- NTC for a 2-wire, non-VNL trunk facility with a loss of less than 2 dB, or when impedance compensation is not provided.

See Table 195 for the pad switching control for the various through connections and the actual port-to-port loss introduced for connections between the NT8D14 Universal Trunk card and any other port designated as Port B.

**Table 195**  
**Pad switching algorithm**

Port B	Port B pads		Universal Trunk Pads		Port-to-port loss (dB)	
	Transmit D to A	Receive A to D	Transmit D to A	Receive A to D	Port B to Universal trunk card	Universal trunk card to Port B
IPE line	N/A	N/A	Out	Out	0.5	0.5
Universal trunk (TRC)	In	Out	In	Out	1	1
IPE TIE (VNL)	In	In	Out	Out	0	0

**Note:** Transmit and receive designations are from and to the system. Transmit is from the system to the external facility (digital-to-analog direction in the Universal trunk card). Receive is to the system from the external facility (analog-to-digital direction in the Universal trunk card).

**Note:** When Port B is the call originating port. If the Universal trunk card is the originating port, the UTC pads are out, the Port B (PE CO/FX/WATS) pads are in.

## Applications

The optional applications, features, and signaling arrangements for each trunk are assigned through unique route and trunk data blocks.

### Paging trunk operation

A universal trunk card unit can be configured as a paging trunk. Configure units as paging trunks in the Trunk Data Block program LD 14 and assign routes in the Route Data Block program LD 16.

Figure 141 on [page 625](#) shows a typical connection from customer-provided equipment to unit 0 on a universal trunk card that can be installed in slots 1, 2, and 3 in an MG 1000S, and slots 7, 8, 9, and 10 in an MG 1000S. See *Communication Server 1000S: Installation and Configuration* (553-3031-210) for trunk wiring information.

### Music operation

A trunk unit can be connected to a music source. The audio source should provide an adjustable power output at 600 ohms.

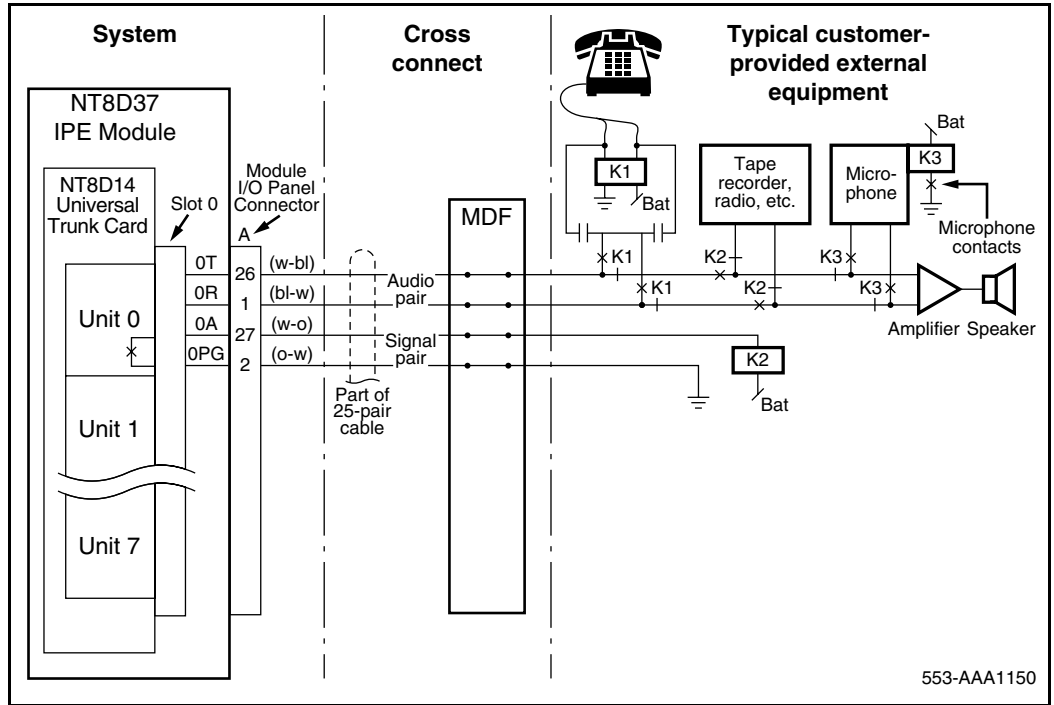
Configure units for music at the MUS or AWR prompts in the Trunk Administration program LD 14 and assign routes at the MRT prompt in the Route Data Block program LD 16.

Music operation is similar to that of RAN in the continuous operation mode. Connect the unit tip and ring leads to the audio source and ground the CP line at the MDF.

If the music source is equipped with contacts that close when music is online, use these contacts to provide a ground to the MB line; otherwise, ground the MB line at the MDF.



**Figure 141**  
**Connecting paging equipment to the NT8D14 Universal Trunk card (typical)**





---

# NT8D15 E&M Trunk card

---

## Contents

This section contains information on the following topics:

Introduction . . . . .	627
Physical description . . . . .	629
Functional description . . . . .	631
Operation . . . . .	641
Electrical specifications . . . . .	652
Connector pin assignments . . . . .	655
Configuration . . . . .	658
Applications . . . . .	664

## Introduction

The NT8D15 E&M trunk card interfaces four analog telephone trunks to the switch. Each trunk interface connects to a trunk facility using tip and ring leads that carry voice, ringing, and tone signaling, and to signaling interfaces by E&M leads. Each unit can be configured independently by software control in the Trunk Data Block (or Trunk Administration) program LD 14.

You can install this card in any IPE slot.

**Note:** Up to four analog trunk cards are supported in each MG 1000S and four analog trunk cards in each MG 1000S Expansion.

*Note:* In Cabinet systems equipped with Meridian Mail, the Universal Trunk line card cannot be installed in slot 10 of the main cabinet.

The NT8D15 E&M trunk card supports the following types of trunks:

- 2-wire E&M Type I signaling trunks
- two-wire dial repeating trunks
- two or four wire tie trunks
- 4-wire E&M trunks:
  - Type I or Type II signaling
  - duplex (DX) signaling
- paging (PAG) trunks

Type I signaling uses two signaling wires plus ground. Type II and DX signaling uses two pairs of signaling wires. Most electronic switching systems use Type II signaling.

Table 196 lists the signaling and trunk types supported by the NT8D15 E&M trunk card.

**Table 196**  
**Trunk and signaling matrix**

Signaling	Trunk types			
	RLM/RLR	TIE	PAG	CSA/CAA/CAM
2-wire E&M	Yes	Yes	Yes	Yes
4-wire E&M	Yes	Yes	No	Yes
Legend: RLM Release Link Main RLR Release Link Remote CSA Common Control Switching Arrangement CAA Common Control Switching Arrangement with Automatic Number Identification (ANI) CAM Centralized Automatic Message Accounting (CAMA) trunk				

## Physical description

The line interface and common multiplexing circuitry is mounted on a 31.75 cm by 25.40 cm (12.5 in. by 10 in.) printed circuit board.

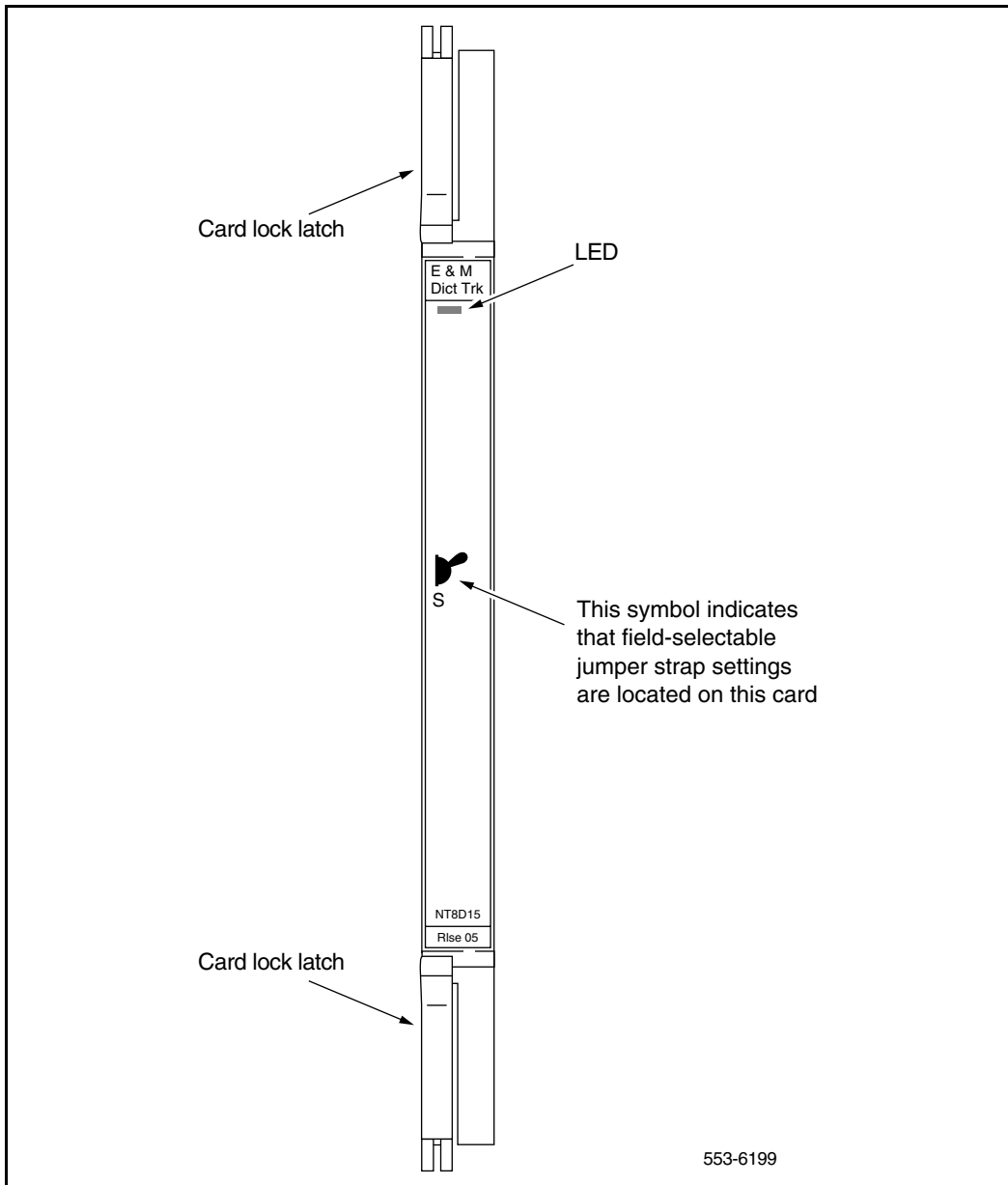
The E&M trunk card connects to the backplane through a 160-pin connector shroud. External equipment connects to the card at the back of the MG 1000S using a 25-pin connector. Telephone lines from station equipment cross connect to the OPS analog line card at the MDF using a wiring plan similar to that used for line cards. See *Communication Server 1000S: Installation and Configuration* (553-3031-210) for termination and cross connect information.

Each card provides four circuits. Each circuit connects with the switching system and with the external apparatus by an 80-pin connector at the rear of the pack. Each trunk circuit on the card connects to trunk facilities by tip and ring leads which carry voice, ringing, tone signaling and battery. Trunk option selection is determined by software control in LD 14.

Figure 142 on [page 630](#) illustrates the faceplate of the E&M trunk card. The words “**Dict Trk**” appear on the faceplate label because earlier versions of this card provided dictation trunk connections for third-party equipment.

The faceplate of the card is equipped with a red LED. When an E&M trunk card is installed, the LED remains lit for two to five seconds while the self-test runs. If the self-test completes successfully, the LED flashes three times and remains lit. When the card is configured and enabled in software, then the LED goes out. If the LED continues to flash or remains weakly lit, replace the card.

Figure 142  
E&M trunk card – faceplate



## Functional description

The NT8D15 E&M Trunk card serves various transmission requirements. The trunk circuits on the card can operate in either A-Law or  $\mu$ -Law companding modes. The mode of operation is set by service change entries.

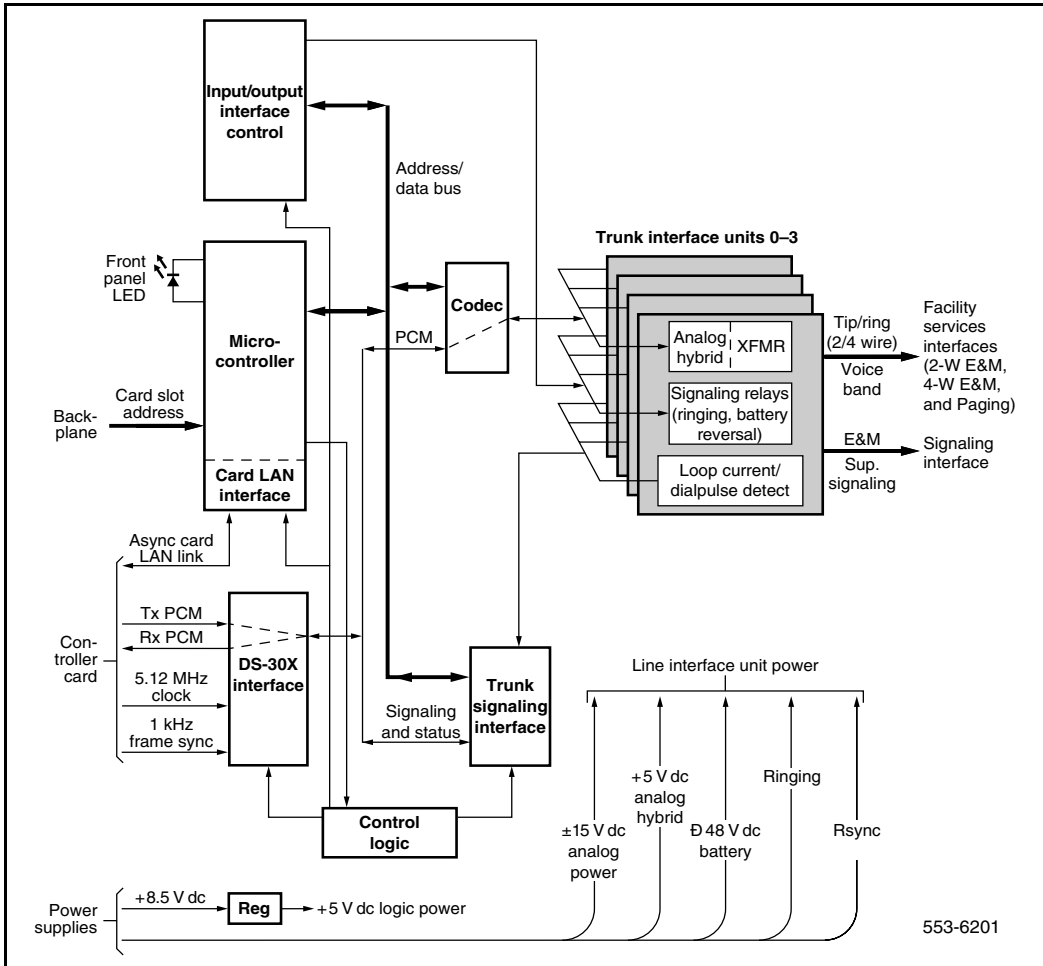
Figure 143 on [page 632](#) shows a block diagram of the major functions contained on the E&M trunk card. Each of these functions is discussed on the following pages.

### Common features

The following features are common to all circuits on the NT8D15 E&M Trunk card:

- Analog-to-digital and digital-to-analog conversion of transmission signals.
- Interfaces each of the four PCM signals to one DS30X timeslot in A10 format.
- Transmit and receive SSD signaling messages over a DS30X signaling channel in A10 format.
- Ability to enable and disable individual ports or the entire card under software control.
- Provides outpulsing on the card. Make break ratios are defined in software and down loaded at power up and by software commands.
- Provides indication of card status from self-test diagnostics on faceplate Light Emitting Diode (LED).
- Supports loopback of PCM signals to DS30X for diagnostic purposes.
- Card ID provided for auto configuration and determining serial number and firmware level of card.
- Software controlled terminating impedance (600, 900, or 1200 ohm) two and four-wire modes.
- Allows trunk type to be configured on a per port basis in software.
- Software controlled 600 ohm balance impedance is provided.
- Isolation of foreign potentials from transmission and signaling circuit.

**Figure 143**  
**E&M trunk card – block diagram**



553-6201

- Software control of A/μ-Law mode.
- Software control of digit collection.



## Card interfaces

The E&M trunk card passes voice and signaling data over DS-30X loops and maintenance data over the card LAN link.

The E&M trunk card contains four identical and independently configurable trunk interface units (also referred to as circuits). Each unit provides impedance matching and a balance network in a signal transformer/analog hybrid circuit. Also provided are relays for placing outgoing call signaling onto the trunk. Signal detection circuits monitor incoming call signaling. A CODEC performs A/D and D/A conversion of trunk analog voiceband signals to digital PCM signals.

The four units on the card can operate in the A-Law or the  $\mu$ -Law companding mode. The mode is selected by making service change entries. Each unit can be independently configured for 2-wire E&M, 4-wire E&M, and paging trunk types. The trunk type is selected by service change entries and jumper strap settings. All units on the card can perform the following features:

- convert transmission signals from analog-to-digital and digital-to-analog
- provide outpulsing on the card: make/break ratios are defined in software and downloaded at power-up and by software command
- provide 600-ohms balance and termination impedance (2-wire configuration)
- provide 600-ohms termination impedance (4-wire configuration)
- provide pad control for 2-wire and 4-wire facility connections
- enable trunk type and function to be configured on a per-port basis in software
- provide isolation of foreign potentials from transmission and signaling circuit
- provide software control of A-Law and  $\mu$ -Law modes
- support loopback of pulse code modulation (PCM) signals to DS-30X for diagnostic purposes

## Trunk circuit features

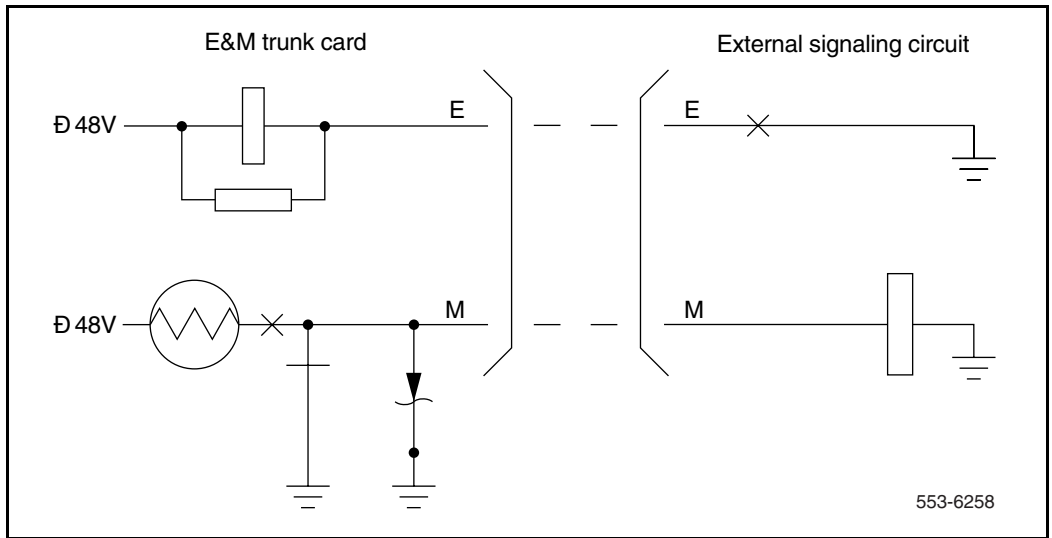
### Trunk unit functions

The functions provided by each unit on the E&M trunk card include 2-wire signaling, 4-wire signaling, and paging operation as follows:

- 2-wire, E&M Type I signaling (see Figure 144 on [page 635](#)) with:
  - near-end seizure and outpulsing with M lead
  - ground detection with E lead
  - voice transmission through tip and ring for transmit and receive
- 4-wire, E&M Type I and II signaling (see Figure 145 on [page 636](#)), 2-way dial repeating with:
  - echo suppression for Type I signaling
  - switchable 7 dB and 16 dB pads for carrier interface
  - voice transmission and reception through two separate paths
  - Type I signaling through E&M leads
  - Type II signaling with near-end seizure by SB/M leads and far-end detection by E/SG lead
- 4-wire, DX signaling (see Figure 146 on [page 637](#))
- paging trunk operation (see Figure 147 on [page 638](#)) with support access by low-resistance path at the PG/A1 leads

**Note:** Paging end-to-end signaling is not supported.

**Figure 144**  
**E&M Type I signaling**



**Figure 145**  
**E&M Type II signaling**

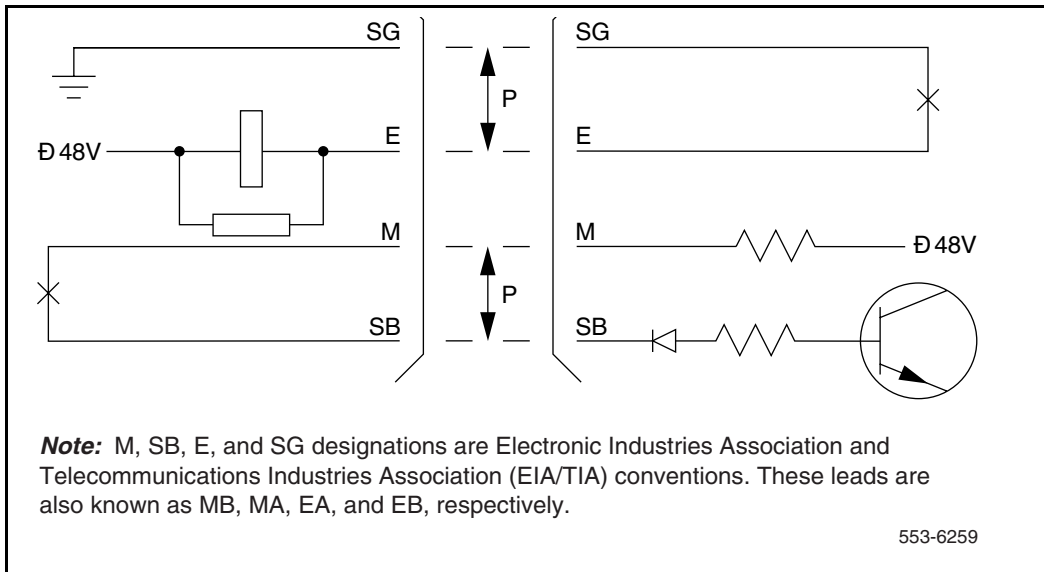
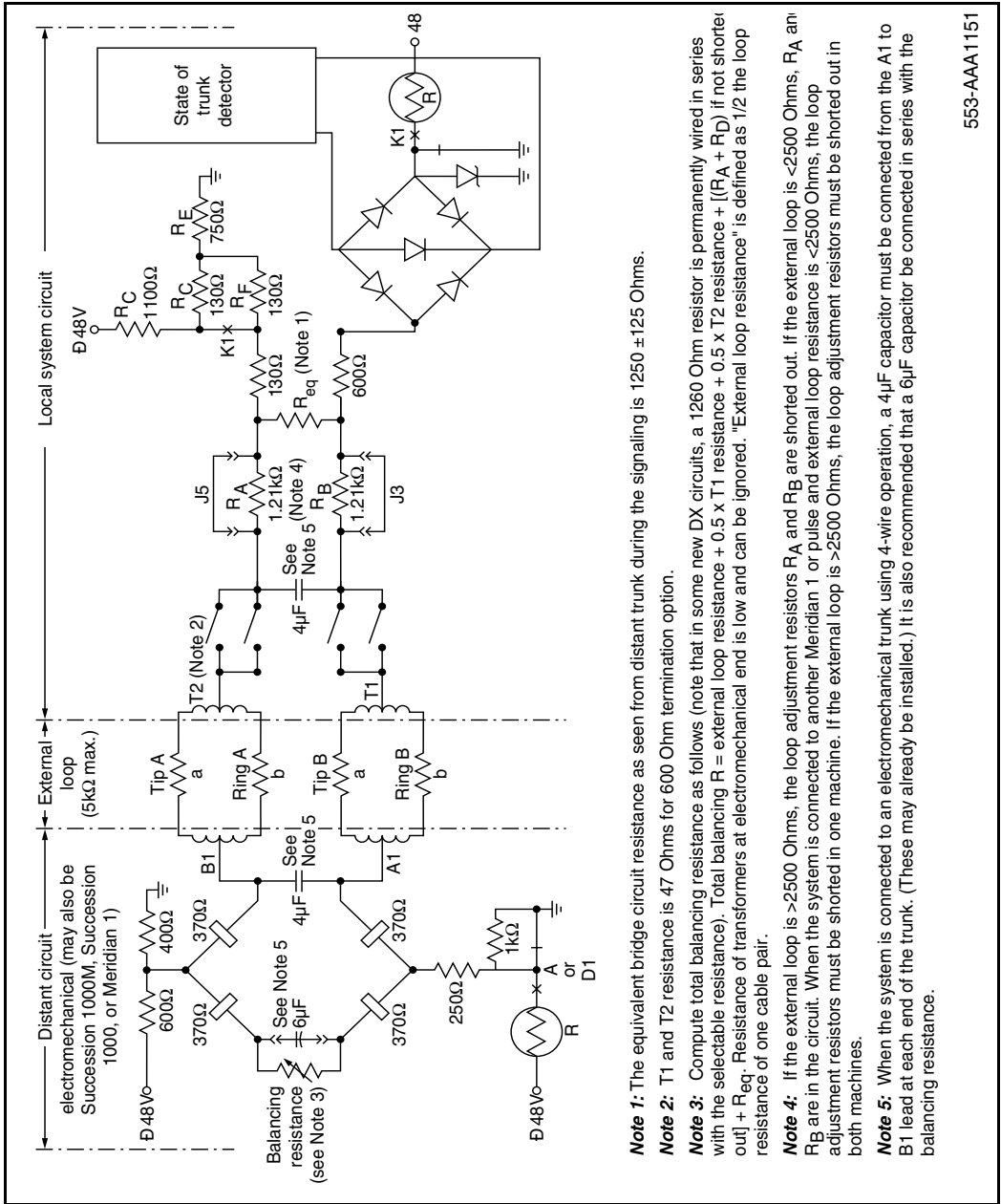
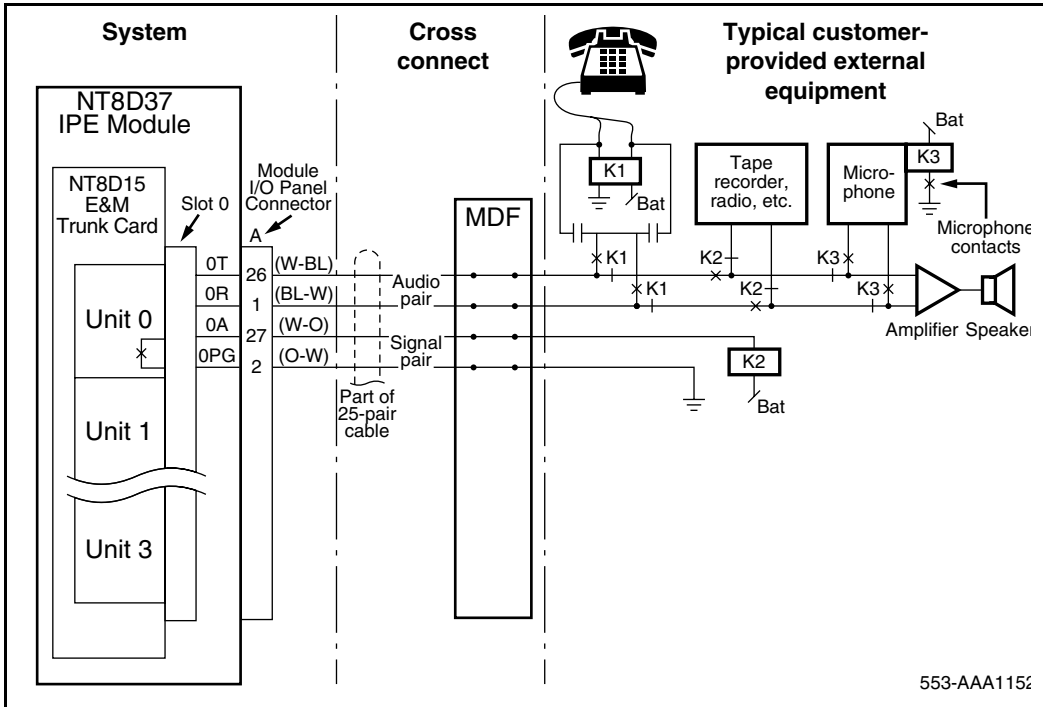


Figure 146  
4-wire DX signaling



553-AAA1151

**Figure 147**  
Paging trunk operation



## **Card control functions**

Control functions are provided by a microcontroller, a card LAN, and signaling and control circuits on the E&M trunk card.

### **Microcontroller**

The E&M trunk card contains a microcontroller that controls the internal operation of the card. The microcontroller provides the following functions:

- card-identification
- self-test
- control of card operation
- maintenance diagnostics

### **Card LAN**

The card LAN provides a serial communication link for transferring maintenance data and control signals between the trunk card and the SSC card. The card LAN controls the microcontroller. The following functions are supported:

- providing card ID/RLS
- reporting self-test status
- polling from the controller card
- enabling/disabling of the DS-30X link

## Signaling interface

All signaling messages for the trunk are three bytes long. The messages are transmitted in channel zero of the DS30X in A10 format.

Configuration information for the E & M trunk is downloaded from the CPU at power up and by command from maintenance programs. Seven configuration messages are sent. One message is sent to each unit (4) to configure trunk type, signaling type, balance impedance etc. Three messages are sent per card to configure the make/break ratio, A/ $\mu$ -Law operation.

### Signaling and control

The signaling and control portion of the E&M trunk card works with the system CPU to operate the card hardware. The card receives messages from the CPU over a signaling channel in the DS-30X loop and returns status information to the CPU over the same channel. The signaling and control portion of the card provides analog loop terminations that establish, supervise, and take down call connections.

Configuration information for the E&M trunk card is downloaded from the CPU at power-up and by command from maintenance programs. Configuration messages are sent. One message is sent to configure trunk and signaling type. The other messages are sent to each card to select the make/break ratio and the A-Law and  $\mu$ -Law modes.

The signaling and control circuits on the card perform the following functions:

- provide an interface between the card and the system CPU
  - transmit PCM signals from each of the four units to one DS-30X timeslot in A10 format (ready to send/clear to send—flow control, handshake format)
  - transmit and receive signaling messages over a DS-30X signaling channel in A10 format
- decode received messages to set configuration and activate/deactivate interface relays for PCM loopback diagnostic purposes
- decode outpulsing messages (one per digit) from the CPU to drive outpulsing relays at 20 pps, 10 pps1 (primary), or 10 pps2 (secondary)



- monitor signals from the trunk interface and generate a message when required for each state change
- control disabling and enabling of unit or card
- control A-Law and  $\mu$ -Law operation modes
- control transmission pad settings

## Maintenance features

The following features are provided for maintenance of the E&M trunk:

- indication of card status from self-test
- software enable and disable capability for individual units or entire card
- loopback of PCM signals to DS-30X for diagnostic purposes
- card ID for autoconfiguration and determination of serial number and firmware level

## Operation

The optional applications, features, and signaling arrangements for each unit on the E&M trunk card are assigned through the Trunk Administration LD 14 and Trunk Route LD 16 programs.

## Signaling and call control

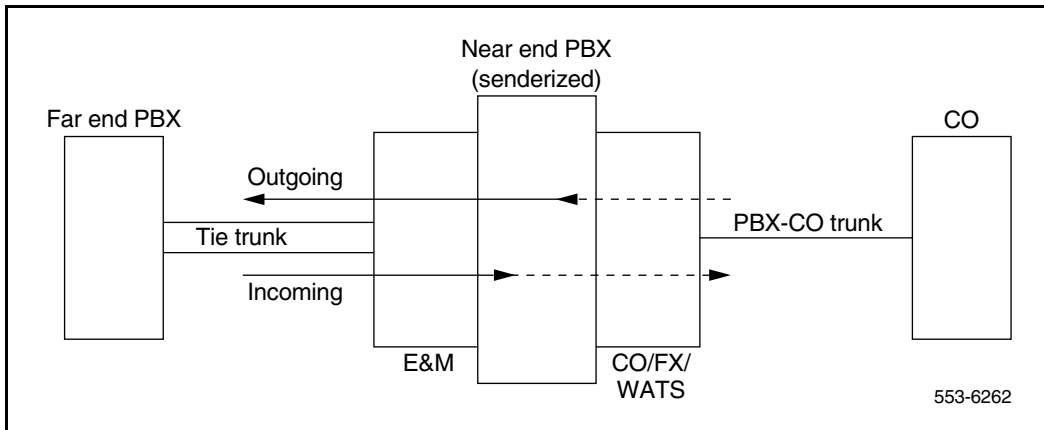
The information in this section describes the signaling and call control of E&M Type I and II trunks. The call is terminated and the trunk released by a disconnect message sent to the associated unit.

Figure 148 on [page 642](#) shows the trunk signaling orientation for a tandem connection between E&M and CO trunks.

### E&M Type I signaling

Figure 149 on [page 643](#) shows E&M Type I signaling patterns for incoming and outgoing calls. Figure 150 on [page 644](#) shows Type I signaling patterns on a tandem connection where the originating end is senderized and the route is over a CO trunk (not applicable to CCSA).

**Figure 148**  
**Signaling orientation for tandem connection between E&M and CO trunks**



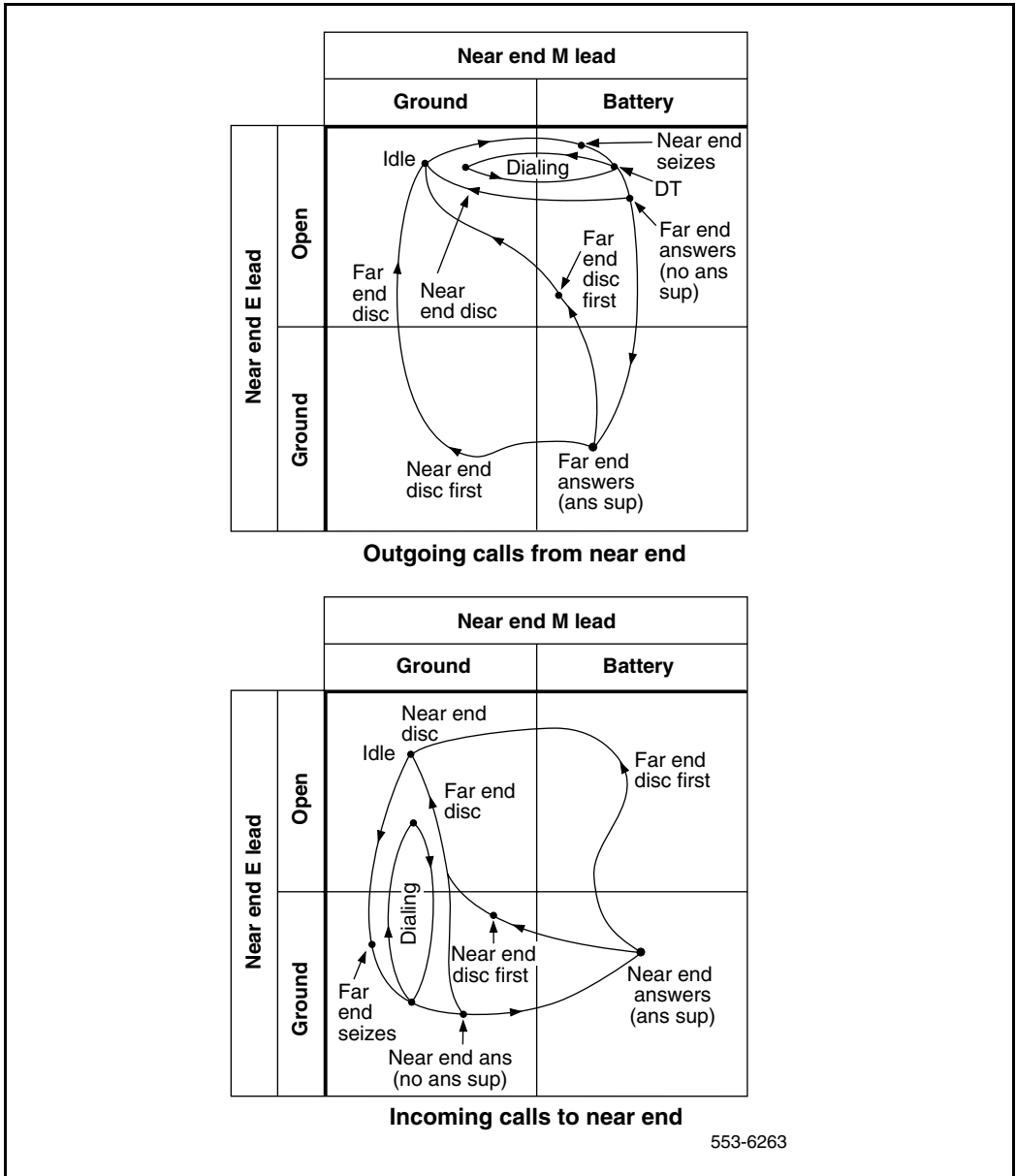
***Idle state***

For E&M signaling, in the idle state the M lead is ground and the E lead is an open circuit.

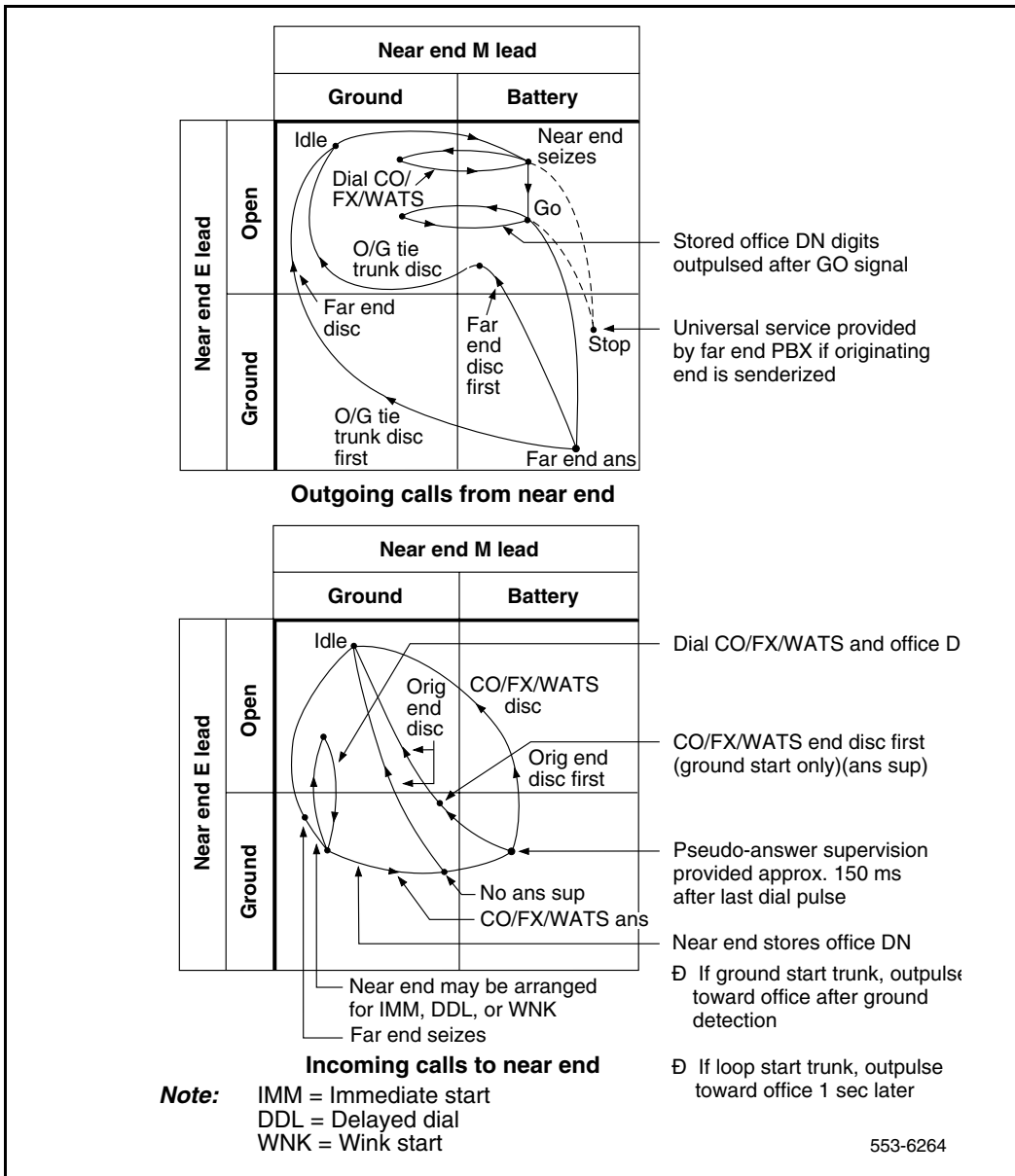
Outgoing calls are processed as follows:

- The M lead changes from ground to battery.
  - If answer supervision is provided by the far end, there is a change from open to ground on the E lead (ground detection).

**Figure 149**  
**E&M Type I signaling patterns – originating party release**



**Figure 150**  
**E&M Type I signaling patterns – originating party release on a tandem connection**



**Incoming calls**

The far-end initiates calls as follows:

- The ground is placed on the E lead in E&M signaling.
- Dial pulses are subsequently applied from the far-end as ground open on the E lead.
- If the far-end is equipped for sending, the system can operate in any mode (immediate start, delay dial, or wink start), as assigned on a start arrangement basis. See Table 197.
  - In immediate start mode, there is no start signal from the called office. The seizure signal (off hook supervisory state) from the far-end should be at least 150 ms. At the end of the seizure signal, the far-end can start pulsing after the standard delay (normally 70 ms minimum).
  - In delay dial mode, a 256–384 ms off hook/on hook signal is returned to the far-end immediately after receipt of the seizure signal. When the far-end detects the on hook signal (start signal), the far-end can start pulsing after the standard delay (normally 70 ms minimum).
  - In wink start mode, within a 128–256 ms period after receipt of the seizure signal from the far-end, the called office transmits a 250 ms, wink start, off hook/on hook signal to the calling office.

**Table 197**  
**Operation Mode**

Operation mode	Start arrangement
Immediate start	IMM
Delay dial	DDL
Wink start	WNK

**E&M Type II signaling**

Figure 151 on [page 647](#) shows E&M Type II signaling patterns for incoming and outgoing calls. Figure 152 on [page 648](#) shows Type II signaling patterns

for a tandem connection where the originating end is senderized and the route is over a CO trunk (CCSA not applicable).

Type II signaling uses four leads: M, SB, E, and SG. Instead of changes of state between battery and ground (M signals) or open and ground (E signals), the trunk signals by closing the contacts between the lead pairs M and SB. Signals are received by detecting current flow between lead pairs E and SG.

On incoming calls, the far end seizes the trunk by shorting the E and SG leads together. This transmits the ground from the SG lead to the E lead (in Type I signaling the ground to the E lead comes from the far-end). Dialing is done by opening and closing the E/SG contacts. Since the SB and M leads are also used as the ESCG and ESC leads, respectively, for echo suppression, echo suppressor control cannot be used with Type II signaling.

*Note:* M, SB, E, and SG designations are Electronic Industries Association and Telecommunications Industries Association (EIA/TIA) conventions. These leads are also known as MB, MA, EA, and EB, respectively.

### **Release control**

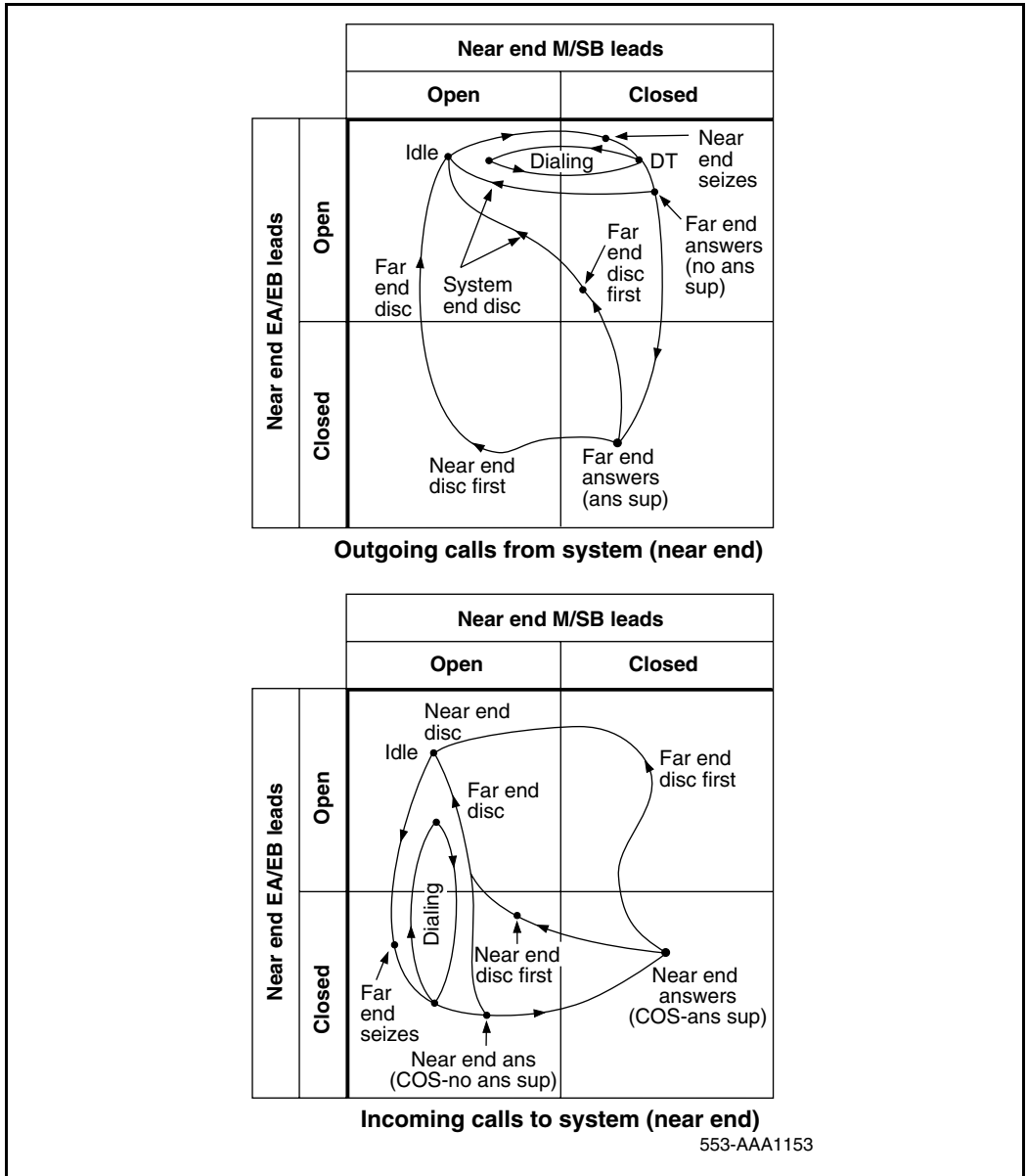
Release control of a call made over a trunk is specified in LD 16. Disconnect supervision is specified for each trunk group independently. The two options available are EITHER or ORIGINATING party control. These can be specified for the end (near-end), or for the central office or other PBX end (far-end). Joint party control can also be specified for the far-end.

### **Duplex signaling**

Duplex (DX) signaling makes use of the voice transmission leads for signaling as well as for voice transmission.

For descriptive purposes, the lead pair Tip B/Ring B is designated the signaling pair. The other pair Tip A/Ring A conducts current in the opposite direction to balance the overall current flow between the near and far ends. During signaling, current flows through both Tip B and Ring B leads in the same direction.

**Figure 151**  
**E&M Type II signaling patterns – originating party release**



**Figure 152**  
**E&M Type II signaling patterns – originating party release on a tandem connection**

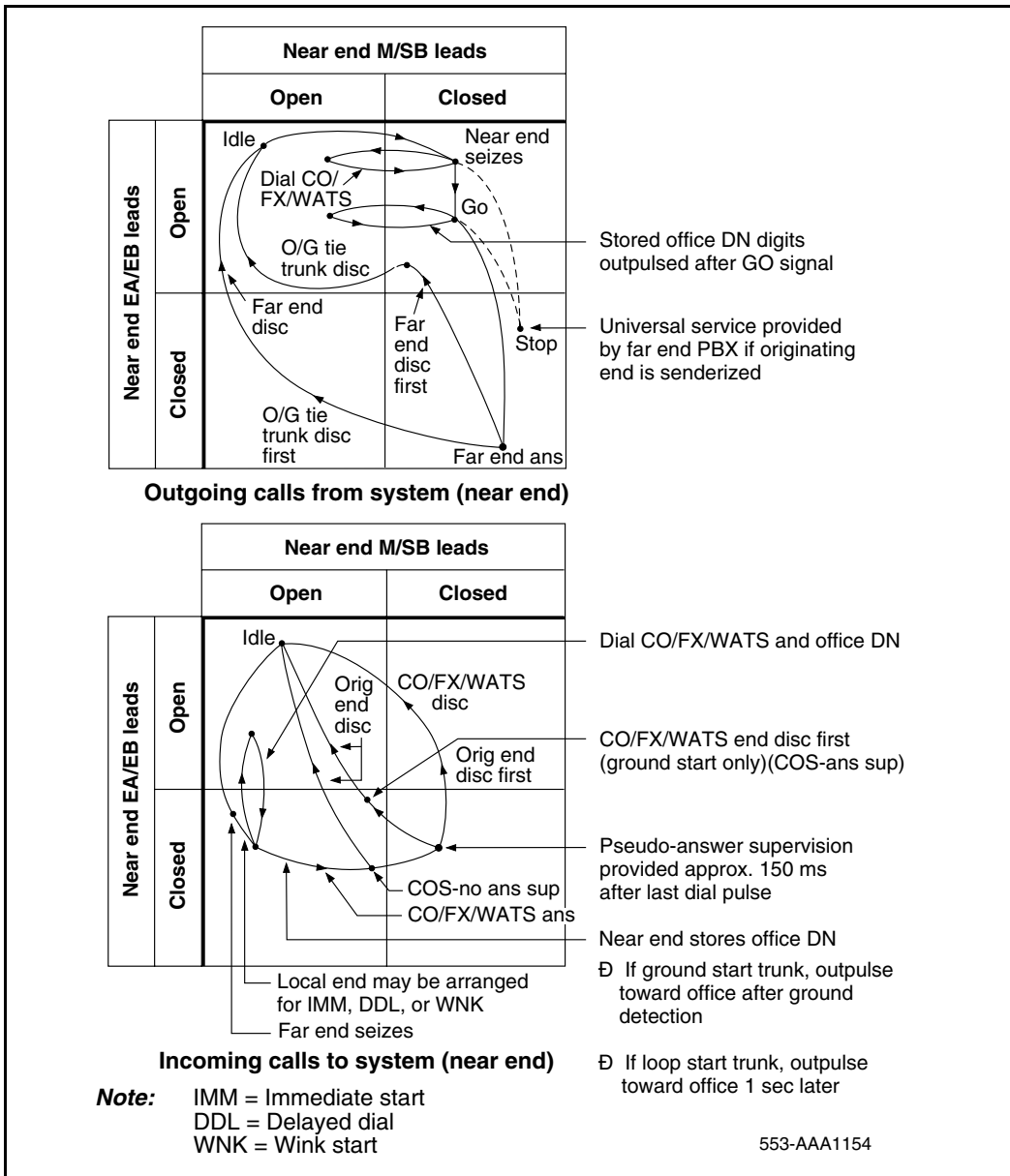




Table 198 and Table 199 show call-connection and take-down sequencing for DX signaling. Table 200 on [page 650](#) and Table 201 on [page 651](#) show sequencing where the E&M trunk card is used in a tandem PBX.

**Table 198**  
**DX signaling – outgoing calls with originating party release**

<b>Condition</b>	<b>Current in signaling lead</b>	<b>State of trunk detector</b>
Idle	No current flow	High
Seizure (dial tone from far-end: far-end ready for digits)	Current flow	High
Digits	Current flow interrupted for each pulse	High
Far-end answers	No current flow	Low
Far-end on hook first	Current flow	High
Network taken down and trunk idled when near-end goes on hook	No current flow	High
Near-end on hook first, network taken down	Current flow	Low
Far-end on hook, trunk idled	No current flow	High

**Table 199**  
**DX signaling – incoming calls with originating party release (Part 1 of 2)**

<b>Condition</b>	<b>Current in signaling lead</b>	<b>State of trunk detector</b>
Idle	No current flow	High
Seizure (dial tone to far-end: near-end ready for digits)	Current flow	Low
Digits	Current flow interrupted for each pulse	Low-high-low for each pulse
Near-end answers	No current flow	Low

**Table 199**  
**DX signaling – incoming calls with originating party release (Part 2 of 2)**

<b>Condition</b>	<b>Current in signaling lead</b>	<b>State of trunk detector</b>
Far-end on hook first	Current flow	High
Network taken down and trunk idled	No current flow	High
Near-end on hook first, network taken down	Current flow	Low
Far-end on hook, trunk idled	No current flow	High

**Table 200**  
**DX signaling – outgoing calls with originating party release on tandem connections (Part 1 of 2)**

<b>Condition</b>	<b>Current in signaling lead</b>	<b>State of trunk detector</b>
Idle	No current flow	High
Seizure (far-end ready for digits)	Current flow	High
Dial CO/FX/WATS	Current flow interrupted for each pulse	High
Stop sender	No current flow	Low
Go sender (universal service provided by far-end PBX if originating end is senderized)	Current flow	High
CO/FX/WATS offices ready for digits		
Stored Office DN digits	Current flow interrupted for each pulse	High
Outpulsed	No current flow	Low
Far end answers	No current flow	Low
Far end on hook first	Current flow	High
Near end on hook, network taken down, trunk idled	No current flow	High

**Table 200**

**DX signaling – outgoing calls with originating party release on tandem connections  
(Part 2 of 2)**

<b>Condition</b>	<b>Current in signaling lead</b>	<b>State of trunk detector</b>
Near end on hook first, network taken down	Current flow	Low
Far end on hook, trunk idled	No current flow	High

**Table 201**

**DX signaling – incoming calls with originating party release on tandem connections  
(Part 1 of 2)**

<b>Condition</b>	<b>Current in signaling lead</b>	<b>State of trunk detector</b>
Idle	No current flow	High
Seizure (Can be arranged for IS, DD, or WS)  (near-end ready for digits)	Current flow	Low
Dial CO/FX/WATS and office DN  Stored digits outputted on CO/FX/WATS trunk after ground detection if a ground start, but after 3 seconds if a loop start	Current flow interrupted for each pulse	Low-high-low for each pulse
If answer supervision: pseudo-answer supervision is sent approximately 13 seconds after last dial pulse received	No current flow	Low

**Table 201**  
**DX signaling – incoming calls with originating party release on tandem connections**  
**(Part 2 of 2)**

Condition	Current in signaling lead	State of trunk detector
If no answer supervision: CO end disconnects (if a CO ground start – the trunk is idled and network taken down, but the incoming TIE trunk is held under control of the originating end)	Current flow	Low
Originating end disconnects – network taken down and trunk idled	No current flow	High

*Note:* \* – CO ground start: the trunk is idled and the network taken down, but the incoming tie trunk is controlled by the originating end.

## Electrical specifications

Table 202 lists the electrical characteristics of the trunk interface on the E&M trunk card.

**Table 202**  
**Electrical characteristics of E&M trunk cards (Part 1 of 2)**

Characteristic	4-wire trunk	2-wire trunk
Signaling range	Type I 150 ohms Type II 300 ohms loop	Type I 150 ohms
Signaling type	Type I, Type II	Type I
Far-end battery	-42 to -52.5 V dc	-42 to -52.5 V dc
Near-end battery	-42.75 to -52.5 V dc	-42.75 to -52.5 V dc
Ground potential difference	±10 V dc	±10 V dc
Line leakage between E lead and ground	Š20K%	Š20K%

**Table 202**  
**Electrical characteristics of E&M trunk cards (Part 2 of 2)**

Characteristic	4-wire trunk	2-wire trunk
Effective loss	See pad table (Table 209 on <a href="#">page 662</a> )	See pad table (Table 209 on <a href="#">page 662</a> )
Terminating impedance	600 ohms	600 ohms
Balance impedance	N/A	600 ohms

**Table 203**  
**Electrical characteristics of trunk cards**

Characteristic	DID Trunk	CO trunk
Nominal impedance	600 or 900 ohms, (selected by software)	600 or 900 ohms, (selected by software)
Signaling range	2450 ohms	1700 ohms
Signaling type	Loop	Ground or loop start
Far-end battery	-42 to -52.5 V	-42 to -52.5 V
Near-end battery	N/A	-42.75 to -52.5 V
Minimum loop current	N/A	20 mA
Ground potential difference	+ 10 V	+ 3 V
Low DC loop resistance during outpulsing	N/A	300 ohms
High DC loop resistance	N/A	Ground start equal to or greater than 30 kS. Loop start equal to or greater than 5 MS
Line leakage	Equal to or greater than 30 kS (Tip to Ring, Tip to GND, Ring to GND).	Equal to or greater than 30 kS (Tip to Ring, Tip to GND, Ring to GND)
Effective loss	See pad table	See pad table

## Power requirements

Table 204 lists the power requirements for the E&M trunk card.

**Table 204**  
**Power requirements**

Voltage	Tolerance	Max current
+15.0 V dc	±5%	200 mA
-15.0 V dc	±5%	200 mA
+8.5 V dc	±2%	200 mA
-48.0 V dc	±5 %	415 mA

## Environmental specifications

Table 205 provides the environmental specifications for the E&M trunk card.

**Table 205**  
**Environmental specifications**

Parameter	Specifications
Operating temperature	0 to +60 degrees C (32 to +140 degrees F), ambient
Operating humidity	5 to 95% RH (non-condensing)
Storage temperature	-40 to +70 degrees C (-40 to +158 degrees F)

## Foreign and surge voltage protection

The E&M trunk card meets CS03 over-voltage (power cross) specifications and FCC Part 68 requirements.

## Connector pin assignments

The E&M trunk card brings the four analog trunks to the backplane through a 160-pin connector shroud. The backplane is cabled to the I/O panel on the rear of the module, which is then connected to the Main Distribution Frame (MDF) by 25-pair cables.

Telephone trunks connect to the E&M trunk card at the MDF using a wiring plan similar to that used for line cards.

A typical connection example is shown in Figure 153 on [page 657](#). A list of the connections to the E&M trunk card in the various 2-wire modes is shown in Table 206. A list of the connections to the E&M trunk card in the various 4-wire modes is shown in Table 207 on [page 656](#).

See the *Communication Server 1000S: Installation and Configuration* (553-3031-210) for complete I/O connector information and wire assignments for each tip/ring pair.

**Table 206**  
**E&M trunk card – backplane pinouts for 2-wire modes**

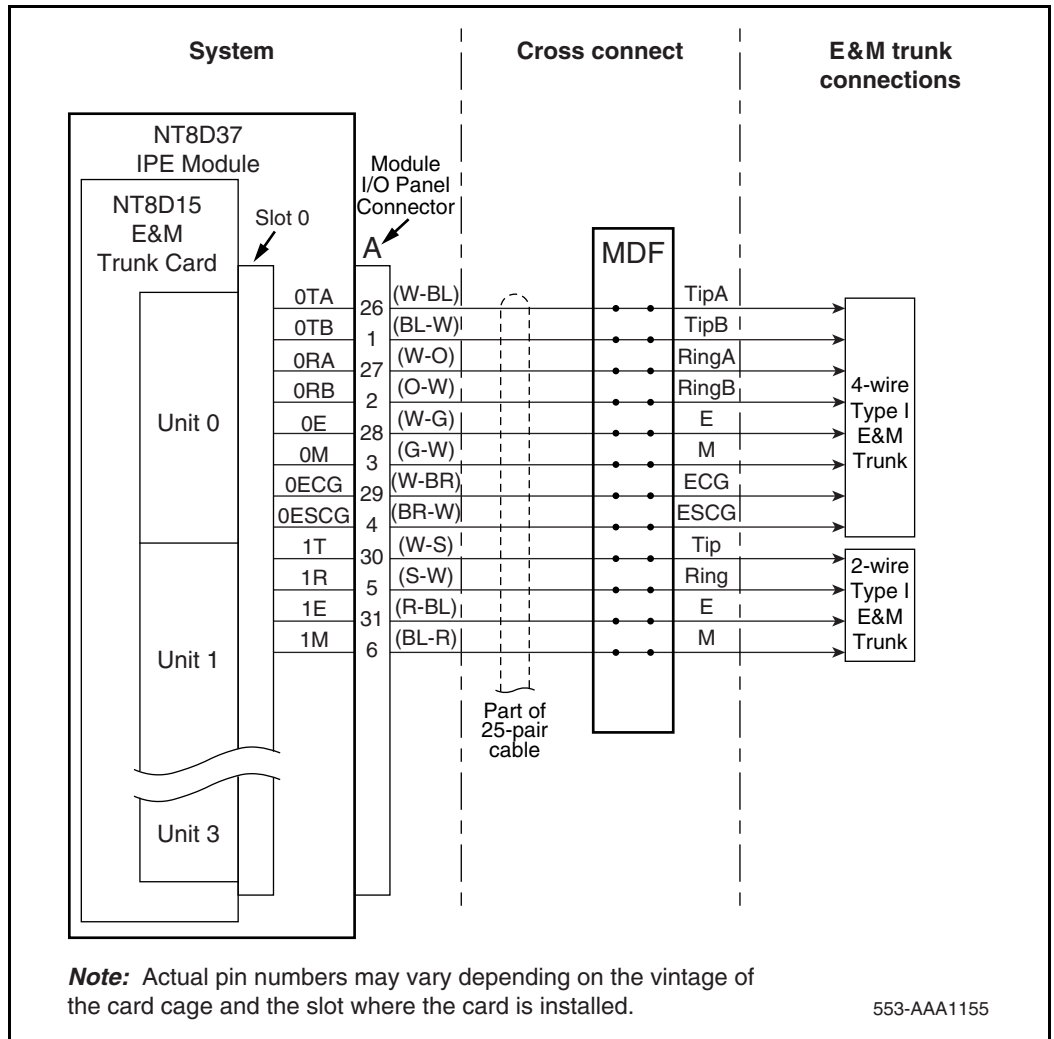
Trunk Number	2-wire Paging Mode				2-wire Type I Mode			
	Pin	Signal	Pin	Signal	Pin	Signal	Pin	Signal
0	12B	Tip	12A	Ring	12B	Tip	12A	Ring
	15B	A	15A	PG	14B	E	14A	M
1	16B	Tip	16A	Ring	16B	Tip	16A	Ring
	19B	A	19A	PG	18B	E	18A	M
2	62B	Tip	62A	Ring	62B	Tip	62A	Ring
	65B	A	65A	PG	64B	E	64A	M
3	66B	Tip	66A	Ring	66B	Tip	66A	Ring
	69B	A	69A	PG	48B	E	68A	M

**Table 207**  
**E&M trunk card – backplane pinouts for 4-wire modes**

Trunk Number	4-wire Type I Mode				4-wire Type II Mode			
	Pin	Signal	Pin	Signal	Pin	Signal	Pin	Signal
0	12B	TA	12A	TB	12B	TA	12A	TB
	13B	RA	13A	RB	13B	RA	13A	RB
	14B	E	14A	M	14B	EA	14A	EB
	15B	ECG	15A	ESCG	15B	MA	15A	MB
1	16B	TA	16A	TB	16B	TA	16A	TB
	17B	RA	17A	RB	17B	RA	17A	RB
	18B	E	18A	M	18B	EA	18A	EB
	19B	ECG	19A	ESCG	19B	MA	19A	MB
2	62B	TA	62A	TB	62B	TA	62A	TB
	63B	RA	63A	RB	63B	RA	63A	RB
	64B	E	64A	M	64B	EA	64A	EB
	65B	ECG	65A	ESCG	65B	MA	65A	MB
3	66B	TA	66A	TB	66B	TA	66A	TB
	67B	RA	67A	RB	67B	RA	67A	RB
	68B	E	68A	M	68B	EA	68A	EB
	69B	ECG	69A	ESCG	69B	MA	69A	MB



**Figure 153**  
**E&M trunk card – typical cross connection example**



## Configuration

Each of the four trunk circuits on the E&M trunk card can be individually configured for trunk type, companding mode, and port-to-port loss compensation. Configuring the card requires both jumper changes and configuration software service entries.

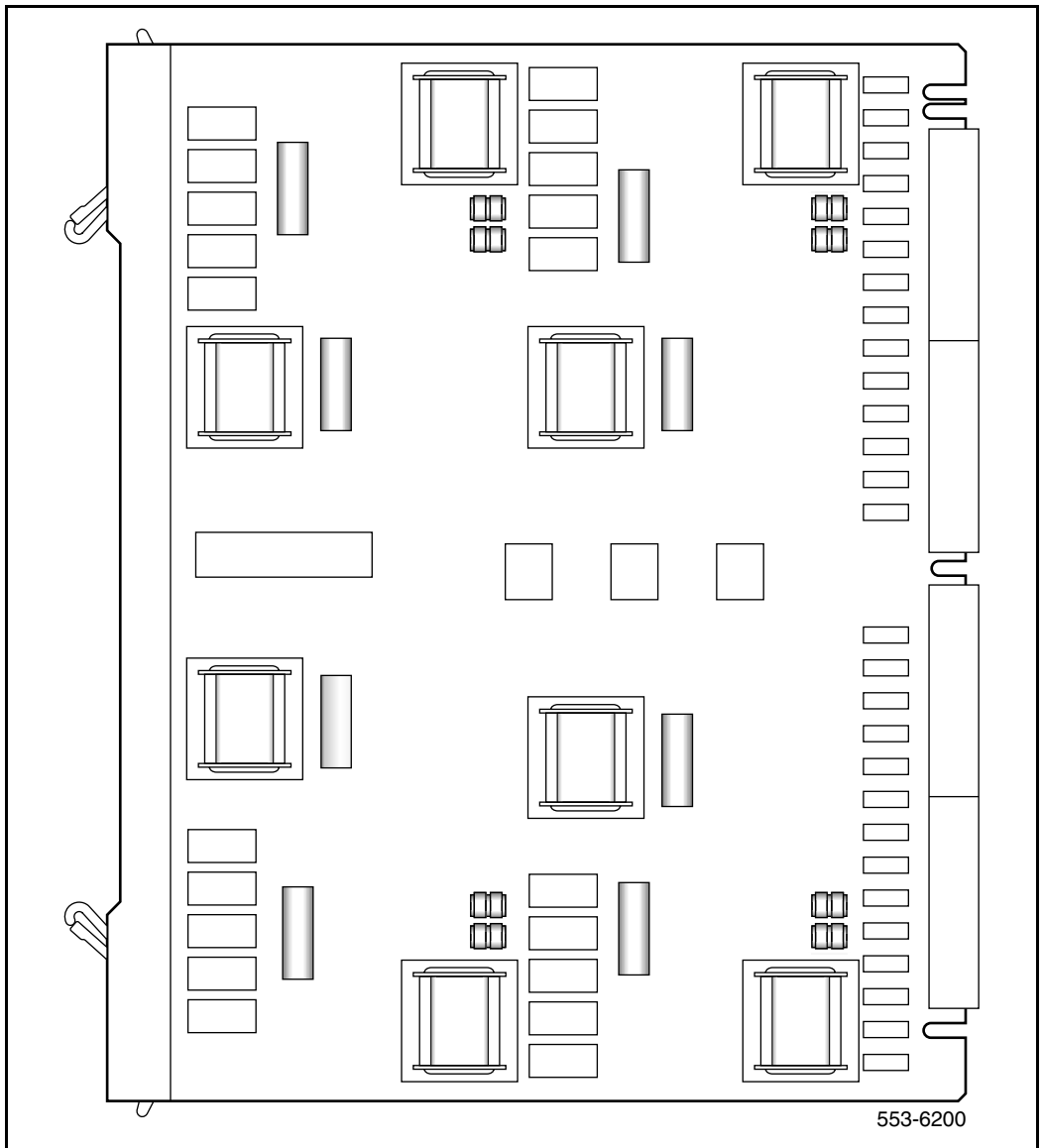
The locations of the jumpers are shown in Figure 154 on [page 659](#).

### Jumper settings

The NT8D15 E&M Trunk card serves various transmission requirements. The four units on the card can operate in A-Law or  $\mu$ -Law companding modes, which are selected by service change entries. Each unit can be independently configured for 2-wire E&M, 4-wire E&M, and paging trunk types. The trunk type is selected by service change entries and jumper strap settings.

See Table 208 on [page 660](#).

Figure 154  
E&M trunk card – jumper locations



**Table 208**  
**E&M trunk card – jumper strap settings**

Jumper (Note 1)	Mode of operation (Note 2)					
	2-wire trunk		4-wire trunk			
	Type I	Paging	Type I	Type II	DX tip & ring pair	
					M—rcv E—xmt	E—rcv M—xmt
J1.X	Off	Off	Off	Off	Pins 1–2	Pins 2–3
J2.X	On	On (Note 3)	On	On	Off	Off
J3.X	Off	Off	Off	Off	(Note 4)	(Note 4)
J4.X	Off	Off	Off	Off	Pins 2–3	Pins 1–2
J5.X	Off	Off	Off	Off	(Note 4)	(Note 4)
J6.X	Off	Off	Off	Off	On	On
J7.X	Off	Off	Off	Off	On	On
J8.X	Off	Off	Off	Off	On	On
J9.X	Pins 2–3	Pins 2–3	Pins 2–3	Pins 2–3	Pins 1–2	Pins 1–2

**Note 1:** Jumper strap settings J1.X through J9.X apply to all four units; “X” indicates the unit number, 0–3.

**Note 2:** “Off” indicates that no jumper strap is installed on a jumper block.

**Note 3:** Paging trunk mode is not zone selectable.

**Note 4:** Jumper strap installed in this location only if external loop resistance is greater than 2500 ohms.

## Software service entries

The trunk type is selected by making service change entries in Route Data Block, Automatic Trunk Maintenance (LD 16). The companding mode is selected by making service change entries in Trunk Data Block (LD 14).

Refer to Table 208 on [page 660](#) to select the proper values for the trunk type being employed.

### Port-to-port loss configuration

Loss parameters are selected on the E&M trunk card by a switchable pad controlled by CODEC emulation software. The pads settings are called “in” and “out.” Pad settings are determined by the three factors listed below (the first two are under direct user control; the third is controlled indirectly):

- Class of Service is assigned in LD 14.
- Facility termination is selected (2-wire or 4-wire) in LD 14 (the 2-wire setting provides 0.5 dB more loss in each direction of transmission for echo control).

*Note:* Facilities associated with the Nortel Electronic Switched Network (ESN) are recommended to be 4-wire for optimum transmission; thus, the 4-wire setting is generally referred to as the ESN setting. However, the 4-wire setting is not restricted to networks using the ESN feature. Conversely, the 2-wire setting, often called non-ESN, can be used on certain trunks in an ESN environment.

- Port-to-port connection loss is automatically set by software on the basis of the port type selected in LD 16; only the port type is set by the user.

The transmission properties of each trunk are characterized by the class of service assigned in LD 14. Transmission properties can be Via Net Loss (VNL) or non-Via Net Loss (non-VNL).

The VNL class of service is assigned at the CLS prompt by typing VNL. The non-VNL class of service is assigned at the CLS prompt by typing TRC (Transmission Compensated) or NTC (Non-Transmission Compensated).

Non-VNL trunks are assigned a TRC or NTC class of service to ensure stability and minimize echo when connecting to long-haul trunks, such as tie

trunks. The class of service determines the operation of the switchable pads contained in each unit. They are assigned as follows:

- TRC for a 2-wire non-VNL trunk facility with a loss of greater than 2 dB, or for which impedance compensation is provided, or for a 4-wire non-VNL facility.
- NTC for a 2-wire, non-VNL trunk facility with a loss of less than 2 dB, or when impedance compensation is not provided.

See Table 209 for the pad switching control for the various through connections and the actual port-to-port loss introduced for connections between the E&M trunk card and any other IPE port designated as Port B.

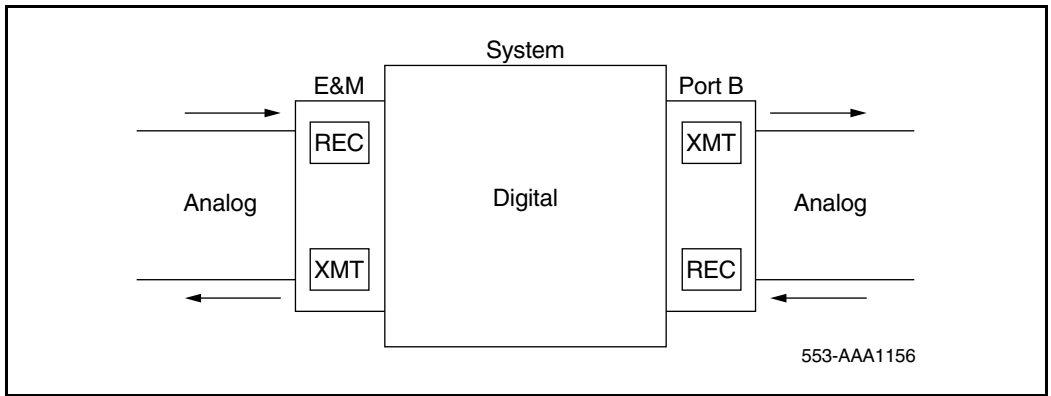
Figure 155 on [page 663](#) shows the pad switching orientation.

**Table 209**  
**Pad switching algorithm**

Port B	Port B pads		E&M Trunk Pads		Port-to-port loss (dB)	
	Transmit D to A	Receive A to D	Transmit D to A	Receive A to D	Port B to E&M	E&M to Port B
IPE line	N/A	N/A	Out	In	2.5	3.5
Universal trunk (TRC)	Out	Out	In	In	0	0
IPE TIE (VNL)	In	Out	In	Out	0	0

**Note:** Transmit and receive designations are from and to the system. Transmit is from the system to the external facility (digital-to-analog direction in the E&M trunk card). Receive is to the system from the external facility (analog-to-digital direction in the E&M trunk card).

Figure 155  
Pad orientation



## Applications

The optional applications, features and signaling arrangements for each trunk are assigned through unique route and trunk data blocks. Refer to the *Features and Services* (553-3001-306) for information about assigning features and services to trunks.

### PAD switching

The transmission properties of each trunk are characterized by class-of-service (COS) assignments in the trunk data block (LD 14). The assignment may be non-Via Net Loss (non-VNL) or via Net Loss (VNL). To ensure stability and minimize echo when connecting to long-haul VNL (Tie) trunks, non-VNL trunks are assigned either Transmission Compensated (TRC) or Non-Transmission Compensated (NTC) class-of-service.

The TRC and NTC COS options determine the operation of the switchable pads contained in the trunk circuits. They are assigned as follows:

- TRC for a two-wire non-VNL trunk facility with a loss of greater than 2 dB or for which impedance compensation is provided, or for a four-wire non-VNL facility.
- NTC for a two-wire non-VNL trunk facility with a loss of less than 2 dB or when impedance compensation is not provided.



Table 210 shows the insertion loss from IPE port to IPE port.

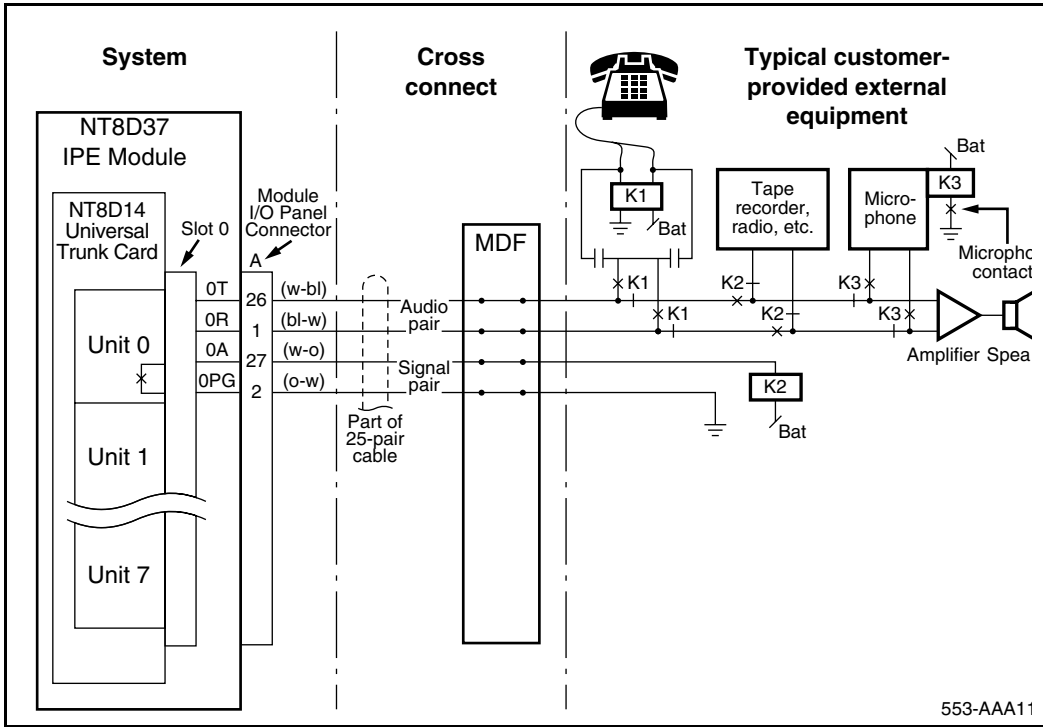
**Table 210**  
**Insertion Loss from IPE Ports to IPE Ports (measured in dB)**

	IPE Ports									
	500/2500 Line		Digital Line		2/4 Wire E&M Trunk		4 Wire (ESN) E&M Trunk		CO/FX /WATS Loop Tie Trunk	
IPE Ports	↓	↑	↓	↑	↓	↑	↓	↑	↓	↑
2/4 Wire E&M Trunk										
→	6		3.5		1					
←	3		-0.5		1					
4 Wire (ESN) E&M Trunk										
→	5.5		3		0.5		0			
←	2.5		-1		0.5		0			

### Paging trunk operation

When used in the paging mode, a trunk is connected to a customer-provided paging amplifier system (not zone selectable). When the trunk is accessed by dial-up or attendant-key operation, it provides a loop closure across control leads PG and A. See Figure 156 on [page 666](#). In a typical application, this transfers the input of the paging amplifier system to the transmission path of the trunk.

**Figure 156**  
**Paging trunk operation**



---

# NT8D41AA Serial Data Interface Paddle Board

---

## Contents

This section contains information on the following topics:

<a href="#">Introduction</a> . . . . .	667
<a href="#">Physical description</a> . . . . .	668
<a href="#">Functional description</a> . . . . .	670
<a href="#">Connector pin assignments</a> . . . . .	671
<a href="#">Configuring the SDI paddle board</a> . . . . .	672
<a href="#">Applications</a> . . . . .	678

## Introduction

The NT8D41AA Serial Data Interface (SDI) paddle board provides two RS-232-C serial ports. These ports allow communication between the system and two external devices. The SDI paddle board is usually used to connect the CS 1000S, CS 1000M, and Meridian 1 system to the system administration and maintenance terminal. It can also be used to connect the system to a background terminal (used in the hotel/motel environment), a modem, or to the Automatic Call Distribution (ACD) or Call Detail Recording (CDR) features.

The SDI paddle board mounts to a special socket on the rear of the backplane of the following modules:

- NT5D21 Core/Network module

- NT6D39 CPU/Network module
- NT9D11 Core/Network module

The SDI paddle board is compatible with all existing system software, but can only be used with the system options listed above. It does not support 20 mA current loop interface.

## Physical description

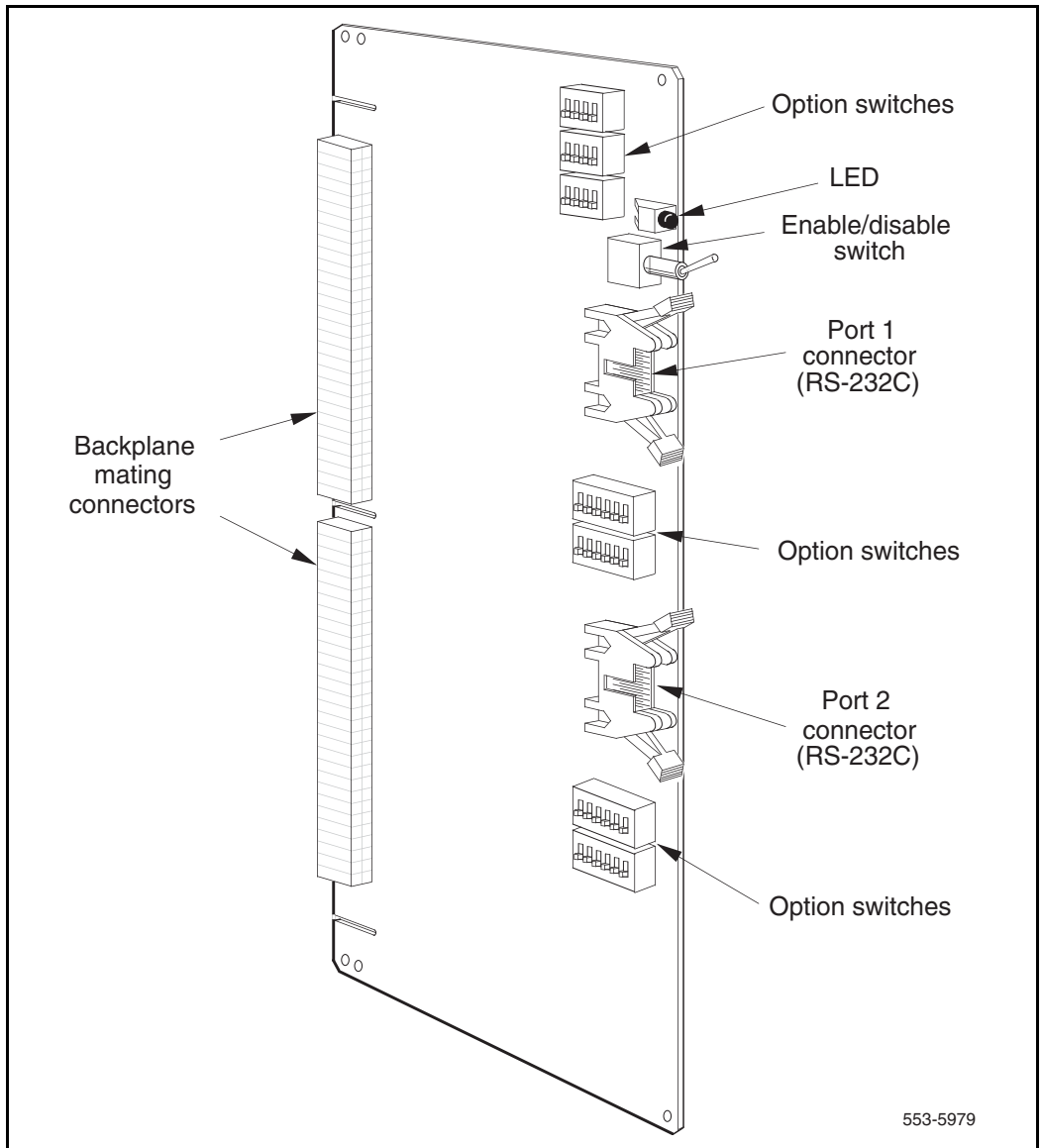
The NT8D41AA Serial Data Interface paddle board is a printed circuit board measuring 31.12 by 12.7 cm (12.25 by 5.0 in.). See Figure 157 on [page 669](#).

Up to two paddle boards can be used in a system backplane for a total of four serial ports. Up to 12 other serial ports can be added by plugging standard serial cards into standard system slots. The two serial ports on each card are addressed as a pair of consecutive addresses (0 and 1, 2 and 3, up to 14 and 15).

The front edge of the card has two serial port connectors, an Enable/Disable switch (ENB/DIS), and a red LED. The LED indicates that the card has been disabled. It is lit when the following occurs:

- the ENB/DIS switch is set to disable
- both ports are disabled in software
- the ports are not configured in the configuration record

Figure 157  
NT8D41AA SDI paddle board

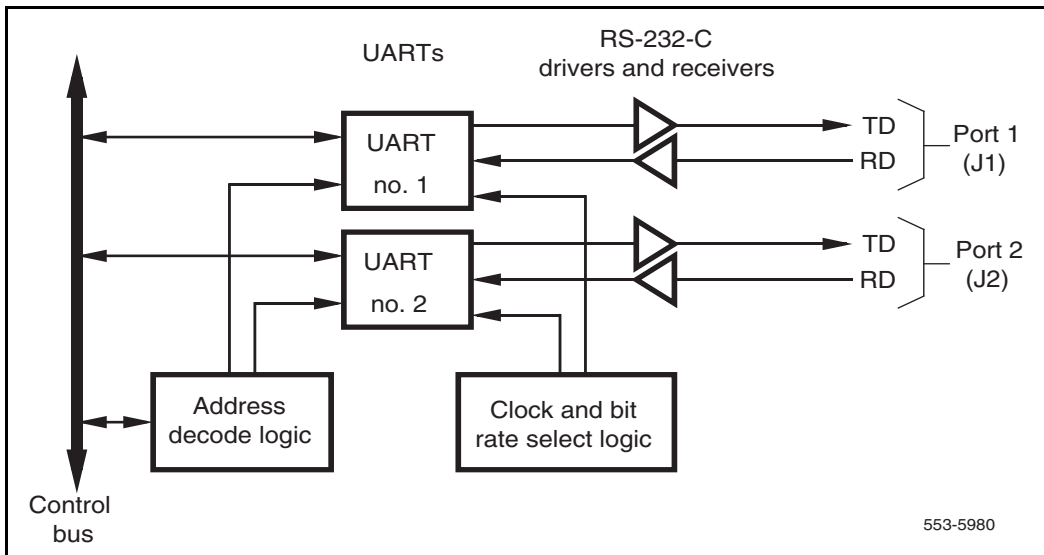


## Functional description

The NT8D41AA SDI paddle board has two asynchronous serial ports. These serial ports are connected to the I/O panel in the back of the shelf using special adapter cables. The serial ports can be used to connect the system to a terminal, a printer, a modem, or to an other system processor.

The SDI paddle board contains two Universal Asynchronous Receiver/Transmitters (UARTs) and the logic necessary to connect the UARTs to the system processor bus. See Figure 158. Other logic on the card includes two baud rate generators, two RS-232-C driver/receiver pairs, and the switches and logic needed to configure the UARTs.

**Figure 158**  
**NT8D41AA SDI paddle board block diagram**



## System considerations

In dual-processor systems, the SDI paddle board will behave differently depending on which backplane socket it is installed in. Installing the paddle board into a socket in the network area of the backplane allows it to work when either of the system processors is active. Installing the paddle board into

a socket in the CPU area of the backplane allows it to work only when that CPU is active.

The SDI paddle board is normally installed into a socket in the network area of the backplane. This allows it to be accessed by either of the system processors. This is necessary because the active CPU switches automatically each night at midnight, and whenever a fault occurs on the active CPU card.

The SDI paddle board can also be installed into a socket in the CPU area of the backplane. This is done when performing maintenance or an upgrade on the system. The SDI paddle board is plugged into the CPU that is not the active system CPU. One of the serial ports on the SDI paddle board is then connected to a maintenance terminal and the CPU board is put into maintenance mode. Diagnostics can then be run from the maintenance terminal without having to stop the system. This is also used to perform a parallel reload of the system software without affecting the operation of the switch.

## Connector pin assignments

The RS-232-C signals for port 1 are brought out on connector J1 and the RS-232-C signals for port 2 are brought out on connector J2. The pinouts of J1 and J2 are identical, so Table 211 can be used for both ports.

**Table 211**  
**Connectors J1 and J2 pin assignments (Part 1 of 2)**

Pin #	Signal	Purpose in DTE mode	Purpose in DCE mode
1	CD	Carrier detect (Note 1)	Carrier detect (Not used)
2	RD	Transmitted data	Received data
3	TD	Received data	Transmitted data
4	DTR	Data terminal ready	Data terminal ready (Note 2)
5	GND	Ground	Ground
6	DSR	Data set ready (Note 1)	Data set ready
7	RTS	Request to send (Not Used)	Request to send (Note 2)

**Table 211**  
**Connectors J1 and J2 pin assignments (Part 2 of 2)**

Pin #	Signal	Purpose in DTE mode	Purpose in DCE mode
8	CTS	Clear to send (Note 1)	Clear to send

**Note 1:** In DTE mode the signals CD, DSR, and CTS are tied to +12 volts to signify that the port on the SDI paddle board is always ready to transmit and receive data.

**Note 2:** In DCE mode the signals DTR and RTS are tied to +12 volts to signify that the port on the SDI paddle board is always ready to transmit and receive data.

## Configuring the SDI paddle board

Configuring the SDI paddle board consists of setting these option switches for each serial port:

- Port address
- Baud rate
- DTE/DCE/Fiber mode

The SDI paddle board has seven option switches, SW 2–8. Figure 159 on [page 676](#) identifies the location of option switches on the SDI paddle board. Instructions for setting these switches are in the section that follows.

Once the board has been installed, the system software must be configured to recognize it. Instructions for doing this are found in “Software service changes” on [page 677](#)”.



## Option switch settings

### Address

Address select switch SW4 and logic on the card always address the two UARTs using a pair of addresses: 0 and 1, 2 and 3 through 15 and 16. The settings for this switch are shown in Table 212.

**Table 212**  
**SDI paddle board address switch settings**

Address		Switch SW4			
Port 1	Port 2	1	2	3	4
0	1	off	on	on	on
2	3	off	on	on	off
4	5	off	on	off	on
6	7	off	on	off	off
8	9	off	off	on	on
10	11	off	off	on	off
12	13	off	off	off	on
14	15	off	off	off	off

### Baud rate

Switches SW2 and SW3 determine the baud rate for each individual port. The settings for these switches are shown in [Table 213 on page 674](#).

**Table 213**  
**SDI paddle board baud rate switch settings**

Baud rate	Port 1 – SW2				Port 2 – SW3			
	1	2	3	4	1	2	3	4
150	off	off	on	on	off	off	on	on
300	off	on	off	on	off	on	off	on
600	off	off	off	on	off	off	off	on
1200	off	on	on	off	off	on	on	off
2400	off	off	on	off	off	off	on	off
4800	off	on	off	off	off	on	off	off
9600	off	off	off	off	off	off	off	off

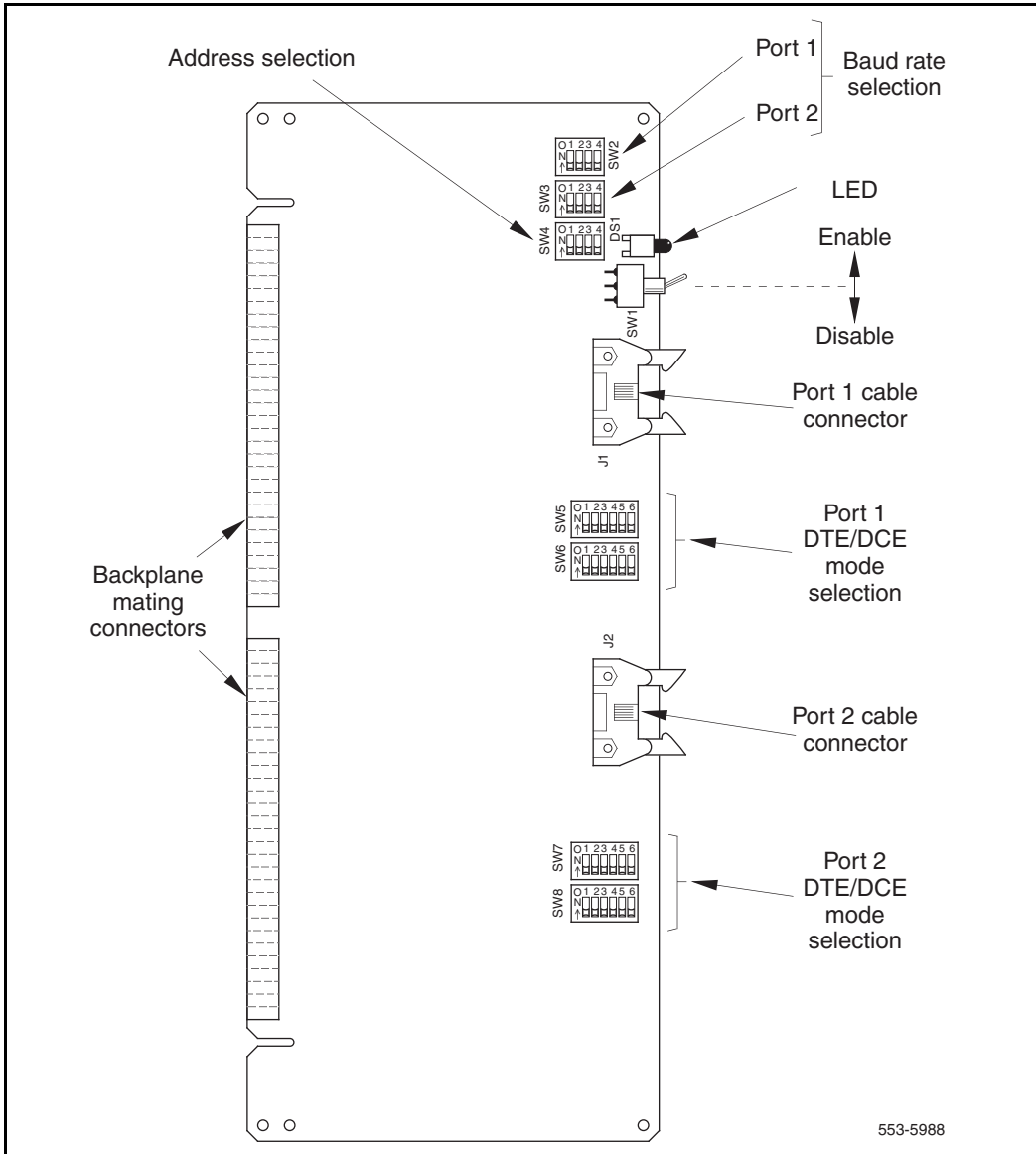
**DTE/DCE/Fiber mode**

Each serial port can be configured to connect to a terminal (DTE equipment), a modem (DCE equipment), or a Fiber Superloop Network card. Instructions for setting the switches SW5, SW6, SW7, and SW8 are shown in Table 214 on [page 675](#).

**Table 214**  
**NT8D41AA DTE/DCE/Fiber switch settings**

Mode	Port 1 – SW5						Port 1 – SW6					
	1	2	3	4	5	6	1	2	3	4	5	6
DTE (terminal)	on	on	on	on	on	on	off	off	off	off	off	off
DCE (modem)	off	off	off	off	off	off	on	on	on	on	on	on
NT1P61 (Fiber)	on	on	on	on	off	off	off	off	on	on	on	on
	Port 2 – SW7						Port 2 – SW8					
DTE (terminal)	on	on	on	on	on	on	off	off	off	off	off	off
DCE (modem)	off	off	off	off	off	off	on	on	on	on	on	on
NT1P61 (Fiber)	on	on	on	on	off	off	off	off	on	on	on	on

Figure 159  
SDI paddle board option switch locations



## Software service changes

Once the NT8D41 SDI paddle board has been installed in the system, the system software needs to be configured to recognize it. This is done using the Configuration Record program LD 17. Instructions for running the Configuration Record program are found in *Software Input/Output: Administration* (553-3001-311).

Some of the prompts that are commonly used when running the Configuration Record program LD 17, are shown in “LD 17 – Serial port configuration parameters.” on [page 677](#). These parameters must be set for each port if both ports are being used.

### LD 17 – Serial port configuration parameters.

Prompt	Response	Description
REQ:	CHG	Change configuration
TYPE:	CFN	Configuration type
IOTB	YES	Change input/output devices
ADAN	NEW TTY x NEW PRT x	Define a new system terminal (printer) port as device x, where x = 0 to 15.
CDNO	1–16	Use the SDI paddle board number to keep track of all ports.
DENS	DDEN	Double density SDI paddle board
USER	xxx	Enter the user of port x. The values that can be entered depend on the software being used. See the <i>Software Input/Output: Administration</i> (553-3001-311) for details.
XSM	(NO) YES	Port is used for the system monitor.

## Applications

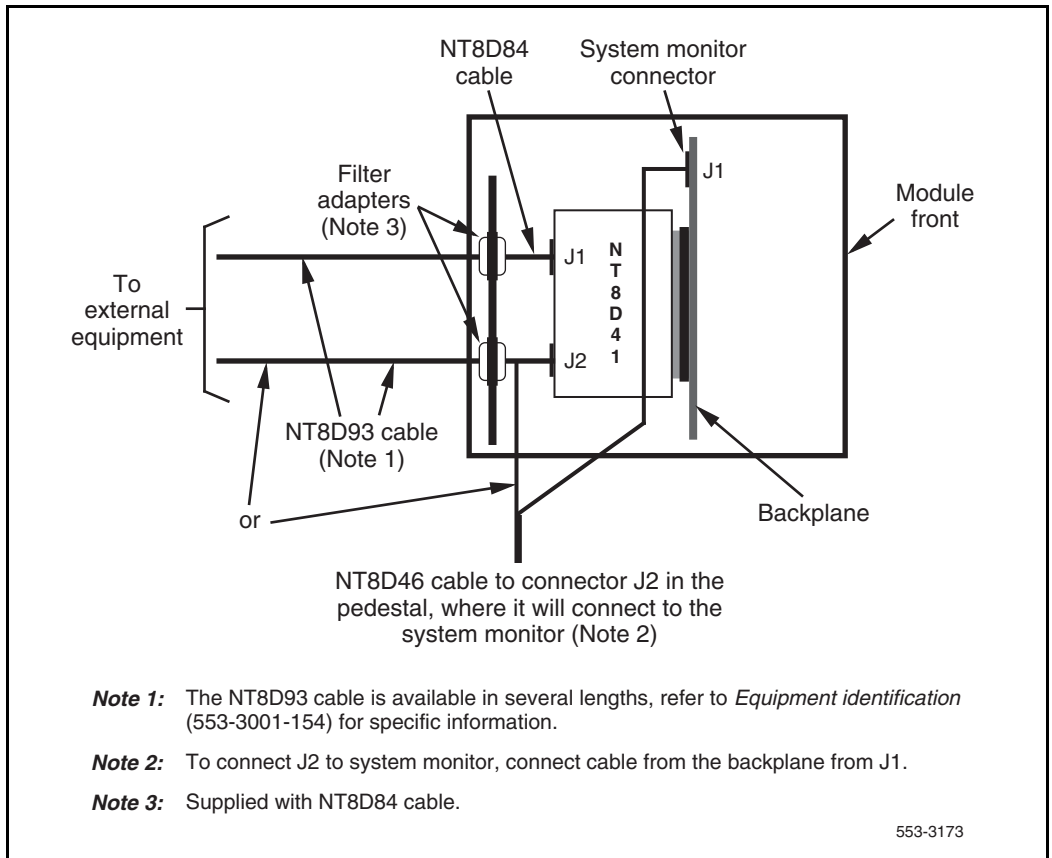
The NT8D41AA Serial Data Interface paddle board is used to connect the switch to a variety of communication devices, printers, and peripherals. Any RS-232-C compatible device can be connected to either of the card's two serial ports.

The standard application for the paddle board is to connect the switch to the system console. This can be either a direct connection if the console is located near the switch, or through a modem for remote maintenance.

Bell 103/212 compatible dumb modems are recommended to connect a remote data terminal. If a smart modem (such as a Hayes modem) is used, configure the modem for the dumb mode of operation (Command Recognition OFF, Command Echo OFF) before connecting the modem to the asynchronous port.

The serial data interface connectors on the paddle board are not RS-232-C standard DB-25 connectors. The NT8D84AA interface cable is used to adapt the paddle board to a non-standard pinout DB-9 connector (normally located on the I/O panel). The NT8D93 cable is then used to connect the non-standard DB-9 connector to a peripheral that uses a RS-232-C standard DB-25 connector. See Figure 160 on [page 679](#).

**Figure 160**  
**SDI paddle board cabling**







---

# NT8D41BA Quad Serial Data Interface Paddle Board

---

## Contents

This section contains information on the following topics:

<a href="#">Introduction</a> . . . . .	681
<a href="#">Physical description</a> . . . . .	682
<a href="#">Functional description</a> . . . . .	682
<a href="#">Connector pin assignments</a> . . . . .	685
<a href="#">Configuring the QSDI paddle board</a> . . . . .	687
<a href="#">Applications</a> . . . . .	692

## Introduction

The NT8D41BA Quad Serial Data Interface (QSDI) paddle board provides four RS-232-C serial ports. These ports allow communication between the system and four external devices, either DTE or DCE. The QSDI paddle board is normally used to connect the system to the system administration and maintenance terminal. It can also be used to connect the system to a background terminal (used in the hotel/motel environment), a modem, or to the Automatic Call Distribution (ACD) or Call Detail Recording (CDR) features.

The QSDI paddle board mounts to a special socket on the rear of the backplane of the following modules:

- NT5D21 Core/Network module

- NT6D39 CPU/Network module
- NT9D11 Core/Network module

The QSDI paddle board is compatible with all existing system software, but can only be used with the system options listed above. It does not support the 110 baud rate or the 20 mA current loop interface.

## Physical description

The NT8D41BA Quad Serial Data Interface paddle board is a printed circuit board measuring 31.12 by 12.7 cm (12.25 by 5.0 in.). See Figure 161 on [page 683](#).

The QSDI paddle board can be used in a system backplane for a total of four serial ports. Up to 12 other serial ports can be added by plugging standard serial cards into standard system slots. The serial ports on the card are addressed as a pair of consecutive addresses (0 and 1, 2 and 3, up to 14 and 15), using switches SW15 and SW16.

The front edge of the card has four serial port connectors, an Enable/Disable switch (ENB/DIS), and a red LED. The LED indicates the card status. It is lit when the following occurs:

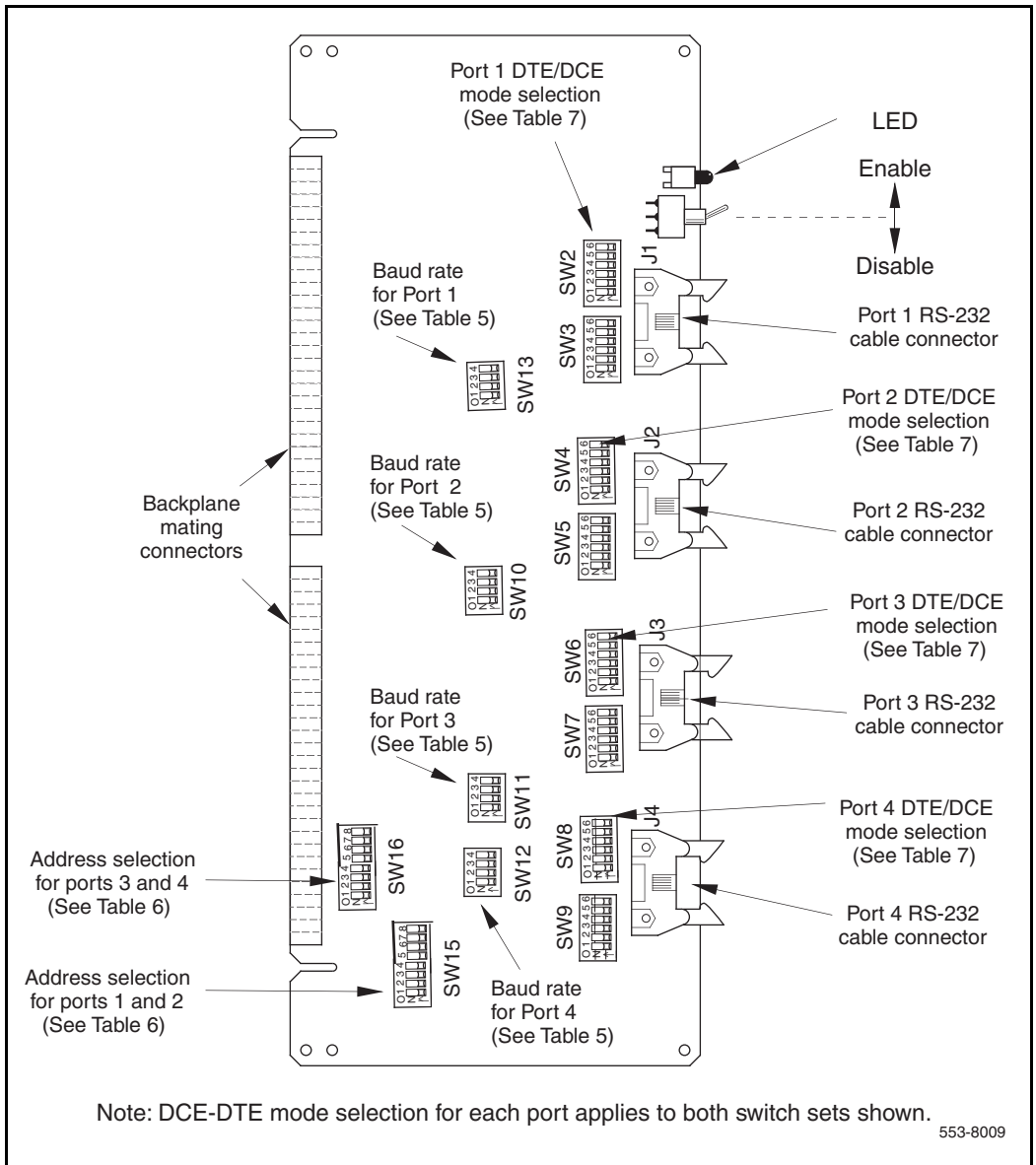
- the ENB/DIS switch is set to disable
- all four ports are disabled in software
- all four ports are not configured in the configuration record

## Functional description

The NT8D41BA QSDI paddle board has four asynchronous serial ports. These serial ports are connected to the I/O panel in the back of the shelf using special adapter cables. The serial ports can be used to connect the system to a terminal, a printer, a modem, or to an other system processor.

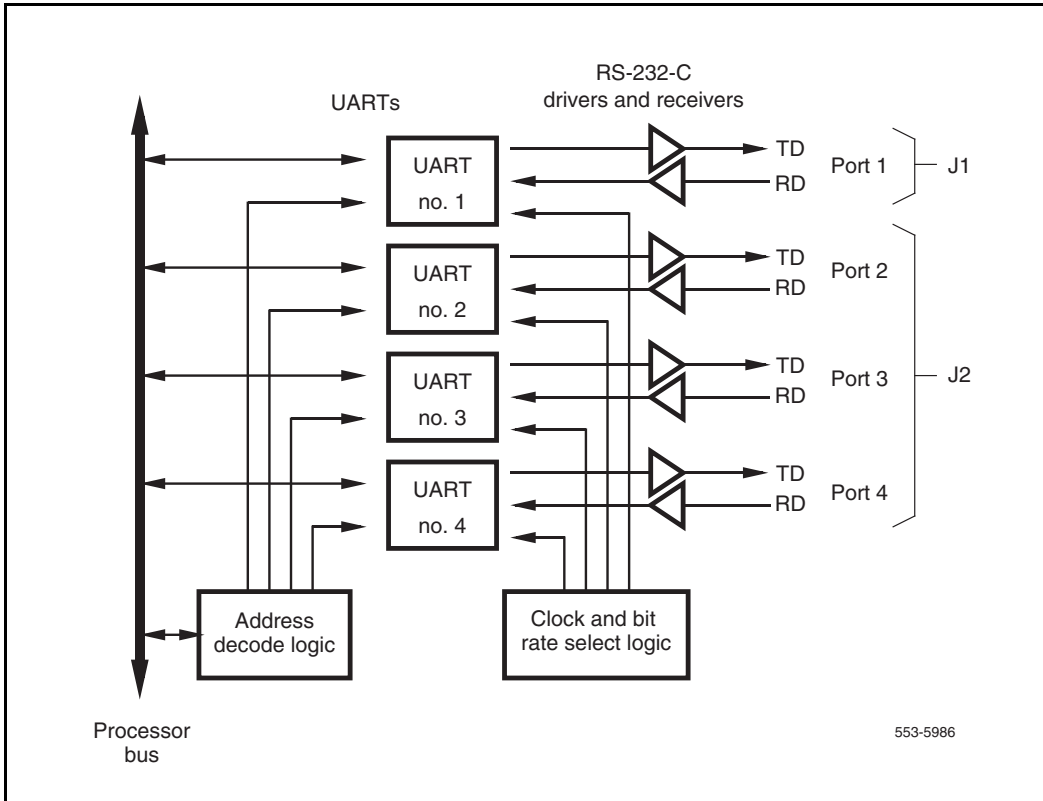
The QSDI paddle board design contains four Universal Asynchronous Receiver/Transmitters (UARTs) and the logic necessary to connect the UARTs to the system processor bus. See Figure 162 on [page 684](#).

**Figure 161**  
**NT8D41BA QSDI paddle board**



Other logic on the card includes baud rate generators, RS-232-C driver/receiver pairs, and the switches and logic needed to configure each UART.

**Figure 162**  
**NT8D41BA QSDI paddle board block diagram**



### System considerations

In dual-processor systems, the QSDI paddle board will behave differently depending on which backplane socket it is installed. Installing the paddle board into a socket in the network area of the backplane allows it to work when either of the system processors is active. Installing the paddle board into a socket in the CPU area of the backplane allows it to work only when that CPU is active.

The QSDI paddle board is normally installed into a socket in the network area of the backplane. This allows it to be accessed by either of the system processors. This is necessary because the active CPU switches automatically each night at midnight and whenever a fault occurs on the active CPU card.

The QSDI paddle board can also be installed into a socket in the CPU area of the backplane (supported in NT6D39AA shelves only). This is done when performing maintenance or an upgrade on the system.

The QSDI paddle board is plugged into the CPU that is not the active system CPU. One of the serial ports on the QSDI paddle board is then connected to a maintenance terminal and the CPU board is put into maintenance mode. Diagnostics can then be run from the maintenance terminal without having to stop the system. This is also used to perform a parallel reload of the system software without affecting the operation of the switch.

## Connector pin assignments

The RS-232-C signals for port 1 through port 4 are brought out on connector J1 through J4 respectively. The pinouts for each port are identical to those for each of the other three ports. Table 215 shows the pin assignment that applies to each connector.

**Table 215**  
**Connectors J1, J2, J3, and J4 pin assignments**

Pin #	Signal	Purpose in DTE mode	Purpose in DCE mode
1	DCD	Data Carrier detect (Note 1)	Data Carrier detect (Not used)
2	RD	Transmitted data	Received data
3	TD	Received data	Transmitted data
4	DTR	Data terminal ready	Data terminal ready (Note 2)
5	GND	Signal Ground	Signal Ground
6	DSR	Data set ready (Note 1)	Data set ready
7	RTS	Request to send (Not Used)	Request to send (Note 2)

**Table 215**  
**Connectors J1, J2, J3, and J4 pin assignments**

Pin #	Signal	Purpose in DTE mode	Purpose in DCE mode
8	CTS	Clear to send (Note 1)	Clear to send

**Note 1:** In DTE mode the signals CD, DSR, and CTS are tied to +12 volts to signify that the port on the QSDI paddle board is always ready to transmit and receive data. This mode is set to connect to a terminal device (DTE).

**Note 2:** In DCE mode the signals DTR and RTS are tied to +12 volts to signify that the port on the QSDI paddle board is always ready to transmit and receive data. This mode is set to connect to a modem device (DCE).

## Configuring the QSDI paddle board

Configuring the QSDI paddle board to work in a system consists of setting these option switches for each serial port:

- Baud rate
- Port address
- DTE/DCE mode

The QSDI paddle board has fourteen option switches, SW2–13, SW15-16. Figure 161 on [page 683](#) identifies the location of option switches on the QSDI paddle board. Learn how to set these switches in the following sections.

Once the board has been installed, the system software must be configured to recognize it. Instructions for doing this are found in the section titled “Software service changes” on [page 691](#).

### Option switch settings

#### Baud rate

Switches SW13, SW10, SW11, and SW12 determine the baud rate for ports 1, 2, 3, and 4, respectively. See the settings for these switches in Table 216.

**Table 216**  
**NT8D41BA baud rate switch settings (Part 1 of 2)**

Baud rate	Baud Clock (kHz)	SW13 (port 1), SW10 (port 2), SW11 (port 3), SW12 (port 4)			
		1	2	3	4
150	2.40	on	off	on	on
300	4.80	on	on	off	on
600	9.60	on	off	off	on
1,200	19.20	on	on	on	off
2,400	38.40	on	off	on	off

**Table 216**  
**NT8D41BA baud rate switch settings (Part 2 of 2)**

Baud rate	Baud Clock (kHz)	SW13 (port 1), SW10 (port 2), SW11 (port 3), SW12 (port 4)			
		1	2	3	4
4,800	76.80	on	on	off	off
9,600	153.60	on	off	off	off
19,200*	307.20	on	on	on	on

\* For future use.

**Address**

Switch SW15 or SW16 and logic on the card always address the four UARTs using a pair of addresses: 0 and 1, 2 and 3 through 14 and 15. The settings for both switches are shown in Table 217. To avoid system problems, switches



SW15 and SW16 must not be configured identically. Figure 161 on [page 683](#) displays SW15 and SW16.

**Table 217**  
**NT8D41BA address switch settings**

SW15	Port 1	Port 2	Switch settings							
SW16	Port 3	Port 4	1*	2 <sup>+</sup>	3	4	5	6	7	8
Device pair addresses	0	1	E	X	off	off	off	off	off	off
	2	3	E	X	off	off	off	off	off	on
	4	5	E	X	off	off	off	off	on	off
	6	7	E	X	off	off	off	off	on	on
	8	9	E	X	off	off	off	on	off	off
	10	11	E	X	off	off	off	on	off	on
	12	13	E	X	off	off	off	on	on	off
	14	15	E	X	off	off	off	on	on	on

\* To enable ports 1 and 2, set SW15 position 1 to ON. To enable ports 3 and 4, set SW16 position 1 to ON.

+ For each X, the setting for this switch makes no difference, because it is not used.

**DTE/DCE/Fiber mode**

Each serial port can be configured to connect to a terminal (DTE equipment), a modem (DCE equipment), or a Fiber Superloop Network card. Instructions for setting the switches SW2, SW3, SW4, SW5, SW6, SW7, SW8, and SW9 are shown in Table 218. Figure 161 on page 683 shows the location of these switches on the paddleboard.

**Table 218**  
**NT8D41BA DTE/DCE/Fiber switch settings**

Mode	Port 1 — SW 3						Port 1 — SW 2					
	1	2	3	4	5	6	1	2	3	4	5	6
DTE (terminal)	on	on	on	off	on	off	off	on	off	on	off	on
DCE (modem)	off	off	off	on	off	on	on	off	on	off	on	off
NT1P61 (Fiber)	on	on	on	on	on	off	on	on	on	off	on	off
	Port 2 — SW 5						Port 2 — SW4					
DTE (terminal)	on	on	on	off	on	off	off	on	off	on	off	on
DCE (modem)	off	off	off	on	off	on	on	off	on	off	on	off
NT1P61 (Fiber)	on	on	on	on	on	off	on	on	on	off	on	off
	Port 3 — SW 7						Port 3 — SW 6					
DTE (terminal)	on	on	on	off	on	off	off	on	off	on	off	on
DCE (modem)	off	off	off	on	off	on	on	off	on	off	on	off
NT1P61 (Fiber)	on	on	on	on	on	off	on	on	on	off	on	off
	Port 4 — SW 9						Port 4 — SW 8					
DTE (terminal)	on	on	on	off	on	off	off	on	off	on	off	on
DCE (modem)	off	off	off	on	off	on	on	off	on	off	on	off
NT1P61 (Fiber)	on	on	on	on	on	off	on	on	on	off	on	off

## Software service changes

Once the NT8D841BA QSDI paddle board has been installed in the system, the system software needs to be configured to recognize it, using the Configuration Record program LD 17. Instructions for running this program are found in *Software Input/Output: Administration* (553-3001-311).

Some of the prompts that are commonly used when running the Configuration Record program LD 17 are shown in LD 17 – Prompts to configure the NT8D841Ba paddle board. These parameters must be set for each port if both ports are being used.

### LD 17 – Prompts to configure the NT8D841Ba paddle board.

Prompt	Response	Description
REQ:	CHG	Change configuration
TYPE:	ADAN	Configuration type
ADAN	NEW TTY x NEW PRT x	Define a new system terminal (printer) port as device x, where x = 0 to 15.
CTYPE	SDI4	Quad port card
DES	XQSDI	Quad density QSDI paddle board.
USER	xxx	Enter the user of port x. The values that can be entered depend on the software being used. See the <i>Software Input/Output: Administration</i> (553-3001-311) for details.
XSM	(NO) YES	Port is used for the system monitor.

## Applications

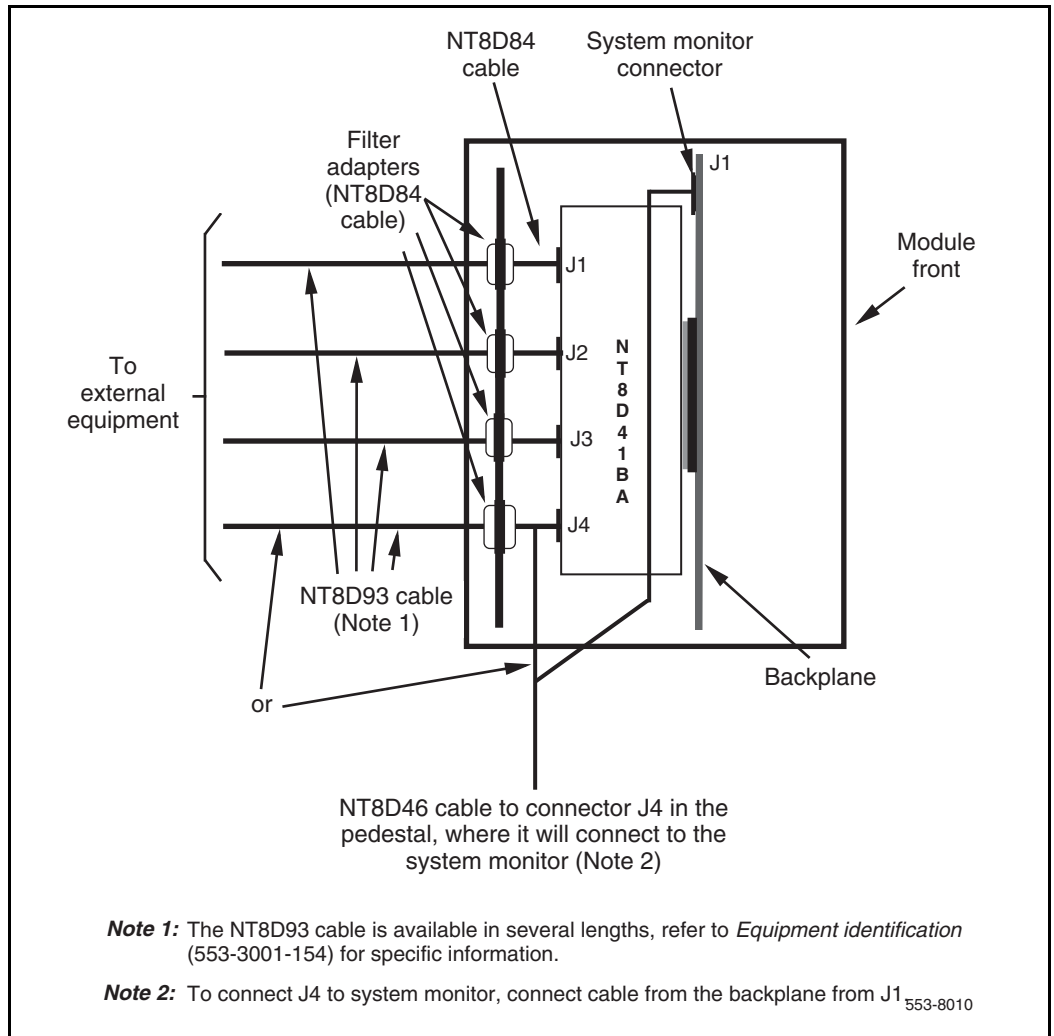
The NT8D41BA Quad Serial Data Interface paddle board is used to connect the switch to a variety of communication devices, printers, and peripherals. Any RS-232-C compatible device can be connected to either of the card's two serial ports.

The standard application for the paddle board is to connect the switch to the system console. This can be either a direct connection if the console is located near the switch, or through a modem for remote maintenance.

Bell 103/212 compatible dumb modems are recommended to connect a remote data terminal. If a smart modem (such as a Hayes modem) is used, configure the modem for the dumb mode of operation (Command Recognition OFF, Command Echo OFF) before connecting the modem to the asynchronous port.

The serial data interface connectors on the paddle board are not RS-232-C standard DB-25 connectors. The NT8D84AA interface cable is used to adapt the paddle board to a non-standard pinout DB-9 connector (normally located on the I/O panel). The NT8D93 cable is then used to connect the non-standard DB-9 connector to a peripheral that uses a RS-232-C standard DB-25 connector. See Figure 163 on [page 693](#).

**Figure 163**  
**NT8D41BA QSDI paddle board cabling**





---

# NTAG26 XMFR card

---

## Contents

This section contains information on the following topics:

<a href="#">Introduction</a> . . . . .	695
<a href="#">MF signaling</a> . . . . .	695
<a href="#">Physical specifications</a> . . . . .	700

## Introduction

The XMFR (Extended Multi-frequency receiver) card is used to receive MF digit information. Connections are made between a PBX and a central office. The XMFR card can only operate in systems using  $\mu$ -law companding.

You can install this card in any IPE slot.

### MF signaling

The MF feature allows the system to receive digits for 911 or feature group D applications.

### Signaling levels

MF signaling uses pairs of frequencies to represent digits.

Table 219 lists the frequency values used for received signals.

**Table 219**  
**MF frequency values**

Digit	Backward direction DOD-Tx, DID-Rx
1	700 Hz + 900 Hz
2	700 HZ + 1100 Hz
3	900 Hz + 1100 Hz
4	700 Hz + 1300 Hz
5	900 Hz + 1300 Hz
6	1100 Hz + 1300 Hz
7	700 Hz + 1500 Hz
8	900 Hz +1500 Hz
9	1100 Hz + 1500 Hz
0	1300 Hz + 1500 Hz
KP	1100 Hz + 1700 Hz
ST	1500 Hz + 1700 Hz
STP(ST')	900 Hz + 1700 Hz
ST2P(ST'')	1300 Hz + 1700 Hz
ST3P(ST''')	700 Hz + 1700 Hz



## XMFR receiver specifications

Table 220 provides the operating requirements for the NTAG26 circuit card.

**Table 220**  
**XMFR receiver specifications (Part 1 of 3)**

<b>Coding:</b>	Mu-Law
<b>Input sensitivity:</b>	must accept: 0 to -25 dBmO must reject: -35 to dBmO
<b>Frequency sensitivity:</b>	must accept: $f \pm (1.5\% + 5\text{Hz})$
<b>Amplitude Twist:</b>	must accept: difference of 6dB between frequencies
<b>Signal Duration:</b>	must accept: > 30 ms must reject: < 10 ms
<b>KP Signal Duration:</b>	must accept: > 55 ms may accept: > 30 ms must reject: < 10 ms
Signal Interruption Bridge:	must ignore: < 10 ms
<b>Time Shift between 2 frequencies:</b> (Envelop for start/stop)	must accept: < 4 ms
Coincidence between 2 frequencies:	must reject: < 10 ms
Intersignal Pause:	must accept: > 25 ms
Maximum Dialling Speed:	must accept: 10 signals per second

**Table 220**  
**XMFR receiver specifications (Part 2 of 3)**

<p>Noise Rejection:  Error Rate in White Noise</p>	<p>Better than: &lt; 1/2500 calls  Test:  10 digit calls  nominal frequency @ -23 dBmO  ON/OFF = 50 ms/50ms  KP duration 100 ms  SNR = -20 dB  all digits</p>
<p>Immunity to Impulse Noise</p>	<p>Better than: &lt; 1/2500 calls  Test:  10 digit calls  nominal frequency @ -23 dBmO  ON/OFF = 50ms/50ms  KP duration 100 ms  SNR = -12 dBs  all digits  ATT Digit Simulation Test, Tape #201 from PUB 56201</p>
<p>Error Rate from Power Lines</p>	<p>Better than: &lt; 1/2500 calls  Test:  10 digit calls  nominal frequency @ -23 dBmO  ON/OFF = 50 ms/50ms  KP duration 100 ms  60 Hz signal @ 81 dBrcn0 (-9dBm)  or  180 Hz signal @ 68 dBrcn0 (-22dBm)  all digits</p>
<p><b>Tolerate Intermodulation:</b></p>	<p>Must tolerate @A-B and @B-A modulation products with a power sum  28 dB below each frequency component level of the signals.</p>

**Table 220**  
**XMFR receiver specifications (Part 3 of 3)**

<p>KP: KP activation</p>	<p>The receiver must not respond to signals prior to KP. Remain unlocked until ST, STP, ST2P or ST3P is received.</p>
<p>Multiple KP's</p>	<p>After the initial KP, subsequent KP's are ignored while in unlocked mode.</p>
<p><b>Excessive Components:</b></p>	<p>If more than two valid frequencies are detected, no digit is reported to the CPU.</p>

The XMFR receiver specifications conform to the following:

- TR-NPL-000258, Compatibility Information for F.G.D. switched access service, Bell Communication Research Technical Reference, Issue 1.0, October 1985.
- TR-NPL-000275, Notes on the BOC Intra-LATA Networks, Bell Communication Research Technical Reference, Chapter 6, 1986.

## Physical specifications

The physical specifications required by the NTAG26 XMFR circuit card are shown in Table 221.

**Table 221**  
**Physical specifications**

Dimensions	Height:12.5 in. (320 mm) Depth:10.0 in. (255 mm) Thickness:7/8 in. (22.25 mm)
Faceplate LED	Lit when the circuit card is disabled
Power requirements	1.1 Amps typical
Environmental considerations	Meets the environment of CS 1000S, CS 1000M, and Meridian 1 systems

---

# NTAK02 SDI/DCH card

---

## Contents

This section contains information on the following topics:

<a href="#">Introduction</a> . . . . .	701
<a href="#">NTAK02 SDI/DCH card</a> . . . . .	701

## Introduction

The NTA02 Serial Data Interface/D-channel (SDI/DCH) digital trunk card is supported in the Media Gateway only for the ISDN Signaling Link (ISL) D-channel. The SDI is not supported in the MG 1000S.

You can install this card in slots 1 through 4 in the MG 1000S. It is not supported in the MG 1000S Expansion. Up to four NTA02 SDI/DCH cards are supported in an MG 1000S.

## NTAK02 SDI/DCH card

The optional SDI/DCH card provides up to four serial I/O ports, which are grouped into two pairs:

- port 0 and port 1
- port 2 and port 3

Ports 1 and 3 are configured as DCH. Ports 0 and 2 are configured as SDI (not supported). See Table 222. Each pair is controlled by a switch, as shown in Table 223.

**Table 222**  
**Port configurations**

Port 0	SDI (not supported)
Port 1	DCH
Port 2	SDI (not supported)
Port 3	DCH

**Table 223**  
**Switch settings**

Port 0	Port 1	SW 1-1	SW 1-2
SDI (not supported)	DCH	OFF	OFF
SDI (not supported)	DCH	OFF	ON
—	ESDI	ON	ON

Port 2	Port 3	SW 1-3	SW 1-4
SDI (not supported)	DCH	OFF	OFF
SDI (not supported)	DCH	OFF	ON
—	ESDI	ON	ON

*Note:* Digital Private Network Signaling System DPNSS can replace the DCH function in the U.K.

Two ports offer the option for DTE/DCE configuration. This option is selected from a jumper on the card. Table 224 shows the jumper settings.

**Table 224**  
**Jumper settings**

Port	Jumper location	Strap for DTE	Strap for DCE	Jumper location	RS422	RS232
0	J10	C - B	B - A			
1	J7 J6	C - B C - B	B - A B - A	J9 J8	C - B C - B	B - A B - A
2	J5	C - B	B - A			
3	J4 J3	C - B C - B	B - A B - A	J2 J1	C - B C - B	B - A B - A

## Connecting to the ports

External devices are connected to the SDI/DCH card by the following:

- the NTAk19FB four-port SDI cable. This cable does not have to be terminated at the cross connect terminal since it is equipped with connectors.
- the NE-A25-B cable. Terminate the NE-A25-B cable at the cross connect terminal. Tables 225 through 228 give the pinouts for the SDI/DCH card.

**Table 225**  
**NTAk02 pinouts – Port 0 at the cross-connect terminal**

Cable		RS232			
		Signal		Designations I=Input O=Output	
Pair	Color	DTE	DCE	DTE	DCE
1T 1R	W-BL BL-W	0 DTR	0 DCD	— O	— I
2T 2R	W-O O-W	DSR DCD	CH/CI DTR	I I	O O
3T 3R	W-G G-W	RTS CTS	CTS RTS	O I	I O
4T 4R	W-BR BR-W	RX TX	TX RX	I O	O I
5T 5R	W-S S-W	— SG	— SG	— —	— —



**Table 226**  
**NTAK02 connections at the cross-connect terminal – Port 1**

Cable		RS422				RS232			
		Signal		Designations I=Input O=Output		Designations I=Input O=Output		Signal	
Pair	Color	DTE	DCE	DTE	DCE	DTE	DCE	DTE	DCE
5T 5R	W-S S-W	SCTEA —	SCTA —	O —	I —	O —	I —	SCT —	SCT —
6T 6R	R-BL BL-R	SCTEB DTR	SCTB DCD	O O	I I	— —	— —	CH/CI DTR	— DCD
7T 7R	R-O O-R	DSR DCD	CH/CI DTR	I I	O O	I I	O O	DSR DCD	CH/CI DTR
8T 8R	R-G G-R	RTS CTS	CTS RTS	O I	I O	O I	I O	RTS CTS	CTS RTS
9T 9R	R-BR BR-R	SCRA SCTA	SCTEA RXCA	I I	O O	I I	O O	SCR SCT	SCT —
10T 10R	R-S S-R	SCRB SCTB	SCTEB RXCB	I I	O O	— —	— —	— —	— —
11T 11R	BK-BL BL-BK	RXDA TXDA	TXDA RXDA	I O	O I	I O	O I	RXD TXD	TXD RXD
12T 12R	BK-O O-BK	RXDB TXDB	TXDB RXDB	I O	O I	— —	— —	— —	— —
25T 25R	V-S S-V	SG —	SG —	— —	— —	— —	— —	SG —	SG —

**Table 227**  
**NTAK02 connections at the cross-connect terminal – Port 2**

Cable		RS422				RS232			
		Signal		Designations I=Input O=Output		Designations I=Input O=Output		Signal	
		Pair	Color	DTE	DCE	DTE	DCE	DTE	DCE
13T	BK-G			—	—	—	—	—	—
13R	G-BK			—	—	O	I	DTR	DCD
14T	BK-BR			—	—	I	O	DSR	CH/CI
14R	BR-BK			—	—	I	O	DCD	DTR
15T	BK-S			—	—	O	I	RTS	CTS
15R	S-BK			—	—	I	O	CTS	RTS
16T	Y-BL			—	—	I	O	RX	TXD
16R	BL-Y			—	—	O	I	TX	RXD
17T	Y-O			O	I	O	I	—	—
17R	O-Y			—	—	—	—	SG	SG

**Table 228**  
**NTAK02 connections at the cross-connect terminal – Port 3**

Cable		RS422				RS232			
		Signal		Designations I=Input O=Output		Designations I=Input O=Output		Signal	
Pair	Color	DTE	DCE	DTE	DCE	DTE	DCE	DTE	DCE
17T 17R	Y-O O-Y	SCTEA —	SCTA —	O —	I —	O —	I —	SCT —	SCT —
18T 18R	Y-G G-Y	SCTEB DTR	SCTB DCD	O O	I I	— —	— —	CH/CI DTR	— DCD
19T 19R	Y-BR BR-Y	DSR DCD	CH/CI DTR	I I	O O	I I	O O	DSR DCD	CH/CI DTR
20T 20R	Y-S S-Y	RTS CTS	CTS RTS	O I	I O	O I	I O	RTS CTS	CTS RTS
21T 21R	V-BL BL-V	SCRA SCTA	SCTEA RXCA	I I	O O	I I	O O	SCR SCT	SCT —
22T 22R	V-O O-V	SCRB SCTB	SCTEB RXCB	I I	O O	— —	— —	— —	— —
23T 23R	V-G G-V	RXDA TXDA	TXDA RXDA	I O	O I	I O	O I	RXD TXD	TXD RXD
24T 24R	V-BR BR-V	RXDB TXDB	TXDB RXDB	I O	O I	— —	— —	— —	— —
25T 25R	V-S S-V	— SG	— SG	— —	— —	— —	— —	SG —	SG —

## Characteristics of the low speed port

Ports 0 and 2 are asynchronous, low speed ports. They transfer data to and from the line one bit at a time.

The characteristics of the low speed port are as follows:

- **Baud rate:** 300; 600; 1200; 2400; 4800; 9600; 19,200  
Default = 1200
- **Parity:** Odd, even, none  
Default = none
- **Stop bits:** 1, 1.5, 2  
Default = 1
- **Flow control:** XON/XOFF, CTS, non.  
Default = none
- **Duplex:** Full
- **Interface:** RS-232-D
- **Data bits:** 5, 6, 7, 8  
Default = 8

## Characteristics of the high speed port

Ports 1 and 3 are synchronous, high speed ports with the following characteristics:

- **Baud rate:** 1200; 2400; 4800; 9600; 19,200; 56,000; 64,000
- **Data bit:** Transparent (1)
- **Duplex:** Full
- **Clock:** Internal or external
- **Interface:** RS-232-D, RS-422-A

---

# NTAK09 1.5 Mb DTI/PRI card

---

## Contents

This section contains information on the following topics:

<a href="#">Introduction</a> . . . . .	709
<a href="#">Physical description</a> . . . . .	710
<a href="#">Functional description</a> . . . . .	714
<a href="#">Architecture</a> . . . . .	715

## Introduction

The NTAk09 1.5 Mb DTI/PRI digital trunk card is a standard-size IPE circuit card.

The NTAk09 provides 1.5Mb ISDN primary rate interface and digital trunk interface capability. The NTAk09 can be equipped with two daughterboards: the NTAk20 clock controller and the NTAk93/NTBK51 D-channel handler interface.

You can install this card in slots 1 through 4 in the MG 1000S. The card is not supported in the MG 1000S Expansion. Up to four digital trunk cards are supported in each MG 1000S.

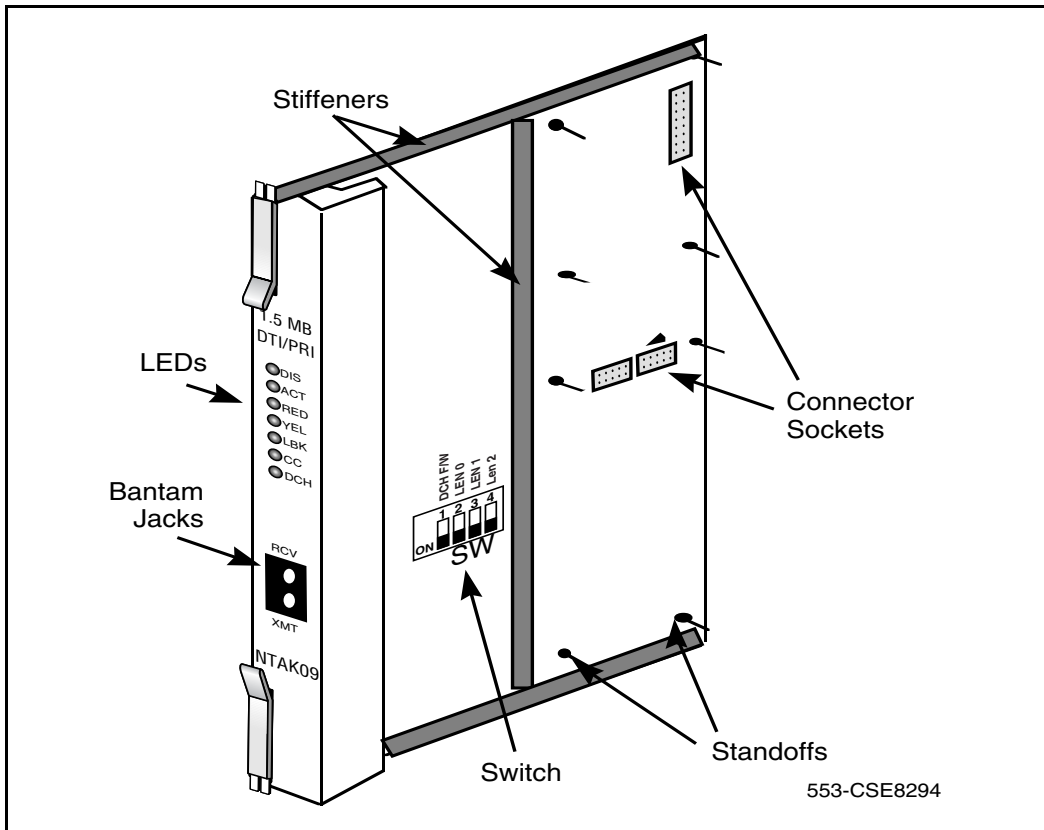
In North America, the NTAk09 can be replaced by the NTRB21 – TMDI (DTI/PRI/DCH) card, which is described in “NTRB21 DTI/PRI/DCH TMDI card” on [page 825](#).

Contact your system supplier or your Nortel representative to verify that this card is supported in your area.

## Physical description

The DTI/PRI card uses a 9.5" by 12.5" multilayer printed circuit board with buried power and ground layers. The clock controller and D-channel daughterboards are fastened by standoffs and connectors. See Figure 164 on [page 710](#).

Figure 164  
NTAK09 DTI/PRI circuit card



The NTAK09 DTI/PRI card has seven faceplate LEDs. The first five LEDs are associated with the NTAK09 card. The remaining two LEDs are associated with the clock controller and DCHI daughterboards.

The first five LEDs operate as follows:

- During system power up, the LEDs are on.
- When the self-test is in progress, the LEDs flash three times and then go into their appropriate states, as shown in Table 229.

**Table 229**  
**NTAK09 LED states**

<b>LED</b>	<b>State</b>	<b>Definition</b>
<b>DIS</b>	On (Red)	The NTAK09 circuit card is disabled.
	Off	The NTAK09 is not in a disabled state.
<b>ACT</b>	On (Green)	The NTAK09 circuit card is in an active state. No alarm states exist, the card is not disabled, nor is it in a loopback state.
	Off	An alarm state or loopback state exists, or the card has been disabled. See the other faceplate LEDs for more information.
<b>RED</b>	On (Red)	A red-alarm state has been detected.
	Off	No red alarm.
<b>YEL</b>	On (Yellow)	A yellow alarm state has been detected.
	Off	No yellow alarm.
<b>LBK</b>	On (Green)	NTAK09 is in loop-back mode.
	Off	NTAK09 is not in loop-back mode.

## NTAK09 DTI/PRI power on self-test

When power is applied to the NTAK09 DTI/PRI circuit card, the card performs a self-test. The LEDs directly associated with the NTAK09 circuit card are DIS, ACT, RED, YEL, and LBK. The clock controller LED is also included in the power on self-test. Table 230 provides the state of the NTAK09 LEDs during the self-test procedure.

**Table 230**  
**NTAK09 LED states during self-test**

Action	LED State
Power up system	Top five LEDs light for eleven seconds
Self-test in progress	<p>Top five LEDs go out for one second</p> <p>If the self-test passes, the top five LEDs flash on and off three times.</p> <p>If the self-test detects a partial failure, the top five LEDs flash on and off five times</p> <p>When the self-test is completed, the LEDs are set to their appropriate states</p>

## NTAK20 power on self-test

The clock controller daughterboard LED is the second LED from the bottom on the faceplate of the NTAK09 DTI/PRI card.

When power is applied to the NTAK20 clock controller, the LED is initially off for two seconds. If the self-test passes, the LED turns red and flashes on and off twice.

When the self-test is completed, the LED remains red until the clock controller is enabled. When enabled, the clock controller LED either turns green or flashes green.



## **NTAK93 self-test**

The NTAK93 DCHI daughterboard LED is the bottom LED on the faceplate of the NTAK09 DTI/PRI card.

The NTAK93 DCHI daughterboard does not perform a self-test when power is applied to it. When power is applied, it turns red and remain steadily lit, indicating the DCH is disabled. When the DCH is enabled, the LED turns green and remains steadily lit.

Self-tests of the NTAK93 daughterboard are invoked manually by commands in LD 96.

## **DTI/PRI local self-test**

The local self-test, also called a local loopback test, checks speech path continuity, zero code suppression, remote alarm detection, and A & B bit signalling. This test is performed manually on a per-loop or per-channel basis. The local loopback test performs a local logical loopback and does not require any external loopback of the T1 signal.

### **Restrictions and limitations**

The DCHI and DTI/PRI must be disabled before performing the self-test on the entire DTI/PRI card. Individual channels must be disabled before performing a self test on a particular channel.

## **Power requirements**

The DTI/PRI obtains its power from the backplane, and draws less than 2 amps on +5 V, 50 mA on +12 V and 50 mA on -12 V.

## **Foreign and surge voltage protection**

Lightning protectors must be installed between an external T1 carrier facility and the system. For public T1 facilities, this protection is provided by the local operating company. In a private T1 facility environment (a campus, for example), the NTAK92 protection assembly can be used.

The NTAk09 circuit card conforms to safety and performance standards for foreign and surge voltage protection in an internal environment.

## Functional description

NTAk09 provides the following features and functions:

- configurable parameters, including A-Law and  $\mu$ -Law operation, digital pads on a per channel basis, and Superframe or Extended Superframe formats
- AMI or B8ZS line coding
- 1.5 Mb Clock recovery and distribution of reference clocks
- DG2 or FDL yellow alarm methods
- card status and alarm indication with faceplate-mounted LEDs
- automatic alarm monitoring and handling
- Card-LAN for maintenance communication
- loopback capabilities for both near-end and far-end
- echo canceler interface
- integrated trunk access (both D-channel and in-band A/B signaling can be mixed on the same PRI)
- faceplate monitor jacks for T1 interface
- configurable D-channel data rate with 64 Kbps, 56 Kbps or 64 Kbps inverted.
- self-test

## Architecture

### Signaling interface

The signaling interface performs an 8 Kbps signaling for all 24 channels and interfaces directly to the DS-30X link. Messages in both directions of transmission are three bytes long.

### Interconnection

The interconnection to the carrier is by NTBK04 1.5 Mb carrier cable.

The NTBK04 is twenty feet long. The NT8D97AX, a fifty-foot extension, is also available.

### Microprocessor

The NTAK09 is equipped with bit-slice microprocessors that handle the following major tasks:

- Task handler: also referred to as an executive, the task handler provides orderly per-channel task execution to maintain real-time task ordering constraints.
- Transmit voice: inserts digital pads, manipulates transmit AB bits for DS1, and provides graceful entry into T-Link data mode when the data module connected to the DTI/PRI trunk is answering the call.
- Receive voice: inserts digital pads and provides graceful entry into T-Link data mode when the data module connected to the DTI/PRI trunk is originating the call.
- T-Link data: a set of transmit and receive vectored subroutines which provides T-Link protocol conversion to/from the DM-DM protocol.
- Receive ABCD filtering: filters and debounces the receive ABCD bits and provides change of state information to the system.
- Diagnostics
- Self-test

## Digital pad

The digital pad is an EPROM whose address-input to data-output transfer function meets the characteristics of a digital attenuator. The digital pad accommodates both  $\mu$ 255-law and A-Law coding. There are 32 combinations each for  $\mu$ 255 to  $\mu$ 255,  $\mu$ 255 to A-Law, A-Law to  $\mu$ 255, and A-Law to A-Law. These values are selected to meet the EIA loss and level plan. See Table 231.

**Table 231**  
**Digital pad values and offset allocations**

Offset	PAD set 0	PAD set 1
0	0dB	-7db
1	2dB	-8db
2	3dB	-9db
3	4dB	-10db
4	5dB	0.6db
5	6.1dB	7db
6	8dB	9db
7	-1dB	10db
8	-3dB	11db
9	-4dB	12db
A	idle code, 7F	3db
B	unassigned code, FF	14db
C	1dB	spare
D	-2dB	spare
E	-5db	spare
F	-6db	spare

## D-channel interface

The D-channel interface is a 64 Kbps maximum, full-duplex, serial bit-stream configured as a DCE device. The data signals include receive data output, transmit data input, receive clock output, and transmit clock output. The receive and transmit clocks can vary slightly from each other as determined by the transmit and receive carrier clocks.

Feature selection through software configuration for the D-channel includes:

- 56 Kbps
- 64 Kbps clear
- 64 Kbps inverted (64 Kbps restricted)

DCHI can be enabled and disabled independent of the PRI card, as long as the PRI card is inserted in its cabinet slot. The D-channel data link cannot be established however, unless the PRI loop is enabled.

On the NTAK09 use switch 1 and position 1 to select either the D-channel feature or the DPNSS feature, as follows:

- OFF = D-channel
- ON = DPNSS (U.K.)

## DS-1 Carrier interface

### Transmitter

The transmitter takes the binary data (dual unipolar) from the PCM transceiver and produces bipolar pulses for transmission to the external digital facility. The DS1 transmit equalizer enables the cabling distance to

extend from the card to the DSX-1 or LD-1. Equalizers are switch selectable through dip-switches. The settings are shown in Table 232.

**Table 232**  
NTAK09 switch settings

Distance to Digital Cross-Connect	Switch Setting			
	1 DCH F/W	2 (LEN 0)	3 (LEN 1)	4 (LEN 2)
0 - 133 feet	Off	Off	Off	On
133 - 266 feet	Off	On	On	Off
266 - 399 feet	Off	Off	On	Off
399 - 533 feet	Off	On	Off	Off
533 - 655 feet	Off	Off	Off	Off

**Receiver**

The receiver extracts data and clock from an incoming data stream and outputs clock and synchronized data. At worst case DSX-1 signal levels, the line receiver will operate correctly with up to 655 feet of ABAM cable between the card and the external DS1 signal source.

**Connector pinout**

The connection to the external digital carrier is through a 15-position male D-type connector. See Table 233.

**Table 233**  
DS-1 line interface pinout for NTBk04 cable (Part 1 of 2)

From 50-pin MDF connector	To DB-15	Signal name	Description
pin 48	pin 1	T	transmit tip to network
pin 23	pin 9	R	transmit ring to network
pin 25	pin 2	FGND	frame ground

**Table 233****DS-1 line interface pinout for NTBK04 cable (Part 2 of 2)**

<b>From 50-pin MDF connector</b>	<b>To DB-15</b>	<b>Signal name</b>	<b>Description</b>
pin 49	pin 3	T1	receive tip from network
pin 24	pin 11	R1	receive ring from network

### **Clock controller interface**

The clock controller interface provides the recovered clock from the external digital facility to the clock controller daughterboard through the backplane. Depending on the equipped state of the clock controller, the clock controller interface enables or disables the appropriate reference clock source, in conjunction with software.

#### **IMPORTANT!**

Each MG 1000S that has a digital trunk **must** have a clock controller clocked to an external reference clock.

*Note:* Clocking slips can occur between MG 1000S systems that are clocked from different Central Offices (COs), if the COs are not synchronized. The slips can degrade voice quality.

### **Clock rate converter**

The 1.5 Mb clock is generated by a Phase-Locked Loop (PLL). The PLL synchronizes the 1.5 Mb DS1 clock to the 2.56 Mb system clock through the common multiple of 8 kHz by using the main frame synchronization signal.





---

# NTAK10 2.0 Mb DTI card

---

## Contents

This section contains information on the following topics:

<a href="#">Introduction</a> . . . . .	721
<a href="#">Physical description</a> . . . . .	722
<a href="#">Functional description</a> . . . . .	723
<a href="#">Architecture</a> . . . . .	724

## Introduction

The NTAk10 2.0 Mb DTI card is a digital trunk card that provides an IPE-compatible 2.0 Mb DTI interface. This circuit card includes an on-board clock controller that can be manually switched in or out of service.

You can install this card in slots 1 through 4 in the MG 1000S. The card is not supported in the MG 1000S Expansion. Up to four digital trunk cards are supported in each MG 1000S.

### **IMPORTANT!**

Each MG 1000S that has a digital trunk **must** have a clock controller clocked to an external reference clock.

*Note:* Clocking slips can occur between MG 1000S systems that are clocked from different Central Offices (COs), if the COs are not synchronized. The slips can degrade voice quality.

## Physical description

The 2 Mb DTI pack uses a standard 9.5" by 12.5", multi-layer printed circuit board. The faceplate is 7/8" wide and contains six LEDs.

The LEDs operate as follows:

- After the card is plugged in, the LEDs (a-e) are turned on by the power-up circuit. The clock controller LED is independently controlled by its own microprocessor.
- After initialization, the LEDs (a-e) flash three times (0.5 seconds on, 0.5 seconds off) and then individual LEDs will go into appropriate states, as shown in Table 234.

**Table 234**  
**NTAK10 LED states (Part 1 of 2)**

LED	State	Definition
<b>DIS</b>	On (Red)	The NTAk10 circuit card is disabled.
	Off	The NTAk10 is not in a disabled state.
<b>OOS</b>	On (Yellow)	The NTAk10 is in an out-of-service state.
	Off	The NTAk10 is not in an out-of-service state.
<b>NEA</b>	On (Yellow)	A near end alarm state has been detected.
	Off	No near end alarm.
<b>FEA</b>	On (Yellow)	A far end alarm state has been detected.
	Off	No far end alarm.
<b>LBK</b>	On (Yellow)	NTAk10 is in loop-back mode.
	Off	NTAk10 is not in loop-back mode.
<b>CC</b>	On (Red)	The clock controller is switched on and disabled.
	On (Green)	The clock controller is switched on and is either locked to a reference or is in free-run mode.

**Table 234**  
**NTAK10 LED states (Part 2 of 2)**

LED	State	Definition
	Flashing (Green)	The clock controller is switched on and locking onto the primary reference.
	Off	The clock controller is switched off.  <b>Note:</b> See “Clock controller interface” on <a href="#">page 729</a> in this chapter for more on tracking and free-run operation.

## Power requirements

The 2MB DTI obtains its power from the backplane. It draws less than 2 A on +5 V, 50 mA on +15 V and 50 mA on –15 V.

## Environment

The NTAk10 card meets all applicable Nortel operating specifications.

## Functional description

The NTAk10 provides the following features and functions:

- a clock controller that can be switched in as an option
- software-selectable A/μlaw operation
- software-selectable digital pads on a per channel basis
- frame alignment and multiframe alignment detection
- frame and multiframe pattern generation
- CRC-4 transmission and reception (software selectable)
- card status and alarm indication with faceplate-mounted LEDs
- Periodic Pulse Metering (PPM) counting
- outpulsing of digits on any of the ABCD bits
- Card-LAN for maintenance communication

- per-channel and all-channel loopback capabilities for near-end and far-end
- self-test
- download of incoming ABCD validation times from software
- warm SYSLOAD (TS16 AS16 transmitted)

### **Applicability to France**

Features specific to DTI requirements for France are implemented in firmware, and are switch-accessed. These are:

- transmission and reception of alarm indication signaling (AIS) in TS16 such as card disabled and warm SYSLOAD
- France-specific PPM counting
- decadic dialing
- France-specific alarm report and error handling

## **Architecture**

The main functional blocks of the NTAk10 card architecture include:

- DS-30X interface
- signaling interface
- three microprocessors
- digital pad
- Card-LAN interface
- carrier interface
- clock controller interface

### **DS-30X interface**

The NTAk10 card interfaces to one DS-30X bus which contains 32 byte-interleaved timeslots operating at 2.56 Mb. Each timeslot contains 10 bits in a 10 message format; eight are assigned to voice/data (64 Kbps), one to signaling (8 Kbps), and one is a data valid bit (8 Kbps).

### **Transmit data**

To transmit data on the carrier, the incoming serial bit stream from the NTAK02 circuit card is converted to 8-bit parallel bytes. The signaling bits are extracted by the signaling interface circuitry.

**Digital Pad:** The parallel data is presented to the pad PROM. The PROM contains pad values, idle code, and A/ $\mu$ -law conversion. They can be set independently for incoming and outgoing voice on a per channel basis. Four conversion formats are provided: A-law to A-law, A-law to  $\mu$ -law,  $\mu$ -law to A-law,  $\mu$ -law to  $\mu$ -law.

Each of these four formats has up to 32 unique pad values. The NTAK10 card provides the pad values of -10, -9, -8, -7, -6, -5, -4, -3, -2, -1, 0, 0.6, 1, 2, 3, 4, 5, 6, 7, 8, 9, 10, 11, 12, 13, and 14 dB (also idle and unassigned code). A negative pad is a positive gain.

The pad PROM output is converted from parallel to serial format and passed on to a multiplexer, which passes PCM/data, TS0, and TS16 information. The FAS pattern is sent in even TS0s, while in odd TS0s alarm information is sent. The multiplexer output is fed to the carrier interface which can forward it to the carrier or perform per channel loopback.

### **Receive data**

To receive data, PCM/Data from the carrier interface is converted from serial to parallel, is buffered, and is fed to the pad prom. It then sent onto the DS-30X interface, where signaling information from the signaling interface circuitry is multiplexed.

### **DS-30X microprocessor**

The DS-30X is a utility processor, responsible for the following tasks:

- controlling the DS-30X interface
- receiving and decoding of messages and taking appropriate action
- transmitting TS16 messages to the TS16 microprocessor
- receiving TS16 messages from the TS16 microprocessor and passing these messages to the A07
- providing the 19.2 Kbps serial interface to the Card-LAN

- controlling LEDs
- downloading Local Calling Areas (LCAs)
- monitoring errors and alarms
- detecting the change of state in TS0, and outputting TS0 data
- counting bipolar violations, slips, PLL alarms, frame-alignment errors, and CRC-4 errors
- monitoring the status of frame alignment and multiframe alignment
- detecting and reporting of alarm indication signals (AIS)
- updating of per channel loopback registers
- controlling the far-end loopback and digroup loopback functions

## Signaling interface

### Interconnections

The external connection is through a 50-pin MDF connector with the NTB05 carrier cable A0394217.

### CEPT interface

For the Conference of European Postal Communications (CEPT) interface, the connection to the external digital carrier is through the NT5K85 DTI cable assembly. It converts the 120 ohms D-connector to 75 ohms coaxial cable. The impedance is switch set. The switch-settings table at the end of this chapter describes the options. See Table 235.

If a coaxial interface is required, use NT5K85 in conjunction with the NTBK05.

**Table 235**  
**2 MB DTI switch options**

<b>Switch</b>	<b>Off (Switch Open)</b>	<b>On (Switch Closed)</b>
S1-1	—	—
S1-2	CC Enabled	CC Disabled
S2-1	120 ohms	75 ohms
S2-2	75 ohms	120 ohms
S3-1	non-French Firmware	French Firmware
S3-2	—	—

### **Channel associated signaling**

Channel associated signaling means that each traffic carrying channel has its own signaling channel permanently associated with it. Timeslot 16 is used to transmit two types of signaling: supervisory and address.

### **Incoming signal**

Functions of the NTAK10 with regard to incoming signaling include:

- recognizing valid changes
- determining which channels made the changes
- collecting PPM
- reporting changes to software

### **Outgoing supervisory signals**

The desired ABCD bit pattern for a channel is output by the NTAK10, under the control of the system controller card. The bit pattern to be transmitted is held on the line for a minimum period of time. This time is specified in the same message and ensures that the signal is detected correctly at the far end.

With the exception of the outpulsing signals and special signals, such as Denmark's Flash signal and Sweden's Parking signal, the minimum duration of any signal state is 100 ms. Some signal states can have a minimum duration time that is longer than 100 ms.

### **Periodic Pulse Metering (PPM)**

Periodic Pulse Monitoring (PPM) is used to collect toll charges on outgoing CO trunk calls.

### **TS16 microprocessor**

The functions of this microprocessor include:

- receiving signaling messages supplied by the DS-30X microprocessor, decoding these messages, and taking subsequent actions
- transmitting messages to the DS-30X microprocessor
- handling PPM
- updating the TS16 select RAM and TS16 data RAM
- providing outpulsing
- receive data from the change-of-state microprocessor
- transmitting AIS for CNET (France) application

### **Change-of-state microprocessor**

The functions of this processor are:

- detecting valid change of state in TS16
- when a valid change has been found, passing the new abcd bits to the TS16 microprocessor, along with five bits to indicate the associated channel

## **Carrier interface**

### **Tx Direction**

The HDB3 encoded multiplexer output is sent to the output selector, which selects the PCM/Data output or the looped around far end data. The HDB3 is



converted from digital to AMI and sent to the carrier. A transformer provides isolation and impedance matching (75 ohms or 120 ohms).

### **Rx Direction**

The AMI data of the carrier is converted to digital and fed to the input selector as well as the output selector for far end loopback. Clock recovery circuitry within the receiving device extracts the 2.0 MHz clock. This clock generates the frame and multiframe count and sends them to the clock controller as a reference.

## **Clock controller interface**

The recovered clock from the external digital facility is provided to the clock controller through the backplane-to-clock controller interface. Depending upon the state of the clock controller (switched on or off), the clock controller interface, in conjunction with software, enables or disables the appropriate reference clock source.

The clock-controller circuitry on NTAK10 is identical to that of the NTAK20. While several DTI/PRI packs can exist in one system, only one clock controller can be activated. All other DTI/PRI clock controllers must be switched off.

### **IMPORTANT!**

Each MG 1000S that has a digital trunk **must** have a clock controller clocked to an external reference clock.

*Note:* Clocking slips can occur between MG 1000S systems that are clocked from different Central Offices (COs), if the COs are not synchronized. The slips can degrade voice quality.

### **Clocking modes**

The clock controller can operate in one of two modes: tracking or non-tracking (also known as free-run).

### ***Tracking mode***

There are two stages to clock controller tracking:

- tracking a reference, and
- locked onto a reference.

When tracking a reference, the clock controller uses an algorithm to match its frequency to the frequency of the incoming clock. When the frequencies are very near to being matched, the clock controller is locked onto the reference. The clock controller will make small adjustments to its own frequency until both the incoming and system frequencies correspond.

If the incoming clock reference is stable, the internal clock controller will track it, lock onto it, and match frequencies exactly. Occasionally, however, environmental circumstances will cause the external or internal clocks to drift. When this happens, the internal clock controller will briefly enter the tracking stage. The green LED will flash momentarily until the clock controller is locked onto the reference once again.

If the incoming reference is unstable, the internal clock controller will continuously be in the tracking stage, with the LED flashing green all the time. This condition does not present a problem, rather, it shows that the clock controller is continually attempting to lock onto the signal. If slips are occurring, however, it means that there is a problem with the clock controller or the incoming line.

### ***Free-run (non-tracking)***

In free-run mode, the clock controller does not synchronize on any source, it provides its own internal clock to the system. This mode can be used when the CS 1000S, Cabinet system are used as a master clock source for other systems in the network. Free-run mode is undesirable if the CS 1000S, Cabinet system are intended to be a slave. It can occur, however, when both the primary and secondary clock sources are lost due to hardware faults or when invoked by using software commands.

## **Clock controller functions and features**

The NTAk10 2MB DTI clock controller functions and features include:

- phase-locking to a reference, generating the 10.24 Mhz system clock, and distributing it to the CPU through the backplane. Up to two references at a time can be accepted.
- providing primary to secondary switchover and auto-recovery
- preventing chatter
- providing error burst detection and correction, holdover, and free running capabilities
- complying with 2.0 Mb CCITT specifications
- communicating with software
- filtering jitter
- making use of an algorithm to aid in detecting crystal aging and to qualify clocking information

## **Reference switchover**

Switchover may occur in the case of reference degradation or reference failure. When performance of the reference degrades to a point where the system clock is no longer allowed to follow the timing signal, then the reference will be said to be out of specification. If the reference being used is out of specification and the other reference is still within specification, an automatic switchover is initiated without software intervention. If both references are out of specification, the clock controller provides holdover.

## **Autorecovery and chatter**

If the software command “track to primary” is given, the clock controller tracks to the primary reference and continuously monitors the quality of both primary and secondary references. If the primary becomes out of specification, the clock controller automatically tracks to secondary provided that it is within specifications. On failure (both out of specification), the clock controller enters the HOLDOVER mode and continuously monitors both references. An automatic switchover is initiated to the reference that recovers first. If the secondary recovers first, then the clock controller tracks to the

secondary, but switches over to the primary whenever the primary recovers. If the primary recovers first, then the clock controller tracks to the primary.

If the software command “track to secondary” is given, the clock controller tracks to the secondary reference and continuously monitors the quality of both primary and secondary references. If the secondary becomes out of specification, the clock controller automatically tracks to primary provided that it is within specifications. On failure (both out of specification), the clock controller enters the HOLDOVER mode and continuously monitors both references. An automatic switchover is initiated to the reference that recovers first. If the primary recovers first, then the clock controller tracks to the primary, but switches over to the secondary whenever the secondary recovers. If the secondary recovers first, then the clock controller tracks to the secondary.

A time-out mechanism prevents chatter due to repeated automatic switching between primary and secondary reference sources.

### **Reference clock selection through software**

The 2MB DTI card has the necessary hardware for routing its reference to the appropriate line on the backplane.

Software is responsible for the distribution of the secondary references and ensures that no contention is present on the REFCLK1 backplane line. Software designates the 2MB DTI card as a primary reference source to the clock controller. The secondary reference is obtained from another 2 Mbps DTI card, which is designated by a craft person. No other clocks originating from other 2MB DTI packs are used.

The clock controller provides an external timing interface and is capable of accepting two signals as timing references. In this case, an external reference refers to an auxiliary timing source which is bridged from a traffic carrying signal. This is not intended to be a dedicated non-traffic bearing timing signal. The clock controller uses either the two external/auxiliary references or the 2MB DTI references.

## Reference clock interface

The recovered clock derived from the facility is available on the MDF connector. The signals at these connectors conform to the electrical characteristics of the EIA RS-422 standard.

## Switch settings

Various 2MB DTI switch options exist on the NTAK10. These are shown in Table 236.

**Table 236**  
**2 MB DTI switch options**

Switch	Off (Switch Open)	On (Switch Closed)
S1-1	—	—
S1-2	CC Enabled	CC Disabled
S2-1	120 ohms	75 ohms
S2-2	75 ohms	120 ohms
S3-1	non-French Firmware	French Firmware
S3-2	—	—

**Note:** The ON position for all the switches is toward the bottom of the card. This is indicated by a white dot printed on the board next to the bottom left corner of each individual switch.



---

# NTAK20 Clock Controller daughterboard

---

## Contents

This section contains information on the following topics:

<a href="#">Introduction</a> . . . . .	735
<a href="#">Physical description</a> . . . . .	738
<a href="#">Functional description</a> . . . . .	739

## Introduction

Digital trunking requires synchronized clocking so that a shift in one clock source results in an equivalent shift in all parts of the network. Synchronization is accomplished with an NTAk20 clock controller daughterboard in each MG 1000S that contains a digital trunk card.

The NTAk20 clock controller daughterboard mounts directly on the following cards:

- NTAk09 1.5Mb DTI/PRI
- NTBk50 2.0 Mb PRI
- NTRB21 DTI/PRI/DCH TMDI
- NTBk22 MISP
- NT6D70 SILC
- NT6D71 UILC

**Note:** The card is restricted to slots 1 through 3 in EMC- type cabinets (such as NAK11Dx and NTAk11Fx cabinets). It will not work in slots 4 through 10 in these cabinets.

The NTAk20 clock controller card can support 1.5 Mb, 2.0 Mb, and 2.56 Mb clock recovery rates.

**IMPORTANT!**

Each MG 1000S that has a digital trunk **must** have a clock controller clocked to an external reference clock.

If an IP Expansion multi-cabinet system is equipped with digital trunk cards, it is mandatory that at least one trunk card is placed in the Main cabinet.

**Note:** Clocking slips can occur between MG 1000S systems that are clocked from different COs, if the COs are not synchronized. The slips can degrade voice quality.

The clock controller circuitry synchronizes the system to an external reference clock and generates and distributes the clock to the system. The system can function either as a slave to an external clock or as a clocking master. The NTAk20AD version of the clock controller meets the AT&T Stratum 3 and Bell Canada Node Category D specifications. The NTAk20BD version meets CCITT Stratum 4 specifications.

The NTAk20 card performs the following functions:

- phase lock to a reference, generation of the 10.24 Mhz system clock, and distribution of the clock to the CPU through the backplane
- accept one primary and one secondary reference
- primary-to-secondary switchover and auto-recovery
- chatter prevention due to repeated switching
- error-burst detection and correction, holdover, and free running capabilities
- communication with software



- jitter filtering
- use of an algorithm to detect crystal aging and qualify clocking information

## Clocking modes

The clock controller can operate in one of two modes: tracking or non-tracking (also known as free-run).

### Tracking mode

In tracking mode, one or more DTI/PRI cards supply a clock reference to the NTAK20 clock controller daughterboard. When operating in tracking mode, one DTI/PRI card is defined as the Primary Reference Source (PREF) for clock synchronization. The other DTI/PRI card is defined as the Secondary Reference Source (SREF). PREF and SREF are defined in LD 73.

There are two stages to clock controller tracking:

- tracking a reference
- locking on to a reference

When tracking a reference, the clock controller uses an algorithm to match its frequency to the frequency of the incoming clock. When the frequencies are almost matched, the clock controller locks on to the reference. The clock controller makes small adjustments to its own frequency until both the incoming and system frequencies correspond.

If the incoming clock reference is stable, the internal clock controller tracks it, locks on to it, and matches frequencies exactly. Occasionally, environmental circumstances cause the external or internal clocks to vary. When this happens, the internal clock controller briefly enters the tracking stage. The green LED flashes until the clock controller is locked on to the reference again.

If the incoming reference is unstable, the internal clock controller continuously tracks, and the LED continuously flashes green. This condition does not present a problem. It shows that the clock controller is continually attempting to lock onto the signal. If slips occur, there is a problem with the clock controller or the incoming line.

### Free-run (non-tracking)

In free-run mode, the clock controller does not synchronize on any outside source. Instead, it provides its own internal clock to the system. This mode can be used when the system acts as a master clock source for other systems in the network. Free-run mode is undesirable if the system is intended to be a slave to an external network clock. Free-run mode can occur when both the primary and secondary clock sources are lost due to hardware faults or invoked using software commands.

## Physical description

### Faceplate LEDs

Each motherboard has five DTI/PRI LEDs and one clock controller LED. The clock controller LED is dual-color (red and green). The clock controller LED states are described in Table 237.

**Table 237**  
**Faceplate LEDs**

State	Definition
On (Red)	NTAK20 is equipped and disabled.
On (Green)	NTAK20 is equipped, enabled, and is either locked to a reference or is in free run mode.
Flashing (Green)	NTAK20 is equipped and is attempting to lock (tracking mode) to a reference. If the LED flashes continuously over an extended period of time, check the CC STAT in LD 60. If the CC is tracking this may be an acceptable state. Check for slips and related clock controller error conditions. If none exist, then this state is acceptable, and the flashing is identifying jitter on the reference.
Off	NTAK20 is not equipped.

## Functional description

The main functional blocks of the NTAK20 architecture include:

- phase difference detector circuit
- digital Phase Locked Loop (PLL)
- clock detection circuit
- digital-to-analog converter
- CPU MUX bus interface
- signal conditioning drivers and buffers
- sanity timer
- microprocessor
- CPU interface
- external timing interface

### Phase difference detector circuit

This circuit, under firmware control, enables a phase difference measurement to be taken between the reference entering the PLL and the system clock.

The phase difference is used for making frequency measurements and evaluating input jitter and PLL performance.

### Digital phase lock loops

The main digital PLL enables the clock controller to provide a system clock to the CPU. This clock is both phase and frequency locked to a known incoming reference.

The hardware has a locking range of  $\pm 4.6$  ppm for Stratum 3 and  $\pm 50$  ppm for Stratum 4 (CCITT).

A second PLL on the clock controller provides the means for monitoring another reference. Note that the error signal of this PLL is routed to the phase difference detector circuit so the microprocessor can process it.

### System clock specification and characteristics

Since the accuracy requirements for CCITT and EIA Stratum 3 are different, it is necessary to have two TCVCXOs which feature different values of frequency tuning sensitivity. See Table 238.

**Table 238**  
**System clock specification and characteristics**

Specifications	CCITT	EIA
Base Frequency	20.48 MHz	20.48 MHz
Accuracy	$\pm 3$ ppm	$\pm 1$ ppm
Operating Temperature	0 to 70 C $\pm 1$ ppm	0 to 70 C $\pm 1$ ppm
Drift Rate (Aging)	$\pm 1$ ppm per year	$\pm 4$ ppm in 20 years
Tuning Range (minimum)	$\pm 60$ ppm min. $\pm 90$ ppm max.	$\pm 10$ ppm min. $\pm 15$ ppm max.
Input Voltage Range	0 to 10 volts, 5V center	0 to 10 volts, 5V center

### EIA/CCITT compliance

The clock controller complies with 1.5 Mb EIA Stratum 3ND, 2.0 Mb CCITT or 2.56 Mb basic rate. The differences between these requirements mainly affect PLL pull in range. Stratum 4 conforms to international markets (2.0 Mb) while Stratum 3 conforms to North American markets (1.5 Mb).

### Monitoring references

The primary and secondary synchronization references are continuously monitored in order to provide autorecovery.

### Reference switchover

Switchover occurs in the case of reference degradation or loss of signal. When performance of the reference degrades to a point where the system clock is no longer allowed to follow the timing signal, then the reference is out of specification. If the reference is out of specification and the other reference is still within specification, an automatic switchover is initiated

without software intervention. If both references are out of specification, the clock controller provides holdover.

### **Autorecovery and chatter**

If the command “track to primary” is given, the clock controller tracks to the primary reference and continuously monitors the quality of both primary and secondary references. If the primary goes out of specification, the clock controller will automatically “track to secondary” if the secondary is within specifications. On failure (both out of specification), the clock controller enters the HOLDOVER mode and continuously monitors both references. An automatic switchover is initiated to the reference that recovers first. If the secondary recovers first, then the clock controller tracks to the secondary, then switches over to the primary when the primary recovers. If the primary recovers first, the clock controller tracks to the primary and continues to do so even if the secondary recovers.

If the command “track to secondary” is given, the clock controller tracks to the secondary reference and continuously monitors the quality of both primary and secondary references. If the secondary goes out of specification, the clock controller automatically tracks to primary provided that is within specifications. On failure (both out of specification), the clock controller enters the HOLDOVER mode and continuously monitors both references. An automatic switchover is initiated to the reference that recovers first. If the primary recovers first, the clock controller tracks to the primary, but switches over to the secondary when the secondary recovers. If the secondary recovers first, the clock controller tracks to the secondary even if the primary recovers.

To prevent chatter due to repeated automatic switching between primary and secondary reference sources, a time-out mechanism of at least 10 seconds is implemented.

## **Digital to analog converter**

The Digital to Analog Converter (DAC) enables the microprocessor to track, hold, and modify the error signal generated in the digital PLL.

The firmware uses the available memory on the clock controller to provide error-burst detection and correction. Temporary holdover occurs in the momentary absence of the reference clock.

### **Holdover and free-run**

In the temporary absence of a synchronization reference signal, or when sudden changes occur on the incoming reference due to error bursts, the clock controller provides a stable holdover. Free-run mode is initiated when the clock controller has no record of the quality of the incoming reference clock.

If the command “free run” is given, the clock controller enters the free-run mode and remains there until a new command is received. Free-run automatically initiates after the clock controller has been enabled.

### **CPU-MUX bus interface**

A parallel I/O port on the clock controller provides a communication channel between the clock controller and the CPU.

### **Signal conditioning**

Drivers and buffers are provided for all outgoing and incoming lines.

### **Sanity timer**

The sanity timer resets the microprocessor in the event of system hang-up.

### **Microprocessor**

The microprocessor does the following:

- communicates with software
- monitors two references
- provides a self-test during initialization
- minimizes the propagation of impairments on the system clock due to errors on the primary or secondary reference clocks

### **Reference Clock Selection**

The DTI/PRI card routes its reference to the appropriate line on the backplane. The clock controller distributes the primary and secondary references and ensures that no contention is present on the REFCLK1

backplane line. It designates the DTI/PRI motherboard as a primary reference source. The secondary reference is obtained from another DTI/PRI card, which is designated by a technician. No other clock sources are used.

## External timing interface

The clock controller provides an external timing interface and accepts two signals as timing references. An external reference is an auxiliary timing clock which is bridged from a traffic carrying signal and is not intended to be a dedicated non-traffic-bearing timing signal. The clock controller uses either the external/auxiliary references or the DTI/PRI references.

## Hardware integrity and regulatory environment

The clock controller complies with the following hardware integrity and regulatory specifications:

Item	Specification
EMI	FCC part 15 sub- part J CSA C108.8 CISPR publication 22
ESD	IEC 801-2
Temperature	IEC 68-2-1 IEC 68-2-2 IEC 68-2-14
Humidity	IEC 68-2-3
Vibration/Shock	IEC 68-2-6 IEC 68-2-7 IEC 68-2-29 IEC 68-2-31 IEC 68-2-32





---

# NTAK79 2.0 Mb PRI card

---

## Contents

This section contains information on the following topics:

<a href="#">Introduction</a> . . . . .	745
<a href="#">Physical description</a> . . . . .	746
<a href="#">Functional description</a> . . . . .	751
<a href="#">Architecture</a> . . . . .	752

## Introduction

The NTA79 2.0 Mb Primary Rate Interface (PRI) card provides a 2.0 Mb interface and an onboard D-channel handler (DCH). The NTA79 card also includes an onboard clock controller (equivalent to the NTA20 Clock Controller) that can be manually switched into or out of service.

The NTA79 card does not support the NTB51 downloadable D-channel handler daughterboard.

You can install this card in slots 1 through 4 in the MG 1000S. The card is not supported in the MG 1000S Expansion.

**Note:** Up to three four trunk cards are supported in each MG 1000S.

**IMPORTANT!**

Each MG 1000S that has a digital trunk **must** have a clock controller clocked to an external reference clock.

*Note:* Clocking slips can occur between MG 1000S systems that are clocked from different Central Offices (COs) if the COs are not synchronized. The slips can degrade voice quality.

## Physical description

The NTAk79 uses a standard 9.5" by 12.5" multi-layer printed circuit board. The faceplate is 7/8" wide. The NTAk79 circuit card has a total of seven faceplate LEDs. Five of the LEDs are directly associated with the operation of the Primary Rate interface (PRI). The remaining two LEDs are associated with the on-board Clock Controller and the on-board D-channel interface (DCHI). The LEDs are described in Table 239.

**Table 239**  
**NTAk79 LEDs (Part 1 of 3)**

LED	State	Definition
<b>OOS</b>	On (Red)	The NTAk79 2 MB PRI circuit card is disabled or out-of-service.
	Off	The NTAk79 2 MB PRI is not in a disabled state.
<b>ACT</b>	On (Green)	The NTAk79 2 MB PRI circuit card is in an active state.
	Off	The NTAk79 2 MB PRI is in a disabled state. The OOS LED will be red.

**Table 239**  
**NTAK79 LEDs (Part 2 of 3)**

LED	State	Definition
<b>RED</b>	On (Red)	A red alarm state has been detected. This represents a local alarm state of: Loss of Carrier (LOS) Loss of Frame (LFAS), or Loss of CRC Multiframe (LMAS).
	Off	No red (local) alarm.
<b>YEL</b>	On (Yellow)	A yellow alarm state has been detected. This represents a remote alarm indication from the far end. The alarm can be either Alarm Indication (AIS) or Remote Alarm (RAI).
	Off	No yellow (remote) alarm.
<b>LBK</b>	On (Green)	2 MB PRI is in loop-back mode.
	Off	2 MB PRI is not in loop-back mode.
<b>CC</b>	On (Red)	The clock controller is switched on and has been disabled by the software.
	On (Green)	The clock controller is switched on and is either locked to a reference or in free run mode.
	Flashing (Green)	The clock controller is switched on and attempting to lock on to a reference (tracking mode). If the LED flashes continuously over an extended period of time, check the CC STAT in LD 60. If the CC is tracking this can be an acceptable state. Check for slips and related clock controller error conditions. If none exist, then this state is acceptable, and the flashing is identifying jitter on the reference.

**Table 239**  
**NTAK79 LEDs (Part 3 of 3)**

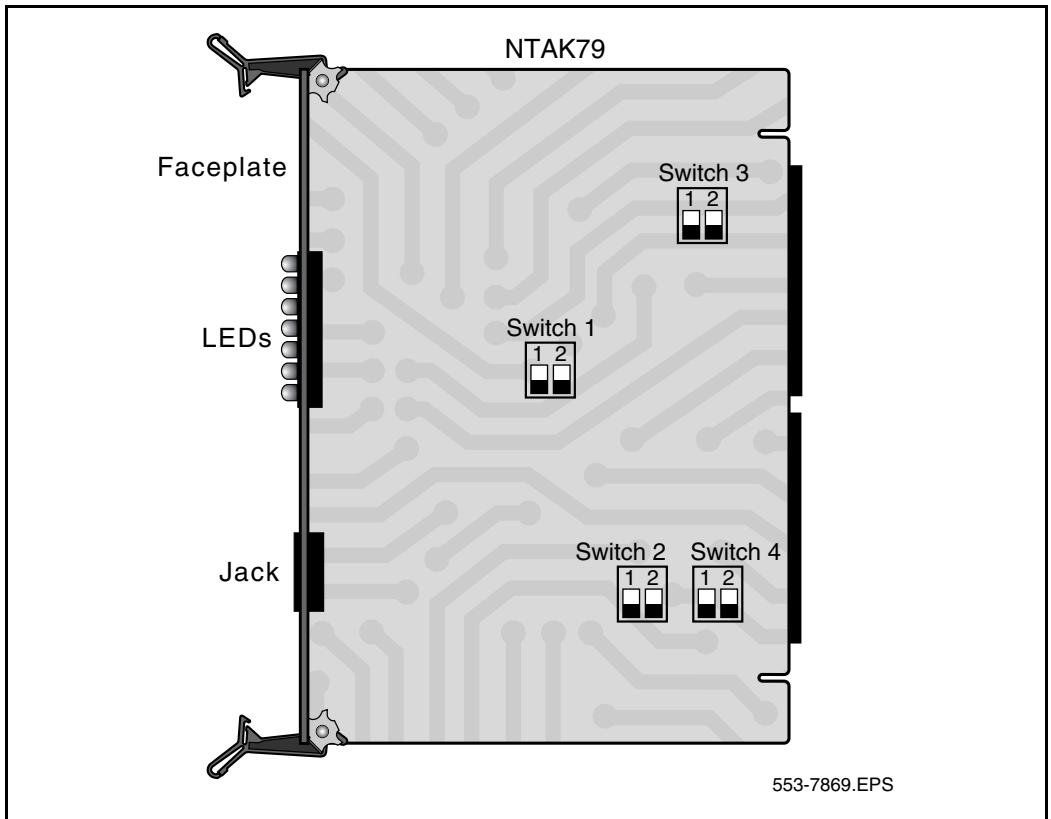
LED	State	Definition
DCH	On (Red)	DCH is switched on and disabled.
	On (Green)	DCH is switched on and enabled, but not necessarily established.
	Off	DCH is switched off.

### NTAK79 switches

The NTAK79 card incorporates four on-board dip switches. The tables that follow provide information on the various settings and related functions of these switches.

*Note:* The ON position for all the switches is towards the bottom of the card. This is indicated by a white dot printed on the board adjacent to the bottom left corner of each individual switch.

Figure 165  
NTAK79 card with switch locations



### Switch SW1 – DCHI Configuration

This switch enables/disables the on-board DCHI and sets the operating mode of the DCHI. DPNSS1 mode is not supported at this time. For all other countries that do not use DPNSS, use Q.931 mode.

**Table 240**  
**Switch SW1**

Switch	Down (On)	Up (Off)
SW 1-1	enable DCHI	disable DCHI
SW 1-2	DPNSS1/DASS2	Q.931

### Switch SW2 – Carrier Impedance Configuration

This switch sets the carrier impedance to either 120 ohms or 75 ohms. Twisted pair cable is usually associated with 120 ohms. Coaxial cable is usually associated with the 75 ohms setting.

**Table 241**  
**Switch SW2**

Cable Type	SW 2-1	SW 2-2
75 ohms	Up (Off)	Down (On)
120 ohms	Down (On)	Up (Off)

### Switch SW3 – Clock Controller Configuration

This switch enables/disables (H/W) the on-board Clock Controller. Disable the SW 3-2 if the on-board clock controller is not in use.

**Table 242**  
**Switch SW3**

Switch	Down (On)	Up (Off)	Note
SW 3-1	—	—	Spare
SW 3-2	Disabled	Enabled	

### Switch SW4 – Carrier Shield Grounding

This switch enables for the selective grounding of the Tx / Rx pairs of the carrier cable. Closing the switch (down position) applies Frame Ground (FGND) to the coaxial carrier cable shield, creating a 75 ohms unbalanced configuration. This applies only to the NTBK05CA cable.

**Table 243**  
**Switch SW4**

Switch	Down (On)	Up (Off)
SW 4-1	Rx – FGND	Rx – OPEN
SW 4-2	Tx – FGND	Tx – OPEN

*Note:* The usual method is to ground the outer conductor of the receive coaxial signal.

### Power requirements

The NTAK79 obtains its power from the backplane, drawing maximums of 2 A on +5 V, 50 mA on +12 V and 50 mA on –12 V.

### Environment

The NTAK79 meets all applicable Nortel Network's operating specifications.

### Functional description

The NTAK79 card provides the following features and functions:

- recovery of the 2.048 kbps data by the CEPT receiver, at signal levels which have been attenuated by up 10 dB
- control of CEPT line density using HDB3 which provides 64 kbps clear channel
- performance monitoring of the receive carrier by means of Bipolar Violations (BPV), Slips, CRC-4 (CRC), and Frame Bit Errors (FBER)

- monitoring of receive carrier alarms including AIS, LOS, and RAI
- transmission of remote alarm when instructed
- slip-buffering receive messages
- supporting National and International bits in time slot 0
- on-board clock controller
- onboard D-channel interface
- 32 software-selectable Tx & Rx Pad values
- conversion of PCM commanding Laws (A-A, u-u, A-u, u-A)
- Card-LAN for maintenance communication

## Architecture

The main functional blocks of the NTAK79 architecture include:

- DS-30X interface
- A07 signaling interface
- digital pad
- carrier interface
- CEPT transceiver
- SLIP control
- D-channel support interface
- 8031 microcontroller
- Card-LAN / echo / test port interface

### DS-30X interface

The NTAK79 interfaces to one DS-30X bus which contains 32 byte-interleaved timeslots operating at 2.56 Mb. Each timeslot contains 10 bits in A10 message format; eight are assigned to voice/data (64 kbps), one to signaling (8 kbps), and one is a data valid bit (8 kbps).



The incoming serial bit stream is converted to 8-bit parallel bytes to be directed to padding control.

The signaling bits are extracted and inserted by the A07 signaling interface circuitry. The DS-30X timeslot number is mapped to the PCM-30 channel number. Timeslots 0 and 16 are currently unused for PCM.

### Digital PAD

Software selects A-Law or Mu-Law and one of 32 possible PAD values for each channel. These values are provided in a PROM through which the data is routed. The idle code for A-Law is 54H and for Mu-Law is 7FH. The unequipped code is FFH for both A-Law and Mu-Law. As the idle code and unequipped code can be country dependent, the software instructs the NTAk79 to use different codes for each direction. The 32 digital pads available are listed in Table 244. The values shown are attenuation levels; 1.0 dB is 1 dB of loss and -1.0 dB is 1 dB of gain.

**Table 244**  
**Digital pad values and offset allocations (Part 1 of 2)**

PAD SET 0		PAD SET 1	
Offset	PAD	Offset	PAD
0	0.6 dB	0	0.0 dB
1	1.0 dB	1	-1.0 dB
2	2.0 dB	2	-2.0 dB
3	3.0 dB	3	-3.0 dB
4	4.0 dB	4	-4.0 dB
5	5.0 dB	5	-5.0 dB
6	6.1 dB	6	-6.0 dB
7	7.0 dB	7	-7.0 dB
8	8.0 dB	8	-8.0 dB
9	9.0 dB	9	-9.0 dB

**Table 244**  
**Digital pad values and offset allocations (Part 2 of 2)**

PAD SET 0		PAD SET 1	
Offset	PAD	Offset	PAD
10	10.0 dB	10	-10.0 dB
11	11.0 dB	11	spare
12	12.0 dB	12	spare
13	13.0 dB	13	spare
14	14.0 dB	14	Idle Code
15	spare	15	Unassigned Code

## Signaling interface

The signaling interface consists of the A07 DS-30X signaling controller. This interface provides an 8 Kbps signaling link through the DS-30X timeslot zero data bit zero. Messages are 3 bytes in length.

## Carrier interface

The E1 interface connection to the external digital carrier is provided by the line interface chip. This chip provides accurate pulse shaping to meet the CCITT pulse mask requirements. It provides clock recovery functions on the receive side as well as tolerance to jitter and wander in the received bit stream.

## Impedance matching

The line interface provides for the use of either 75 ohms coaxial or 120 ohms twisted pair cable. The impedance is selected by a switch, as shown in Table 245.

**Table 245**  
**Impedance matching switch selection**

Cable	On	Off
75 ohms	S2	S1
120 ohms	S1	S2

*Note:* The ON position for all the switches is towards the bottom of the card. This is indicated by a white dot printed on the board next to the bottom left corner of each individual switch.

## Carrier grounding

The NTAK79 card provides the capability of selectively grounding the shield of the Tx and/or Rx pairs of the carrier. Closing (down) the on-board switch applies FGND to the appropriate carrier cable shield. The switch settings are shown in Table 246.

**Table 246**  
**Carrier shield grounding switch settings**

Switch	Carrier Pair	On	Off
S4-1	Rx shield	Open	GND
S4-2	Tx shield	Open	GND

## Receiver functions

The receiver extracts data and clock from an AMI (Alternate Mark Inversion) coded signal and outputs clock and synchronized data. The receiver is sensitive to signals over the entire range of cable lengths and requires no equalization. The clock and data recovery meets or exceeds the jitter specifications of the CCITT recommendation G.823, and the jitter attenuation

requirements of the CCITT recommendation G.742. This provides jitter attenuation increasing from 0 dB to 60 dB over the frequency range from about 6 Hz to 6 KHz.

### **Transmitter functions**

The transmitter takes the binary (dual unipolar) data from the PCM transceiver and produces bipolar pulses which conform to the CCITT recommendation G.703 pulse shape.

### **Loopbacks**

The remote loopback function causes the device to transmit the same data that it receives, using the jitter attenuated receive clock. The data is also available at the receive data outputs. Local loopback causes the transmit data and clock to appear at the receive clock and data outputs. This data is also transmitted on the line unless transmit AIS is selected.

## **CEPT transceiver**

The transmitter and receiver functions are used for synchronization, channel, and signal extraction. The functions meet applicable specifications of the CCITT recommendation G.703 and G.732.

The transceiver provides transmit framing based on the 2.048 MHz clock derived from the DS-30X system clock and 1 KHz framing pulse.

## **Slip control**

Slip control provides organized recovery of PCM when the clock recovered from the external facility is at a different frequency than the local clock.

## **D-channel support interface**

The D-channel support interface is a 64 Kbps, full-duplex serial bit stream configured as a DCE device. The data signals include:

- Receive data output
- transmit data input

- receive clock output
- transmit clock output

The receive and transmit clocks have slightly different bit rates from each other, as determined by the transmit and receive carrier clocks.

The NTAk79 has an onboard D-Channel Handler Interface (DCHI). It is the equivalent to a single port of an NTAk02 SDI/DCH pack. This enables for a completely operational ISDN PRA link with clock synchronization and D-channel on a single circuit card.

The onboard D-channel has one status LED on the NTAk79 faceplate to indicate enabled/disabled states. See Table 239 on [page 746](#).

The on-board DCHI can be operated in two separate modes as defined by an on-board dip switch. It can operate in a standard DCHI mode common to most ISDN standard countries. The U.K. specific mode that uses the DPNSS format is not supported at this time.

**Table 247**  
**Settings for the DCHI dip switch (SW1)**

Switch	Function	On	Off
S1-1	En/Dis	Enabled	Disabled
S1-2	F/W Mode	DPNSS (not supported at this time)	DCHI

### **DCHI special applications connection**

The connection between the PRI2 and the on-board D-channel Handler Interface card is also available at the MDF connector. Connections are made to these pins for normal on-board DCHI operation. They can also be used for future or special applications.

The signals conform to the EIA RS-422 standard.

## Card-LAN interface

A Dual Port UART handles the functions of the serial ports for the Card-LAN serial link and the echo canceller/test port interface. The echo/test interface is an asynchronous 4800 bps 8-bit connected to port A of the UART. The Card-LAN interface is an asynchronous 19.2 kbps 9 bit start/stop connected to port B of the UART.

The connection to the echo canceler/test port is available at the backplane/MDF connector. The signals at this port conform to the EIA RS-232C standard.

## Clock controller interface

The clock controller circuitry on the NTAK79 is identical to that of the NTAK20 clock controller.

Though several DTI/PRI packs can exist in one system, only one clock controller may be activated. All other DTI/PRI clock controllers must be switched off.

### Clocking modes

The clock controller can operate in one of two modes:

- tracking
- non-tracking (also known as free-run)

### *Tracking mode*

There are two stages to clock controller tracking:

- tracking a reference, and
- locked onto a reference.

When tracking a reference, the clock controller uses an algorithm to match its frequency to the frequency of the incoming clock. When the frequencies are very near to being matched, the clock controller is locked onto the reference. The clock controller will make small adjustments to its own frequency until both the incoming and system frequencies correspond.

If the incoming clock reference is stable, the internal clock controller will track it, lock onto it, and match frequencies exactly. Occasionally, however, environmental circumstances will cause the external or internal clocks to drift. When this happens, the internal clock controller will briefly enter the tracking stage. The green LED will flash momentarily until the clock controller is locked onto the reference once again.

If the incoming reference is unstable, the internal clock controller will continuously be in the tracking stage, with the LED flashing green all the time. This condition does not present a problem, rather, it shows that the clock controller is continually attempting to lock onto the signal. If slips are occurring, however, it means that there is a problem with the clock controller or the incoming line.

### ***Free-run (non-tracking)***

In free-run mode, the clock controller does not synchronize on any source, it provides its own internal clock to the system. This mode can be used when the CS 1000S, CS 1000M Cabinet, and Meridian 1 PBX 11C Cabinet are used as a master clock source for other systems in the network. Free-run mode is undesirable if the CS 1000S, CS 1000M Cabinet, and Meridian 1 PBX 11C Cabinet are intended to be a slave. It can occur, however, when both the primary and secondary clock sources are lost due to hardware faults or when invoked by using software commands.

### **Clock controller functions and features**

The NTA79 clock controller functions and features include:

- phase lock to a reference, generate the 10.24 MHz system clock, and distribute it to the CPU through the backplane. Up to two references at a time are accepted
- primary to secondary switchover (auto-recovery is provided)
- prevent chatter
- error burst detection and correction, holdover, and free running capabilities
- compliance with 2.0Mb CCITT specifications
- software communication

- jitter filtering
- use of an algorithm to detect crystal aging and to qualify clocking information

### **Reference switchover**

Switchover may occur in the case of reference degradation or reference failure. When performance of the reference degrades to a point where the system clock is no longer allowed to follow the timing signal, then the reference will be said to be out of specification. If the reference being used is out of specification and the other reference is still within specification, an automatic switchover is initiated without software intervention. If both references are out of specification, the clock controller provides holdover.

### **Autorecovery and chatter**

If the software command “track to primary” is given, the clock controller tracks to the primary reference and continuously monitors the quality of both primary and secondary references. If the primary becomes out of specification, the clock controller automatically tracks to secondary provided that it is within specifications. On failure (both out of specification), the clock controller enters the HOLDOVER mode and continuously monitors both references. An automatic switchover is initiated to the reference that recovers first. If the secondary recovers first, then the clock controller tracks to the secondary, but switches over to the primary when the primary recovers. If the primary recovers first, the clock controller tracks to the primary.

If the software command “track to secondary” is given, the clock controller tracks to the secondary reference and continuously monitors the quality of both primary and secondary references. If the secondary becomes out of specification, the clock controller automatically tracks to primary provided that it is within specifications. On failure (both out of spec.), the clock controller enters the HOLDOVER mode and continuously monitors both references. An automatic switchover is initiated to the reference that recovers first. If the primary recovers first, then the clock controller tracks to the primary, but switches over to the secondary whenever the secondary recovers. If the secondary recovers first, then the clock controller tracks to the secondary.



A time-out mechanism prevents chatter due to repeated automatic switching between primary and secondary reference sources.

### **Holdover and free-run**

In the temporary absence of a synchronization reference signal, or when sudden changes occur on the incoming reference due to error bursts, the clock controller provides a stable holdover. The free-run mode is initiated when the clock controller has no record of the quality of the incoming reference clock.

If the software command “free run” is given, the clock controller enters the free-run mode and remains there until a new command is received. Note that the free-run mode of operation is automatically initiated after the clock controller is enabled.

### **Reference clock selection through software**

The NTAK79 has the necessary hardware for routing its reference to the appropriate line on the backplane.

The software is responsible for the distribution of the secondary references and ensures that no contention is present on the REFCLK1 backplane line. The software designates the NTAK79 as the primary reference source to the clock controller. The secondary reference is obtained from another NTAK79 card, which is designated by a technician. No other clocks originating from other NTAK79 circuit cards are used.

The clock controller provides an external timing interface and is capable of accepting two signals as timing references. In this case, an external reference refers to an auxiliary timing source which is bridged from a traffic carrying signal. This is not intended to be a dedicated non-traffic bearing timing signal. The clock controller uses either the two external/auxiliary references or the NTAK79 references.



---

# NTAK93 D-channel Handler Interface daughterboard

---

## Contents

This section contains information on the following topics:

<a href="#">Introduction</a> . . . . .	763
<a href="#">Physical description</a> . . . . .	764
<a href="#">Functional description</a> . . . . .	765

## Introduction

The NTAk93 provides the D-channel handler interfaces required by the ISDN PRI trunk.

The DCHI performs D-channel Layer 2 message processing and transfers Layer 3 signaling information between two adjacent network switches. It is mounted on the NTAk09 1.5 Mb DTI/PRI card or the NTBk50 2.0 Mb PRI card (installed in the MG 1000S) using standoff reference pins and connectors. The NTAk93 daughterboard, when mounted on the NTBk50 PRI digital trunk card, is addressed in the same slot as the NTBk50. The NTAk93 daughterboard can use SDI I/O addresses 1 to 15 and port 1.

The NTAk93 provides the following features and functions:

- D-channel interface or DPNSS interface
- Special features included for LAPD implementation at DCH:

- system parameters are service changeable (system parameters are downloaded from software)
- incoming Layer 3 message validation procedures are implemented in the D-PORT firmware
- supported message units and information elements can be service changed
- translation of the CCITT message types information elements into a proprietary coding scheme for faster CPU operation
- convention of IA5-encoded digits to BCD-encoded digits for incoming layer 3 messages for faster CPU operation
- self-test
- loopback

## Physical description

The DCH function can be installed in the main and IP expansion cabinets. The DTI/PRI card which carries a DCH daughterboard resides in the main and IP expansion cabinets.

## Faceplate LEDs

### NTAK09 1.5 Mb PRI and NTBK50 2.0 MB PRI cards

LEDs are located on the faceplate of the NTAK09 and NTBK50 cards. The DCHI LED is dual-color (red and green). The LEDs are described in Table 248.

**Table 248**  
**Faceplate LEDs**

State	Definition
On (Red)	NTAK93 is equipped and disabled.
On (Green)	NTAK93 is equipped and enabled, but not necessarily established.
Off	NTAK93 is not equipped.

## Power consumption

Power consumption is +5 V at 750 mA; +12 V at 5 mA; and -12 V at 5 mA.

## Functional description

The main functional blocks of the NTAK93 architecture include the following.

### Microprocessors

One microprocessor does the following:

- handles data transfer between each pair of serial ports and software
- reports the status of each port
- takes commands from software to control the activities of the ports

The microprocessors also handle some D-channel data processing in DCHI mode.

## **DMA controller**

A Z80A-DMA chip controls the data transfer between local RAM memory and communication ports. The DMA channels are only used in the receive direction (from line to SSC), not in the transmit direction.

## **Random Access Memory (RAM)**

A total of 32 KBytes of RAM space for each pair of ports is used as the communication buffer and for firmware data storage.

## **Read Only Memory (ROM)**

A total of 32K bytes of ROM space for each pair of ports is reserved as a code section of the DCH-PORT firmware.

## **LAPD data link/asynchronous controller**

One chip controls each pair of independent communication ports. It performs the functions of serial-to-parallel and parallel-to-serial conversions, error detection, and frame recognition (in HDLC). The parameters of these functions are supplied by the DCH-PORT firmware.

## **Counter/timer controller**

Two chips are used as real-time timers and baud-rate generators for each pair of communication ports.

## **Software interface circuit**

This portion of the circuit handles address/data bus multiplexing, the interchange of data, commands, and status between the on board processors and software. It includes transmit buffer, receive buffer, command register, and status register for each communication channel.

## **DPNSS/DCHI Port**

The mode of operation of the DCH-PORT is controlled by a switch setting on the NTAk09/NTBK50. For DPNSS the switch is ON; for DCHI it is OFF.

The port will operate at:

Data Rate	56kbps, 64kbps
Duplex	Full
Clock	Internal / External
Interface	RS422

The address of ports is selected by hardwired backplane card address. Port characteristics and LAPD parameters are downloaded from software.

## **D-Port — SDTI/PRI interface**

Below is a brief description of signals. When connected to SDTI/PRI, DCHI-PORT is considered Data Terminal Equipment (DTE):

- SDA, SDB: Transmit Clock provided by SDTI/PRI
- RTA, RTB: Receive Clock provided by SDTI/PRI
- RR, CS: SPDC ready signal provided by DCHI-PORT
- TR: D-PORT ready signal provided by DCHI-PORT
- RDA, RDB: Incoming serial data bit stream, driven by SDTI/PRI
- SDA, SDB: Transmit serial data bit stream driven by DCHI-PORT





---

# NTBK22 MISP card

---

## Contents

This section contains information on the following topics:

Introduction . . . . .	769
Physical description . . . . .	769
Functional description . . . . .	770

## Introduction

The NTBK22 Multi-Purpose ISDN Signaling Processor (MISP) card is a microprocessor-controlled signaling processor that performs Data Link (Layer 2) and Network (Layer 3) processing associated with ISDN BRI and the OSI protocol.

## Physical description

The MISP occupies one slot in the MG 1000S. It uses one of the network loops to interface with SILCs and UILCs and to provide 32 timeslots for D-channel signaling and packet data transmission. The other loop address is used to communicate with the Call Server.

You can install this card in slots 1 through 4 in the MG 1000S. The card is not supported in the MG 1000S Expansion.

**Note:** When configuring BRI trunks, the MISP (NTBK22) card must be co-located in the same MG 1000S as the SILC (NT6D70) and UILC (NT6D71) cards the MISP is supporting.

Refer to *ISDN Basic Rate Interface: Installation and Configuration* (553-3001-218) and *ISDN Basic Rate Interface: Features* (553-3001-380) for additional information.

## Functional description

Each MISP can support 4 line cards (UILC or SILC or any combination of the two). Each line card supports 8 DSLs, therefore each MISP supports 32 DSLs. Since each DSL uses two B-channels and one D-channel the MISP supports 64 B-channels and 32 D-channels. If the MISP is carrying packet data, it must dedicate one of its D-channels to communicate with the external packet handler. In this case the MISP supports only 31 DSLs.

The main functions of the MISP are:

- communicate with the Call Server CPU to report ISDN BRI status and receive downloaded application software and configuration parameters
- manage Layer 2 and Layer 3 signaling that controls call connection and terminal identification
- control terminal initialization and addressing
- assign B-channels for switched voice and data transmission by communicating with the BRI terminal over the D-channel and allocating to it an idle B-channel with appropriate bearer capabilities
- separate D-channel data from signaling information and route the data to the packet handler
- send call control messages to ISDN BRI terminals over the D-channel

## Micro Processing Unit (MPU)

The MPU coordinates and controls data transfer and addressing of the peripheral devices and communicates with the CPU using a message channel on the CPU bus. The tasks that the MPU performs depend on the interrupts it receives. The interrupts are prioritized by the importance of the tasks they control.

## High-Level Data Link Controller (HDLC)

The HDLC is a format converter that supports up to 32 serial channels that communicate at speeds up to 64 kbps. The HDLC converts messages into the following two message formats:

- a serially transmitted, zero-inserted, CRC protected message that has a starting and an ending flag
- a data structure

## CPU to MISP bus interface

Information exchange between the CPU and the MISP is performed with packetized messages transmitted over the CPU bus. This interface has a 16-bit data bus, an 18-bit address bus, and interrupt and read/write control lines.

This interface uses shared Static Random Access Memory (SRAM) as a communication exchange center between the CPU and the MPU. Both the CPU and the MPU can access this memory over the transmit and receive channels on the bus.

## MISP network bus interface

The network bus interface:

- converts bit interleaved serial data received from the network bus into byte interleaved data for transmission over the 32 time slots used by the HDLC controller
- accepts byte interleaved data transmitted from the HDLC controller and converts it into a bit interleaved data stream for transmission over the network bus

## Power consumption

Power consumption is +5V at 2 A; +15V at 50 mA; and -15V at 50 mA.



---

# NTBK50 2.0 Mb PRI card

---

## Contents

This section contains information on the following topics:

<a href="#">Introduction</a> . . . . .	773
<a href="#">Physical description</a> . . . . .	774
<a href="#">Functional description</a> . . . . .	777
<a href="#">Architecture</a> . . . . .	778

## Introduction

The NTBK50 2.0 Mb PRI card provides a 2.0 Mb PRI interface. It supports the NTAK20 clock controller daughterboard and either the NTAK93 D-channel interface or the NTBK51 Downloadable D-channel handler. The NTAK93 DCHI daughterboard provides identical performance to the on-board NTAK79 DCHI. The NTBK51 DDCH daughterboard provides support for protocols based on the MSDL platform.

You can install this card in slots 1 through 4 in the MG 1000S. The card is not supported in the MG 1000S Expansion.

**IMPORTANT!**

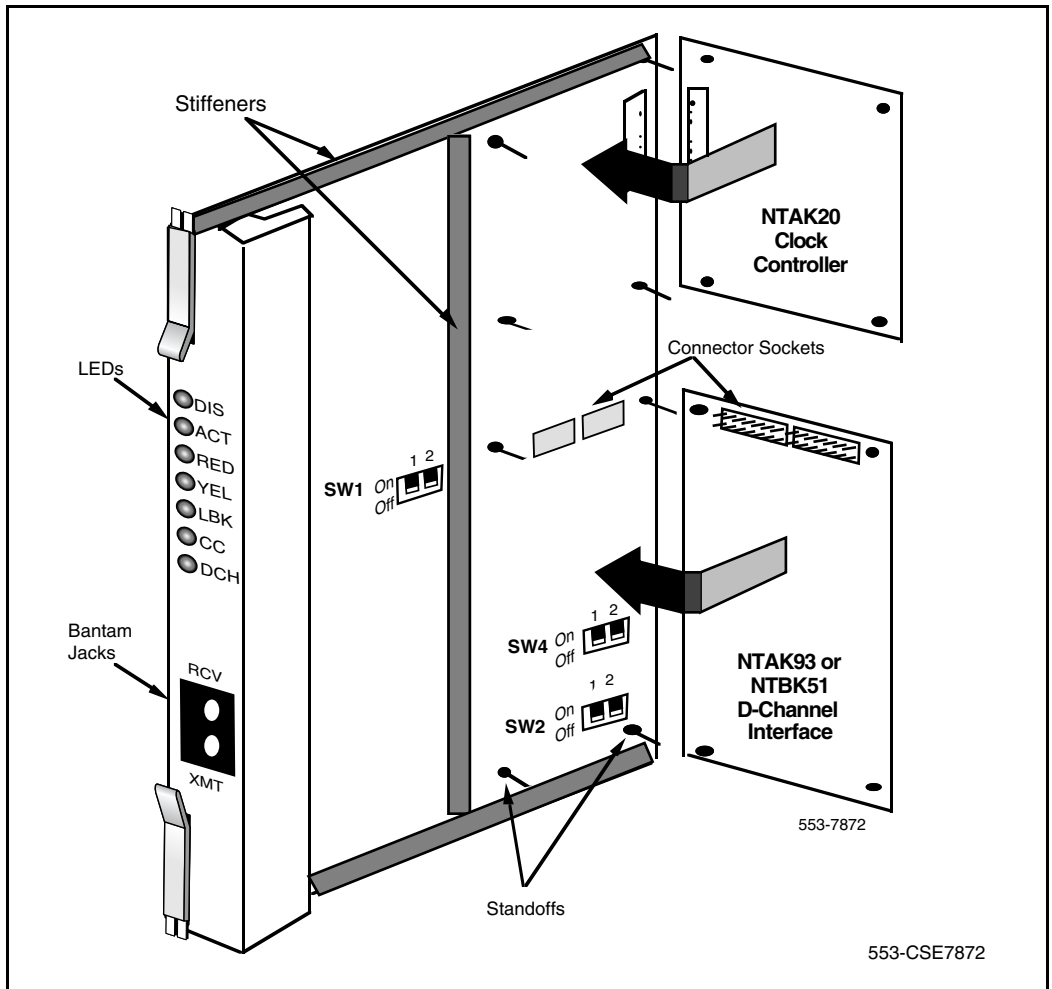
Each MG 1000S that has a digital trunk **must** have a clock controller clocked to an external reference clock.

*Note:* Clocking slips can occur between MG 1000S systems that are clocked from different Central Offices (COs), if the COs are not synchronized. The slips can degrade voice quality.

## Physical description

The NTBK50 uses a standard 9.5" by 12.5" multi-layer printed circuit board. The faceplate is 7/8" wide and contains seven LEDs. See Figure 166 on [page 775](#).

Figure 166  
NTBK50 2.0 Mb PRI card with daughterboards



The LEDs are described in Table 249.

**Table 249**  
**NTBK50 faceplate LEDs (Part 1 of 2)**

LED	State	Definition
<b>OOS</b>	On (Red)	The NTBK50 2.0 Mb PRI circuit card is disabled or out-of-service. Also, the state of the card after power-up, completion of self test, and exiting remote loopback.
	Off	The NTBK50 2.0 Mb PRI is not in a disabled state.
<b>ACT</b>	On (Green)	The NTBK50 2.0 Mb PRI circuit card is in an active state.
	Off	The NTBK50 2.0 Mb PRI is in a disabled state. The OOS LED is red.
<b>RED</b>	On (Red)	A red alarm state has been detected. This represents a local alarm state of Loss of Carrier (LOS), Loss of Frame (LFAS), or Loss of CRC Multiframe (LMAS).
	Off	No red (local) alarm.
<b>YEL</b>	On (Yellow)	A yellow alarm state has been detected. This represents a remote alarm indication from the far end. The alarm may be either Alarm Indication (AIS) or Remote Alarm (RAI).
	Off	No yellow (remote) alarm.
<b>LBK</b>	On (Green)	2.0 Mb PRI is in loop-back mode.
	Off	2.0 Mb PRI is not in loop-back mode.
<b>CC</b>	On (Red)	The clock controller is software disabled.
	On (Green)	The clock controller is enabled and is either locked to a reference or is in free run mode.



**Table 249**  
**NTBK50 faceplate LEDs (Part 2 of 2)**

LED	State	Definition
	Flashing (Green)	NTAK20 is equipped and is attempting to lock (tracking mode) to a reference. If the LED flashes continuously over an extended period of time, check the CC STAT in LD 60. If the CC is tracking this can be an acceptable state. Check for slips and related clock controller error conditions. If none exist, then this state is acceptable, and the flashing is identifying jitter on the reference.
	Off	The clock controller is not equipped.
<b>DCH</b>	On (Red)	DCH is disabled.
	On (Green)	DCH is enabled, but not necessarily established.
	Off	DCH is not equipped.

## Power requirements

The NTBK50 obtains its power from the backplane, drawing up to 2 A on +5 V, 35 mA on +15 V and 20 mA on -15 V.

## Environment

The NTBK50 meets all applicable Nortel operating specifications.

## Functional description

NTBK50 provides the following features and components:

- recovery of the 2.048 kbps data by the CEPT receiver, at signal levels which have been attenuated by up to 10 dB
- control of CEPT line density using HDB3 which provides 64 kbps clear channel
- performance monitoring of the receive carrier by means of Bipolar Violations (BPV), Slips, CRC-4 (CRC), and Frame Bit Errors (FBER)

- monitoring of receive carrier alarms including AIS, LOS, and RAI
- transmission of remote alarm when instructed
- slip-buffering receive messages
- support of National and International bits in timeslot 0
- clock controller daughterboard
- D-channel interface daughterboard
- downloadable D-channel handler daughterboard
- 32 software-selectable Tx and Rx Pad values
- conversion of PCM commanding Laws (A-A, u-u, A-u, u-A)
- Card-LAN for maintenance communication

## Architecture

The main functional blocks of the NTBK50 architecture are:

- DS-30X interface
- A07 signaling interface
- digital pad
- carrier interface
- CEPT transceiver
- SLIP control
- D-channel support interface
- clock controller interface
- Card-LAN / echo / test port interface
- 80C51FA Microcontroller

### DS-30X interface

NTBK50 interfaces to one DS-30X bus which contains 32-byte interleaved timeslots operating at 2.56 Mb. Each timeslot contains 10 bits in A10

message format; eight are assigned to voice/data (64 Kbps), one to signaling (8 Kbps), and one is a data valid bit (8 Kbps).

The incoming serial bit stream is converted to 8-bit parallel bytes to be directed to padding control. The signaling bits are extracted and inserted by the A07 signaling interface circuitry. Timeslots 0 and 16 are currently unused for PCM.

### Digital PAD

The software selects A-Law or  $\mu$ -Law and one of 32 possible PAD values for each channel. These values are provided in a PROM through which the data is routed. The idle code for A-Law is 54H and for  $\mu$ -Law is 7FH. The unequipped code is FFH for both A-Law and  $\mu$ -Law.

As the idle code and unequipped code can be country dependent, the software instructs the NTBK50 to use different codes for each direction. The 32 digital pads available are illustrated in Table 250 on page 779. The values shown are attenuation levels (1.0dB is 1 dB of loss and -1.0 dB is 1 dB of gain).

**Table 250**  
**Digital Pad - values and offset allocations (Part 1 of 2)**

PAD SET 0		PAD SET 1	
Offset	PAD	Offset	PAD
0	0.6 dB	0	0.0 dB
1	1.0 dB	1	-1.0 dB
2	2.0 dB	2	-2.0 dB
3	3.0 dB	3	-3.0 dB
4	4.0 dB	4	-4.0 dB
5	5.0 dB	5	-5.0 dB
6	6.1 dB	6	-6.0 dB
7	7.0 dB	7	-7.0 dB
8	8.0 dB	8	-8.0 dB

**Table 250**  
**Digital Pad - values and offset allocations (Part 2 of 2)**

PAD SET 0		PAD SET 1	
Offset	PAD	Offset	PAD
9	9.0 dB	9	-9.0 dB
10	10.0 dB	10	-10.0 dB
11	11.0 dB	11	spare
12	12.0 dB	12	spare
13	13.0 dB	13	spare
14	14.0 dB	14	Idle Code
15	spare	15	Unassigned Code

### Signaling interface

The signaling interface consists of the A07 DS-30X signaling controller. This interface provides an 8 Kbps signaling link via the DS-30X timeslot zero data bit zero. Messages are 3 bytes in length.

### Carrier interface

For the E1 interface, the connection to the external digital carrier is provided by the line interface chip. This device provides accurate pulse shaping to meet the CCITT pulse mask requirements. It provides clock recovery functions on the receive side, as well as tolerance to jitter and wander in the received bit stream.

### Impedance matching (Switch SW2)

The line interface provides for the use of either 75 ohms coaxial or 120 ohms twisted pair cable. The impedance is selected by SW2, as shown in Table 251.

**Table 251**  
**Impedance matching switch settings**

Cable Type	SW 2-1
75 ohms	Down (On)
120 ohms	Up (Off)

*Note:* The ON position for all the switches is toward the bottom of the card. This is indicated by a white dot printed on the board next to the bottom left corner of each individual switch.

### Carrier grounding

NTBK50 enables the shield of the Tx and/or Rx pairs of the carrier to be selectively grounded. Closing (down position) the on-board switch applies FGND to the appropriate carrier cable shield. The switch settings are shown in Table 252.

**Table 252**  
**Carrier Shield grounding switch settings**

Switch	Down (On)	Up (Off)
SW 4 – 1	Rx – FGND	Rx – OPEN
SW 4 – 2	Tx – FGND	Tx – OPEN

### Carrier Shield grounding (Switch SW4)

Table 253 lists the Carrier Shield ground switch settings.

**Table 253**  
**Carrier Shield grounding switch settings**

Switch	Down (On)	Up (Off)
SW 4 – 1	Rx – FGND	Rx – OPEN
SW 4 – 2	Tx – FGND	Tx – OPEN

*Note:* The usual method is to ground the outer conductor of the receive coax signal.

### Receiver functions

The receiver extracts data and clock from an AMI (Alternate Mark Inversion) coded signal and outputs clock and synchronized data. The receiver is sensitive to signals over the entire range of cable lengths and requires no equalization. The clock and data recovery meets or exceeds the jitter specifications of the CCITT recommendation G.823 and the jitter attenuation requirements of the CCITT recommendation G.742. This provides jitter attenuation increasing from 0 dB to 60 dB over the frequency range from about 6 Hz to 6 KHz.

### Transmitter functions

The transmitter takes the binary (dual unipolar) data from the PCM transceiver and produces bipolar pulses. This conforms to CCITT recommendation G.703 pulse shape.

### Loopbacks

The remote loopback function causes the far-end device to transmit the same data that it receives, using the jitter attenuated receive clock. The data is additionally available at the far-end receive data outputs. Local loopback causes the transmit data and clock to appear at the near-end clock and receive data outputs. This data is also transmitted on the line unless an Alarm Indication Signal (AIS) is transmitted instead.

## **CEPT transceiver**

The transmitter and receiver functions are used for synchronization, channel, and signal extraction. The functions meet applicable specifications of the CCITT recommendation G.703 and G.732.

The transceiver provides transmit framing based on the 2.048 MHz clock derived from the DS-30X system clock and 1 KHz framing pulse.

## **Slip control**

Slip control provides organized recovery of PCM when the clock recovered from the external facility is at a different frequency with respect to the local clock.

## **D-channel support interface**

The D-channel support interface is a 64 Kbps, full-duplex serial bit stream configured as a DCE device. The data signals include:

- receive data output
- transmit data input
- receive clock output
- transmit clock output

The receive and transmit clocks can be of slightly different bit rates from each other as determined by the transmit and receive carrier clocks.

The NTBK50 supports a D-Channel Handler Interface (DCHI) daughterboard. It is equivalent to a single port of an NTAK02 SDI/DCH card. The NTBK50 also supports a Downloadable D-Channel Handler interface (DDCH) daughterboard. The DDCH brings MSDL D-channel capability to the system.

### **DCHI Configuration for NTAK93 only (SW1)**

The NTAK93 DCHI daughterboard can be operated in two separate modes defined by an on-board dip switch. It can operate in a standard DCHI mode common to most ISDN standard countries. It can also operate in a DPNSS

mode, which is not supported at this time. The DDCH supports only a single port which directly interfaces to the PRI motherboard. See Table 254.

**Table 254**  
**Settings for the DCHI dip switch (SW1)**

Switch	Function	On	Off
S1-1	—	—	—
S1-2	F/W Mode	DPNSS	DCHI

### Card-LAN interface

A Dual Port UART handles the functions of the serial ports for the Card-LAN serial link test port interface. The test interface is an asynchronous 4800 bps 8 bit connected to port A of the UART. The card-LAN interface is an asynchronous 19.2 kbps 9 bit start/stop connected to port B of the UART.

The connection to the test port is available at the backplane/MDF connector.

The signals at this port conform to the EIA RS-232C standard.



---

# NTBK51 Downloadable D-channel Handler daughterboard

---

## Contents

This section contains information on the following topics:

<a href="#">Introduction</a> . . . . .	785
<a href="#">Physical description</a> . . . . .	786
<a href="#">Functional description</a> . . . . .	787
<a href="#">Download operation</a> . . . . .	789

## Introduction

The NTBK51 daughterboard provides Downloadable D-channel Handler (DDCH) interfaces based on the Multipurpose Serial Data Link (MSDL). The DDCH provides a single purpose full-duplex serial port capable of downloading the D-channel application and base software into the card.

The NTBK51 provides the following features and functions:

- ISDN D-channel related protocol
- Selftest
- Loopback
- D-channel loadware including:
  - management and maintenance
  - LAPD- software for data link layer processing

- DCH interface
- layer 3 preprocessor
- traffic reporting including link capacity

## Physical description

The NTBK51 daughterboard interfaces with the system CPU and is mounted on either the NTAK09 1.5 DTI/PRI card or the NTBK50 2 Mb PRI digital trunk card.

You can install this card in:

- slots 1 through 9 in the main cabinet or slots 11-19, 21-29, 31-39, or 41-49 in the expansion cabinets
- slots 1 through 4 in the MG 1000S. The card is not supported in the MG 1000S Expansion

The NTBK51 daughterboard, when installed on the NTAK09 digital trunk card, is addressed in the same slot as the NTAK09.

One NTBK51 daughterboard is required for each PRI link.

LEDs are located on the faceplate of the NTAK09/NTBK50 card. The DCHI LED is a dual-color (red/green). The LED is described in Table 255.

**Table 255**  
**Faceplate LED**

State	Definition
On (Red)	NTBK51 is disabled.
On (Green)	NTBK51 is enabled, but not necessarily established.
Off	NTBK51 is not equipped.

## Functional description

The main functional blocks of the NTBK51 architecture include the following:

- Microprocessors
- Main memory
- Shared memory
- EPROM memory
- Flash EPROM memory
- EEPROM memory
- Serial communication controller
- Sanity timer
- Bus timer

### Microprocessors

One microprocessor handles data transfer between each serial interface and software, reports the status of each port and takes commands from the software to control the activities of the ports. A high performance MPU supports the D-channel from the PRI card and other software applications running simultaneously on other ports of the DDCH card.

The microprocessor performs the following functions:

- sanity check and self tests
- message handling between the CS 1000S, CS 1000M Cabinet, and Meridian 1 PBX 11C Cabinet and the card
- four port serial communication controller handling with Direct Memory Access (DMA)
- program download from the Small System Controller

## **Main memory**

The main 68EC020 system memory is comprised of 1 Mbyte of SRAM and is accessible in 8 or 16 bits. The software, base code and application reside in main RAM and is downloaded from the software through the shared memory.

## **Shared memory**

The shared memory is the interface between the CPU and the 68EC020 MPU. This memory is a 16 Kbyte RAM, expandable to 64 kbytes and accessible in 8 or 16 bits.

## **EPROM memory**

The Bootstrap code resides in this 27C1000 EPROM and is executed on power up or reset.

## **Flash EPROM memory**

Flash EPROM provides non-volatile storage for the DDCH loadware which minimizes the impact to sysload. The Flash EPROM provides an increase in system service with a reduced delay after a brown-out, and faster testing of a hardware pack after it is plugged in.

## **EEPROM memory**

The DDCH uses a 1024 bit serial EEPROM for storing the Nortel product code and a revision level. This information can be queried by the software.

## **Serial communication controller**

The serial controller is the Zilog Z16C35 and is referenced as the Integrated Controller (ISCC). The ISCC includes a flexible Bus Interface Unit (BIU) and four Direct Memory Access (DMA) channels, one for each receive and transmit. The DMA core of the ISCC controls the data transfer between local RAM and the communication ports.

## Sanity timer

A sanity timer is incorporated on the DDCH to prevent the MPU from getting tied-up as the result of a hardware or software fault. If the MPU encounters a hardware or software fault and enters a continuous loop, the sanity timer enables the DDCH to reset itself.

## Bus timer

The bus timer presents an error signal to the MPU if an attempt to access a device did not receive acknowledgment within the bus time-out period of 120 ms.

## Download operation

Downloading is performed in either of two modes: background mode or maintenance mode. Before a download takes place, a D-channel link must be configured. The following situations lead to software downloading:

- during initialization when new software is installed
- when enabling the card or application
- during card reset (due to loss of software or corruption)
- during a background audit

## System initialization

When new base or application software is installed on a CS 1000S, CS 1000M Cabinet, and Meridian 1 PBX 11C Cabinet, the download decision is made during system initialization. The actual MSDL base software download is done in background mode and can take several minutes to complete, depending on switch traffic and the size of the MSDL base software.

## Card enabling or application enabling

If a normal download enable command is executed, the MSDL base code and application is conditionally downloaded to the DDCH card. This conditional

download depends on the result of the check made by the CPU on the MSDL base code and application software.

If a forced download enable command is executed in LD 96, the MSDL base code and application are forced down to the DDCH card, even if the base and application software is already resident on the DDCH card. In order to complete a forced download, the following conditions must be met:

- the DDCH card must be enabled
- the D-channel port must be disabled

## Card reset

After a card reset, the MSDL base code and the D-channel application software are validated by the CPU. The software is stored in flash EPROM on the DDCH card and does not have to be downloaded. But if the software is missing due to new installation, corruption, or loadware version mismatch, the CPU automatically downloads the base/application into the DDCH card.

## Background audit

If a background audit of the card and associated applications finds that a download is required, the card is queued in the PSDL tree. Downloading is performed in background mode based on the entries in the PSDL tree.

---

# NTCK16 Generic Central Office Trunk cards

---

## Contents

This section contains information on the following topics:

Introduction . . . . .	791
Physical description . . . . .	793
Functional description . . . . .	793
Operation . . . . .	794
Electrical specifications . . . . .	796
Connector pin assignments . . . . .	797
Configuration . . . . .	797
Applications . . . . .	807

## Introduction

The NTCK16 generic Central Office trunk cards support up to eight analog Central Office trunks. They can be installed in any IPE slot.

The cards are available with or without the Periodic Pulse Metering (PPM) feature. The cards are also available in numerous countries. Country specific information is provided in this chapter.

The cards are identified by a two-letter suffix to the product code called the vintage. The card vintage is based on whether PPM is equipped or not, and the individual countries where the card is being installed.

The cards listed below are minimum vintage required to support the following countries:

- NTCK16AA generic Central Office trunk card with PPM
  - Ireland
- NTCK16BC generic Central Office trunk card without PPM.
  - Brazil
  - Ireland
  - Mexico
  - Tortolla
  - Singapore
- NTCK16AD generic Central Office trunk card with PPM
  - Turkey
- NTCK16BD generic Central Office trunk card without PPM.
  - Argentina
  - Turkey
  - Brazil
  - Chile
  - Indonesia
  - Korea
  - Venezuela

Throughout this chapter, cards with PPM will be identified by the vintage AX. Cards without PPM will be referenced by the vintage BX.



## Physical description

The NTCK16AX and NTCK16BX generic Central Office trunk cards have eight units. Each unit connects to the shelf backplane through an 80-pin connector. The backplane is cabled to the I/O panel which is then cabled to the cross-connect terminal. At the cross-connect terminal, each unit connects to external apparatus by Tip and Ring leads.

## Switch settings

There are no option switches on the NTCK16AX and NTCK16BX generic Central Office trunk cards. All settings are configured in software.

## Self-test

When the NTCK16AX and NTCK16BX trunk cards are installed and power is applied to them, a self-test is performed on each card. The red LED on the faceplate flashes three times, then remains continuously lit until the card is enabled in software. If the self-test fails, the LED remains lit.

## Functional description

The NTCK16AX and NTCK16BX generic Central Office trunk cards support up to eight analog Central Office trunks. They can be installed in any IPE slot.

Both cards are exactly the same except for the Periodic Pulse Metering (PPM) feature. The NTCK16AX card supports internal 12/16 kHz PPM but the NTCK16BX card does not.

## Common features

The NTCK16AX and NTCK16BX generic Central Office trunk cards:

- support the North American loss plan
- support loop start signalling
- support busy tone detection and supervision on a per unit basis.
- support battery reversal detection

- provide 4 dB dynamic attenuation pads on a per call basis
- allow individual units or the entire board to be disabled by software
- provide software selectable A-law or  $\mu$ -law companding
- indicate self-test status during an automatic or manual self-test
- provide card-identification for auto configuration, and for determining the serial number and firmware level of the card
- convert transmission signals from analog-to-digital and from digital-to-analog
- provide termination and trans-hybrid balance impedance to match 600  $\Omega$ .

## Operation

Each NTCK16AX and NTCK16BX generic Central Office trunk card supports the following:

- Loop start operation
- Battery reversal detection
- Busy tone detection and supervision
- Loss Switching
- Trunk-to-Trunk connections
- Call Disconnect

In addition, the NTCK16AX circuit card supports internal 12/16 kHz PPM detection.

### Loop start operation

Loop start operation is configured in software and is implemented in the card through software download messages.

### Idle state

In the idle state, the ringing detector is connected across the tip and ring wires, providing a high impedance loop toward the Central Office.

### **Call placed by Central Office**

The Central Office initiates a call by applying ringing between the tip and ring wires. If the call is answered, the ringing detector on the trunk card is switched out and a low resistance dc loop is placed between the tip and ring leads.

On trunks configured for battery supervision, the battery detector records the polarity of the tip and ring wires and sends an answer acknowledge signal to software.

### **Call placed by CS 1000S, CS 1000M, and Meridian 1**

To initiate a call, the CS 1000S, CS 1000M, and Meridian 1 switches out the ringing detector and places a low resistance loop across the tip and ring leads. On trunks configured for battery supervision, the trunk card sends a seize acknowledge signal to software.

The system sends digits in the form of Dual Tone Multifrequency (DTMF) tones or pulse digits. When the far-end answers, the Central Office reverses polarity. If the trunk is configured for battery supervision, it sends a polarity reversal message to software.

### **Central Office disconnect**

There are two ways the Central Office can disconnect the call:

- by applying busy tone toward the CS 1000S, CS 1000M, and Meridian 1. If the trunk card is configured to detect busy tone, it will send a disconnect message to software.
- by reversing battery. If the trunk card is configured to detect battery reversal, it will send a disconnect message to software. When the unit on the trunk card has been idled, the trunk card sends a release confirm message to software.

### **CS 1000S, CS 1000M, and Meridian 1 disconnect**

The CS 1000S, CS 1000M, and Meridian 1 disconnects the call by removing the loop between the tip and ring leads and replacing the ringing detector. Trunks configured for battery supervision send a release confirm message to software.

## Electrical specifications

### Power requirements

Table 256 shows the power requirements for the NTCK16AX and NTCK16BX generic Central Office trunk cards.

**Table 256**  
**NTCK16 circuit card power requirements**

Voltage	Idle Current	Active current
+15.0 V dc (See 1)	170 ma	330 ma
-15.0 V dc (See 1)	170 ma	249 ma
+8.5 V dc (See 2)	101 ma	100 ma
+5.0 V dc	160 ma	322 ma

*Note 1:* Analog circuitry is powered with +/-12 V generated from +/-15 V. The maximum current imbalance between the +/-15 V rails is 100 ma per circuit pack.

*Note 2:* 8.5V is regulated to give 5 V.

### Environmental specifications

Table 257 lists the environmental specifications of the NTCK16AX and NTCK16BX generic Central Office trunk cards.

**Table 257**  
**NTCK16 circuit card environmental specifications (Part 1 of 2)**

Parameter	Specifications
Operating temperature	10 to 45 degrees C
Operating humidity	20 to 80% RH (non-condensing)

**Table 257**  
**NTCK16 circuit card environmental specifications (Part 2 of 2)**

Parameter	Specifications
Storage temperature	-20 to +60 degrees C
Storage humidity	5 to 95% Relative Humidity

## Pad switching

The NTCK16AX and NTCK16BX generic Central Office trunk cards support the North American loss plan. Software configuration allows the selection of 4 dB loss pads on a per unit basis.

**Table 258**  
**NTCK16 pad switching**

Loss	Analog-to-Digital	Digital-to-Analog
PAD out	0 dB	-3 dB
PAD in	+4 dB	+1 dB

*Note:* The tolerance for the above nominal values is +0.3 dB, -0.7 dB.

## Connector pin assignments

### Cross connections

Figure 167 on [page 798](#), Figure 168 on [page 799](#), and Figure 169 on [page 800](#) provide cross connect information for the NTCK16AX and NTCK16BX generic Central Office trunk cards.

## Configuration

The trunk type for each unit on the card is selected by software service change entries at the system terminal.

**Figure 167**  
**NTCK16 Central Office trunk connections for NT8D37 I/O panel connectors A, E, K, R**

Lead designations	Pins	Pair Color	I/O Panel Connector				Unit Number
			A	E	K	R	
COT							
T0 R0	26 1	W-BL BL-W					Unit 0
	27 2	W-O O-W					
T1 R1	28 3	W-G G-W					Unit 1
	29 4	W-BR BR-W					
T2 R2	30 5	W-S S-W	S L	S L	S L	S L	Unit 2
	31 6	R-BL BL-R	O T	O T	O T	O T	
T3 R3	32 7	R-O O-R	0	4	8	12	Unit 3
	33 8	R-G G-R					
T4 R4	34 9	R-BR BR-R					Unit 4
	35 10	R-S S-R					
T5 R5	36 11	BK-BL BL-BK					Unit 5
	37 12	BK-O O-BK					
T6 R6	38 13	BK-G G-BK					Unit 6
	39 14	BK-BR BR-BK					
T7 R7	40 15	BK-S S-BK					Unit 7
	41 16	Y-BL BL-Y					

**Figure 168**  
**NTCK16 Central Office trunk connections for NT8D37 I/O panel connectors B, F, L, S**

Lead designations	P i n s	P a i r C o l o r	I / O P a n e l C o n n e c t o r				U n i t N u m b e r
			B	F	L	S	
COT							
T0 R0	26 1	W-BL BL-W					Unit 0
	27 2	W-O O-W					
T1 R1	28 3	W-G G-W					Unit 1
	29 4	W-BR BR-W					
T2 R2	30 5	W-S S-W	S L	S L	S L	S L	Unit 2
	31 6	R-BL BL-R	O T	O T	O T	O T	
T3 R3	32 7	R-O O-R	1	5	9	13	Unit 3
	33 8	R-G G-R					Unit 4
T4 R4	34 9	R-BR BR-R					Unit 5
	35 10	R-S S-R					Unit 6
T5 R5	36 11	BK-BL BL-BK					Unit 7
	37 12	BK-O O-BK					Unit 8
T6 R6	38 13	BK-G G-BK					Unit 9
	39 14	BK-BR BR-BK					Unit 10
T7 R7	40 15	BK-S S-BK					Unit 11
	41 16	Y-BL BL-Y					Unit 12
T0 R0	42 17	Y-O O-Y					Unit 13
	43 18	Y-G G-Y					Unit 14
T1 R1	44 19	Y-BR BR-Y	S L	S L	S L	S L	Unit 15
	45 20	Y-S S-Y	O T	O T	O T	O T	Unit 16
T2 R2	46 21	V-BL BL-V					Unit 17
	47 22	V-O O-V	2	6	10	14	Unit 18
T3 R3	48 23	V-G G-V					Unit 19
	49 24	V-BR BR-V					Unit 20

**Figure 169**  
**NTCK16 Central Office trunk connections for NT8D37 I/O panel connectors C, G, M, T**

Lead designations	P i n s	P a i r C o l o r	I / O P a n e l C o n n e c t o r				U n i t N u m b e r
			C	G	M	T	
COT							
T4 R4	26 1	W-BL BL-W					Unit 4
	27 2	W-O O-W					
T5 R5	28 3	W-G G-W	S	S	S	S	Unit 5
	29 4	W-BR BR-W	L O	L O	L O	L O	
T6 R6	30 5	W-S S-W	T	T	T	T	Unit 6
	31 6	R-BL BL-R	2	6	10	14	
T7 R7	32 7	R-O O-R					Unit 7
	33 8	R-G G-R					
T0 R0	34 9	R-BR BR-R					Unit 0
	35 10	R-S S-R					
T1 R1	36 11	BK-BL BL-BK					Unit 1
	37 12	BK-O O-BK					
T2 R2	38 13	BK-G G-BK					Unit 2
	39 14	BK-BR BR-BK					
T3 R3	40 15	BK-S S-BK	S	S	S	S	Unit 3
	41 16	Y-BL BL-Y	L O	L O	L O	L O	
T4 R4	42 17	Y-O O-Y	T	T	T	T	Unit 4
	43 18	Y-G G-Y	3	7	11	15	
T5 R5	44 19	Y-BR BR-Y					Unit 5
	45 20	Y-S S-Y					
T6 R6	46 21	V-BL BL-V					Unit 6
	47 22	V-O O-V					
T7 R7	48 23	V-G G-V					Unit 7
	49 24	V-BR BR-V					



## NTCK16AX Central Office trunk card

### Route Data Block

Respond to the prompts in LD 16 as shown.

#### LD 16 – Route Data Block for NTCK16AX.

Prompt	Response	Description
REQ:	NEW	Define a new unit
TYPE:	COT	Define a new Route Data Block
CUST	xx	Customer number as defined in LD 15.
ROUT		Route number
	0-511	Range for Large System, Call Server 1000E, and Media Gateway 1000E
	0-127	Range for Small System, CS 1000S system, Media Gateway 1000B, and Media Gateway 1000T
TKTP	COT	Define trunk type as Central Office
ICOG	IAO	Incoming and Outgoing trunk
CNTL	YES	Change a trunk timer
TIMER	RGV 256	Set Ring Validation Timer to 128 ms.
MR	(NO) PPM XLD	PPM is off, buffered, or unbuffered on this route.

**Trunk Data Block**

Respond to the prompts in LD 14 as shown:

**LD 14 – Trunk Data Block for NTCK16AX. (Part 1 of 2)**

Prompt	Response	Description
REQ:	NEW	Define a new trunk unit
TYPE:	COT	Central Office Trunk
TN		Terminal Number
	l s c u	Format for Large System, Call Server 1000E, and Media Gateway 1000E, where l = loop, s = shelf, c = card, u = unit
XTRK (See note on <a href="#">page 803.</a> )	XCOT	Type is IPE COT
CDEN	(8D)	Card density is 8D (default)
SIGL	LOP	Loop start signaling
PPID (See <a href="#">page 803.</a> )	Xx	04 Ireland/Turkey 12 KHz 03 Turkey 16 KHz
BTID (See <a href="#">page 803.</a> )	Xx	Enter the country busy tone ID:  Tortola, Brazil = 10 Mexico = 10 or 08 (depending on CO) Singapore = 11 Ireland = 3 or 9 (depending on CO) Chile, Venezuela, Thailand, Korea = 06. Argentina = 12 or 07, Turkey = 14
SUPN	(NO) YES	Supervision yes (no)
STYP	BTS	Busy tone supervision enabled
	BAT	Loop break supervision enabled

**LD 14 – Trunk Data Block for NTCK16AX. (Part 2 of 2)**

Prompt	Response	Description
CLS	(LOL) SHL	Attenuation Pads In, (Out)
	DTN, (DIP)	Digitone signaling, (digipulse)
	P20, P12, (P10)	Make-break ratio for pulse dialing speed.

*Note:* These prompts are required only for the first unit defined on each NTCK16AX card.

PPIDFreqMin pulse detection

03 16Kz>70ms

04 12Kz>70ms

CountryBTIDCadence

Brazil, Tortola10250 ms +/- 50 ms on/off

Mexico10250 ms +/- 50 ms on/off

Mexico 8375 ms on/off

Singapore11750 ms on/off

Ireland 3500 +/- 50 ms on/off

Ireland 9375 - 750 ms on/off

Kuwait, Chile 6500 +/- 50 ms on/off

Venezuela, Indonesia12300 ms on, 200 ms off

Thailand, Korea12300 ms on, 200 ms off

Argentina12300 ms on, 200 ms off

Argentina07250 - 500 ms on/off

Turkey1410 seconds of Tone 1:

200 ms off, 200 ms on; 200 ms off,

200 ms on; 200 ms off, 200 ms on;

200 ms off, 600 ms on; followed by

Tone 2: 200 ms off, 200 ms on.

## NTCK16BX Central Office trunk card

### Route Data Block

Respond to the prompts in LD 16 as shown:

**LD 16** – Route Data Block for NTCK16BX.

Prompt	Response	Description
REQ:	NEW	Define a new unit.
TYPE:	COT	Define a new Route Data Block.
CUST	xx	Customer number as defined in LD 15.
ROUT		Route number
	0-511	Range for Large System, Call Server 1000E, and Media Gateway 1000E
	0-127	Range for Small System, CS 1000S system, Media Gateway 1000B, and Media Gateway 1000T
TKTP	COT	Define trunk type as Central Office.
ICOG	IAO	Incoming and Outgoing trunk
CNTL	YES	Change a trunk timer.
TIMER	RGV 256	Set Ring Validation Timer to 128 ms.
MR	(NO)	PPM is off on this route.

**Trunk Data Block**

Respond to the prompts in LD 14 as shown:

**LD 14 – Trunk Data Block for NTCK16BX. (Part 1 of 2)**

Prompt	Response	Description
REQ:	NEW	Define a new trunk unit.
TYPE:	COT	Central Office Trunk
TN		Terminal Number
	l s c u	Format for Large System, Call Server 1000E, and Media Gateway 1000E, where l = loop, s = shelf, c = card, u = unit
XTRK (See note 1 on <a href="#">page 806.</a> )	XCOT	Type is IPE COT
CDEN	(8D)	Card density is 8D (default).
SIGL	LOP	Loop start signaling
BTID (See <a href="#">page 807.</a> )	Xx	Enter the country busy tone ID:  Tortola, Brazil = 10 Mexico = 10 or 08 (depending on CO) Singapore = 11 Ireland = 3 or 9 (depending on CO) Kuwait, Chile, Venezuela, Indonesia, Thailand, Korea = 06. Argentina = 12 or 07, Turkey = 14
SUPN	(NO) YES	Supervision yes (no)
STYP	BTS	Busy tone supervision enabled
	BAT	Loop break supervision enabled
CLS	(LOL) SHL	Attenuation Pads In, (Out)

**LD 14 – Trunk Data Block for NTCK16BX. (Part 2 of 2)**

Prompt	Response	Description
	(DIP) DTN	Digitone signaling, (digipulse)
	(P10) P12 P20	Make-break ratio for pulse dialing speed.

*Note 1:* These prompts are required only for the first unit defined on each NTCK16BX card.

**BTID values by country**Country BTID Cadence

Brazil Tortola 10 250 ms +/- 50 ms on/off

Mexico 8 375 ms on/off

Mexico 11 750 ms on/off

Singapore 3 500 +/- 50 ms on/off

Ireland 9 375 - 750 ms on/off

Kuwait, Chile 6500 +/- 50 ms on/off

Venezuela, Indonesia 12300 ms on, 200 ms off

Thailand, Korea 12300 ms on, 200 ms off

Argentina 12 300 ms on, 200 ms off

Argentina 07 250 - 500 ms on/off

Turkey 14 10 seconds of Tone 1:

200 ms off, 200 ms on; 200 ms off,  
200 ms on; 200 ms off, 200 ms on;  
200 ms off, 600 ms on; followed by  
Tone 2: 200 ms off, 200 ms on.

**Applications****Periodic Pulse Metering**

All trunk units on the NTCK16AX trunk card can be individually configured to support the Periodic Pulse Metering (PPM) feature.

*Note:* PPM is available on the NTCK16AX trunk card. It is not supported on the NTCK16BX trunk card.

PPM allows the user of a telephone to keep an accurate record of Central Office calls for billing or administration purposes.

### Detection limits

Pulses detected by the NTCK16AX circuit card must be within the following limits:

Frequency	11 880 to 12 120 Hz
Level	105 to 1100 mVrms  <b>Note:</b> The pack should not be used to detect levels of 1100 mVrms or greater a Tip and Ring, as this may result in noise.
Pulse length	Dependent on PPID – see LD 14

### Busy tone detect

Busy tone is sent by the Central Office to indicate the release of an established call.

#### Detection limits

The NTCK16AX and NTCK16BX generic Central Office trunk cards can detect busy tone within the following limits:

<b>Frequency</b>	<b>400 to 620 Hz</b>
Level	-30 to 0 dBm
Cadence	See on <a href="#">page 803</a> .

### Loss switching

The Generic XFCOT is based on the XFCOT design, which is using a static pad download algorithm by default for its loss plan.

The generic XFCOT has to be set explicitly to a Dynamic Pad Switching mode to make it compliant with the standard North American Dynamic Pad Switching mode.



Therefore the following steps must be followed when the Generic XFCOT is installed:

- 1 Define Loss Switching mode. Respond to the prompts in LD 97 as shown.

**LD 97 – Defining Loss Switching mode.**

Prompt	Response	Description
REQ:	CHG	IPE system parameters configuration
TYPE:	SYSP	
...		
NATP	YES	
		Select North American transmission plan. <b>Note:</b> The default to the NATP prompt is NO, and therefore this prompt must always be checked during installation.

- 2 Define Loss Switching Class Of Service. Respond to the prompts in LD 14 as shown.

**LD 14 – Defining Loss Switching Class Of Service.**

Prompt	Response	Description
REQ:	CHG	LOL= Long Line <b>Note:</b> The XFCOT uses the CLS Long Line (LOL) and Short Line (SHL) for Loss Switching purposes and that the card and trunk type is different from the XUT.
TYPE:	COT	
XTRK	XCOT	
SIGL	LOP	
...		
CLS	LOL	

### **Equivalencies**

The following equivalencies do apply:

- XFCOT COT SHL is equivalent with XUT COT TRC
- XFCOT COT LOL is equivalent with XUT COT NTC.

The entries TRC and NTC will no longer be allowed for the Generic XFCOT.

### **Trunk to Trunk connection**

When any disconnect supervision is configured (CLS = BAT, BTS) the Loop Start Trunk of the Generic XFCOT will be marked as having disconnect supervision and will therefore follow the same rules as a Ground Start Trunk.

There is no configuration involved for this operation.

### **Call disconnect**

When any disconnect supervision is configured (CLS = BAT, BTS) the Loop Start Trunk will be released when the disconnect signal is received. This will apply also in call states such as ringing, camp-on, DISA, and Meridian Mail.

There is no configuration involved for this operation.

---

# NTDK20 Small System Controller card

---

## Contents

This section contains information on the following topics:

<a href="#">Introduction</a> . . . . .	811
<a href="#">Memory</a> . . . . .	814
<a href="#">100BaseT IP daughterboards</a> . . . . .	815
<a href="#">PC card interface</a> . . . . .	818
<a href="#">Security device</a> . . . . .	819
<a href="#">SDI ports</a> . . . . .	820
<a href="#">Conferencing</a> . . . . .	820
<a href="#">MG 1000S/Expansion card slot assignment</a> . . . . .	821

## Introduction

This chapter introduces the NTDK20GA Small System Controller (SSC) Card used in the Call Server, MG 1000S, and Media Gateway 1000B (MG 1000B). It controls call processing, stores system and customer data, and provides various 100BaseT IP interfaces.

You can install this card in slots 1 through 4 in the MG 1000S or slots 7 through 10 in the MG 1000S Expansion

The NTDK20FA SSC card is the minimum vintage of SSC that can be used in the Call Server and MG 1000S. See Figure 170 on [page 813](#).

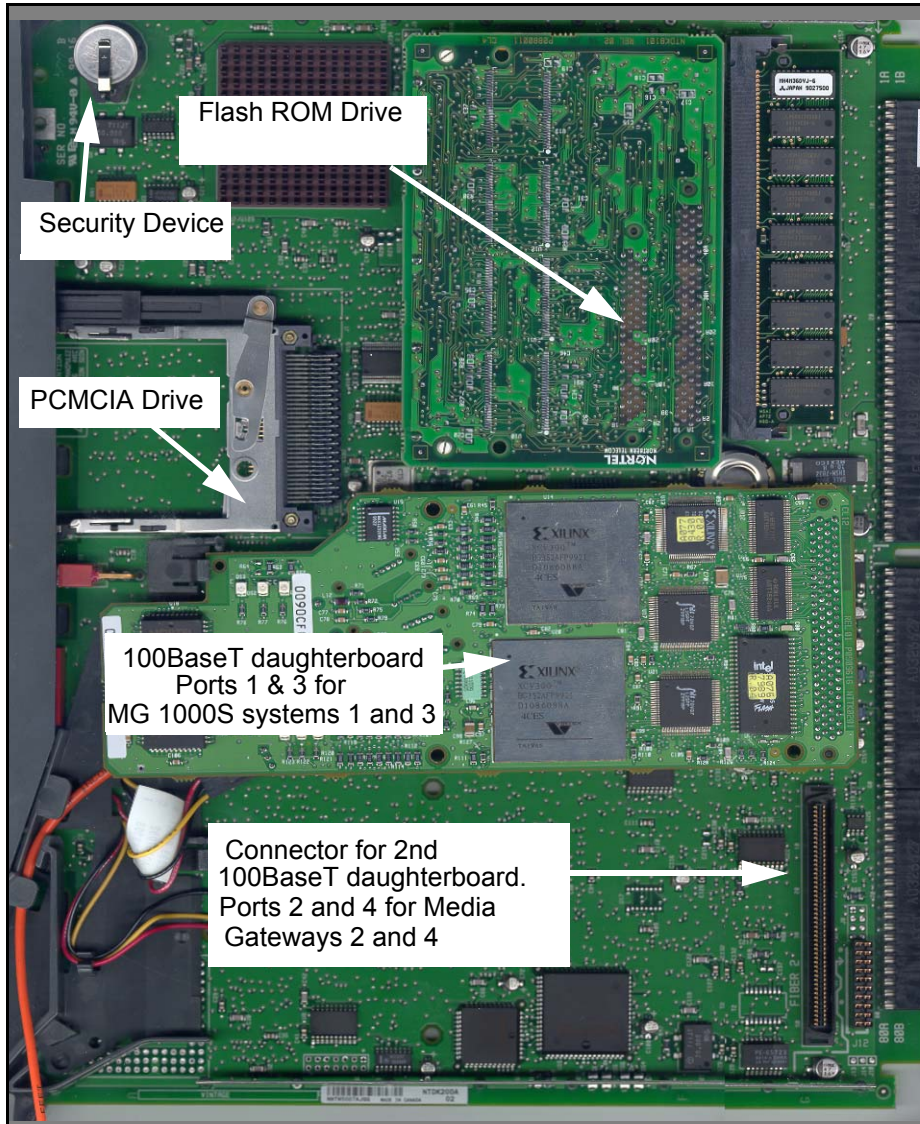
The NTDK20GA SSC card has the following components and features:

- NTKK25 daughterboard Flash memory, NTAK19 SIMM module (16 MB) DRAM, and Backup memory

*Note:* The NTKK13 daughterboard is still supported.

- up to two 100BaseT IP daughterboards
- two PCMCIA sockets
- three Serial Data Interface (SDI) ports
- 32 channels of Conferencing (64 if one dual-port 100BaseT IP daughterboard is present, or 96 if two dual-port 100BaseT IP daughterboards are present)
- one 10BaseT port
- 30 channels of Tone and Digit Switch (TDS) and a combination of eight Digitone Receivers (DTR) or Extended Tone Detectors (XTD)
- additional tone service ports (four units of MFC/MFE/MFK5/MFK6/MFR or eight DTR/XTD units)

Figure 170  
NTDK20 SSC card and expansion daughterboard in the Call Server



## Memory

The majority of system and customer configured data is both controlled and stored on the NTDK20 SSC card's Flash ROM. An active and backup copy of customer data is also kept on the Flash ROM.

In the event of data loss, the NTDK20 SSC card also retains a copy of customer files in an area called the Backup flash drive. The NTDK20 SSC card is equipped with 8MB of temporary memory space called DRAM. DRAM functions much like RAM on a computer system. It stores and processes temporary automated routines and user-programmed commands while the system is running. The DRAM on the SSC card stores operating system files, user files, overlay data, patch codes, and the active copy of the customer database.

The NTDK20 SSC card's Flash daughterboard is the NTTK25. It performs most of the system software storage and data processing.

### NTTK25 daughterboard

The NTTK25 is a 48 MB daughterboard comprised of Flash ROM and Primary Flash drive. It is required in the Call Server and MG 1000S.

The Flash ROM holds 32 MB of ROM memory, comprising operating system data and overlay programs. Flash ROM is expandable using an expansion flash daughterboard.

The Primary Flash drive contains 16 MB of storage space. Most of the data storage is allocated to the Primary Flash drive – the main storage area of customer configured data.

Other system data such as the Secure Storage Area (SSA) also resides in the Flash drive. The SSA holds data that must survive power interruptions.

The Boot ROM is a 2 MB storage device located on the NTDK20 SSC card. The Boot ROM contains the boot code, system data, patch data, and the backup copy of the Primary Flash drive's customer database.

## 100BaseT IP daughterboards

A 100BaseT IP Daughterboard mounted on the NTDK20 SSC card enables the connection of the Call Server to a MG 1000S. See Figure 170 on [page 813](#).

Each daughterboard increases the number of conference channels by 32. The maximum number of conference ports is 96. Table 259 on [page 817](#) provides the ports, cables, and connection data on the IP daughterboards.

The NTDK83 (dual-port) 100BaseT IP daughterboard mounts on the NTDK20 SSC card in the Call Server. It provides connectivity to two MG 1000S systems and their associated MG 1000S Expansions.

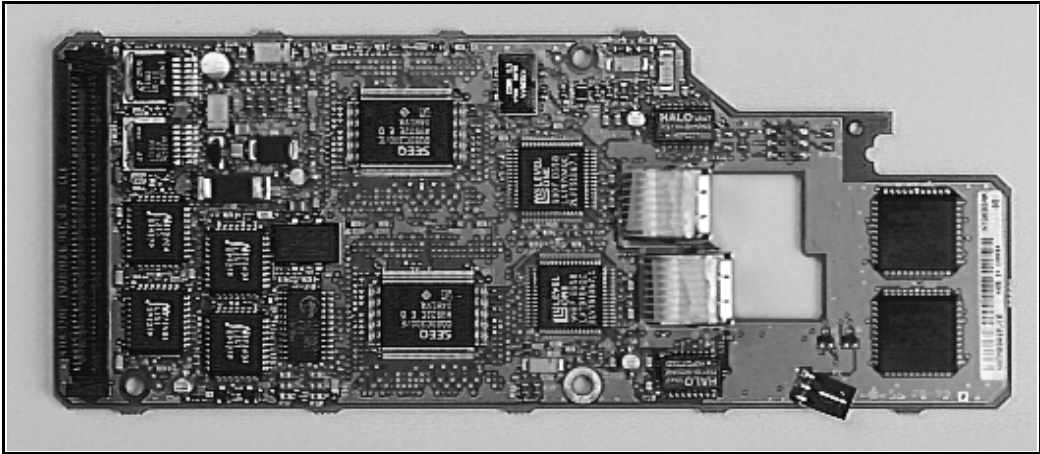
**Note:** With a point-to-point connection, the MG 1000S must be within 100 meters of the Call Server.

An optional second NTDK83 daughterboard can be mounted on the NTDK20 SSC card in the Call Server. Adding the second NTDK83 daughterboard provides support for up to four MG 1000S systems. See Figure 171 on [page 816](#).

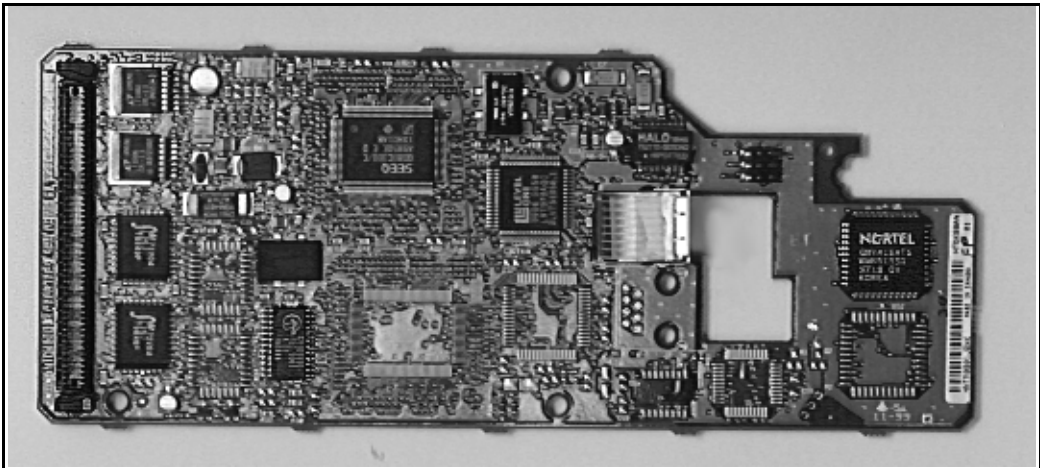
The NTDK99AA (single-port) daughterboard is mounted on the NTDK20 SSC card in the MG 1000S to provide connectivity to the Call Server. See Figure 172 on [page 816](#).

**Note:** Third party media conversion devices can be used to extend the range of MG 1000S systems from the Call Server. The IMC Networks Ethernet Compatible Media Converter with a McLIM Tx/Fx-SM/Plus module was tested by Nortel. It provided acceptable transmission between the Call Server and the MG 1000S located up to 40 kms apart.

**Figure 171**  
**NTDK83AA dual-port 100BaseT IP daughterboard**



**Figure 172**  
**NTDK99A single-port 100BaseT IP daughterboard**





**Table 259**  
**Expansion daughterboards**

Daughterboard	Number of ports	Cable type	Max. distance between Call Server and MG 1000S systems
NTDK99 (used in MG 1000S)	one	Use the supplied NTTK34AA UTP CAT 5 RJ-45 2 m cross-over cable to connect the Call Server and MG 1000S using the 100BaseT daughterboards.  The NTTK34AA cross-over cable must be used if connecting point-to-point.	MG 1000S systems can be located up to 100 m (328 ft.) from the Call Server if connected point-to-point, or up to 40 km (24 miles) from the Call Server if a third party converter is used to convert to fiber.
NTDK83 (used in Call Server)	two		

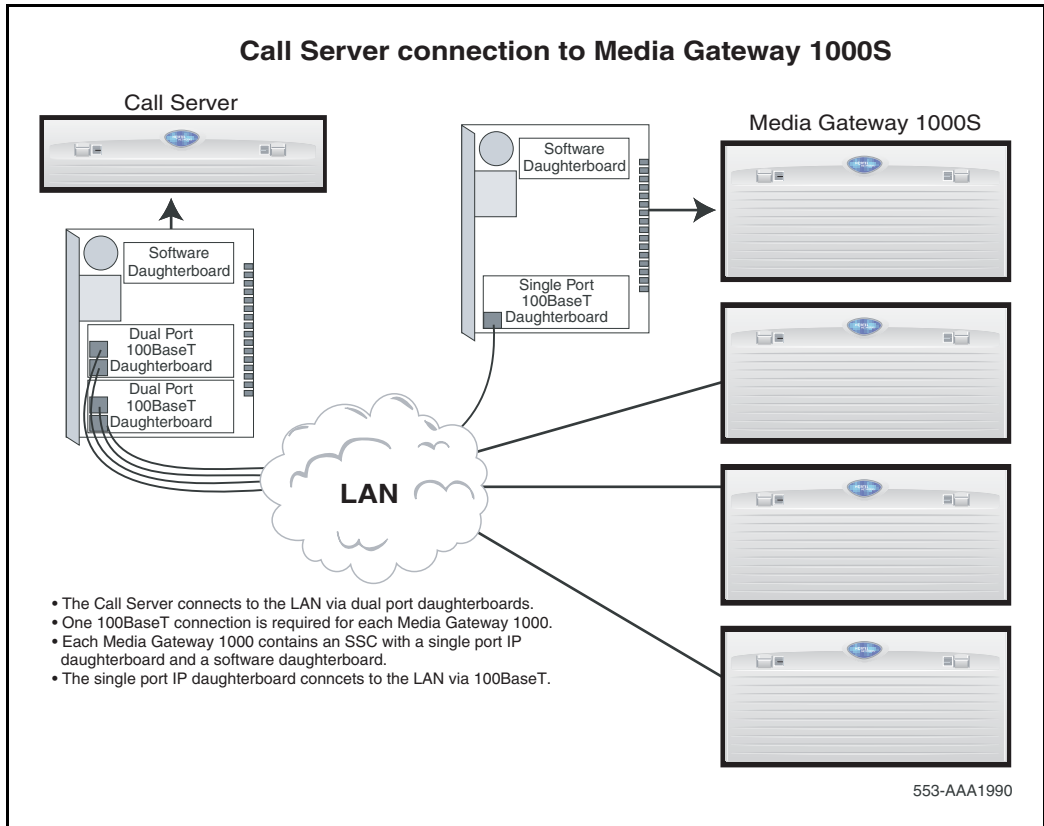
**Note:** If not connecting point-to-point, connect the Call Server and MG 1000S using a straight-through Ethernet UTP Cat 5 cable.

Call Servers can be connected to MG 1000S systems in the following ways:

- Use 100BaseT to connect to the LAN for voice distribution over a data network.
- Use 100BaseT cable if connected point-to-point (directly) to the MG 1000S. The NTTK34AA crossover cable must be used. MG 1000S systems can be located up to 100 meters from the Call Server.
- Use Media Conversion devices (third party converters) to convert 100BaseT to fiber for distances from 100 m to 40 km.

See Figure 173 on [page 818](#).

**Figure 173**  
**Call Server connection to Media Gateway 1000S systems**



For further information or installation instructions, refer to the *Communication Server 1000S: Installation and Configuration* (553-3031-210).

## PC card interface

The NTDK20 SSC card has a PC card interface through a socket located on its faceplate. The PC card socket can accommodate a Software Delivery card used for software upgrading and as backup media.

## Security device

The NTDK20 SSC card in each MG 1000S must contain a NTDK57DA Security device, a remote dongle (NT\_Rem) which is keyed to match the NTDK57AA Security device on the Call Server and a standard dongle (NT\_STD). This maintains the requirement of a single keycode for each system. Refer to Figure 170 on [page 813](#) for the location of the device.

This security scheme provides the following:

- enables the system to operate as a single system when all links are up.
- enables the MG 1000S to continue operating with its existing configuration in the event of a failure of the Call Server, or the failure of the link to the Call Server from the MG 1000S.
- prevents users from configuring or using unauthorized TNs or features.

The MG 1000S security device provides the following capabilities for the MG 1000S:

- System software can be installed but no calls can be processed or features activated until communication with the Call Server has been established and a match between the security ID of the Call Server and the MG 1000S has been confirmed.
- System software can be upgraded.

**Note:** Local data dump, LD 43 commands, and LD 143 commands are not permitted.

## SDI ports

The NTDK20 SSC card in both the Call Server and the MG 1000S systems contains three SDI ports used to connect on-site terminals or remote terminals through a modem. Table 260 shows the port default settings.

**Table 260**  
**Default SDI port settings on the NTDK20 SSC card**

TTY Port	Baud rate	Data bits	Stop bits	Parity	Use
0	Set by a DIP switch	8	1	None	MTC/SCH/BUG
1	1200	8	1	None	MTC/SCH/BUG
2	1200	8	1	None	MTC/SCH/BUG

## Conferencing

Thirty-two conference channels are provided by the NTDK20 SSC card's conference devices. Conference capability can be increased by mounting expansion daughterboards on the NTDK20 SSC card. Each dual IP daughterboard increases the total number of conference channels by 32. The maximum number of conference ports is 96.

Each conference device provides 32 ports of conferencing capabilities (one conference participant for each port). A conference call can have three to six participants. For example, there could be six 5-party conferences on each device, or four 6-party conferences plus two 3-party conferences. It is not possible to conference between conference devices.

### 10BaseT port

The Call Server provides one 10BaseT connection to a Local Area Network (LAN) to interface with Management software applications such as OTM and CallPilot. The MG 1000S SSC 10BaseT port, Port 1, is disabled by default. To use the 10BaseT port, the port must be assigned a unique IP address and the port must be enabled from the Call Server.

The MG 1000S 10BaseT port can run in Normal mode or Survival mode. In Normal mode, the MG 1000S does not provide access to maintenance or alarm management.

External connections to the 10BaseT port are provided by a 15-pin connector located on the backplanes of the Call Server and MG 1000S systems.

## **MG 1000S/Expansion card slot assignment**

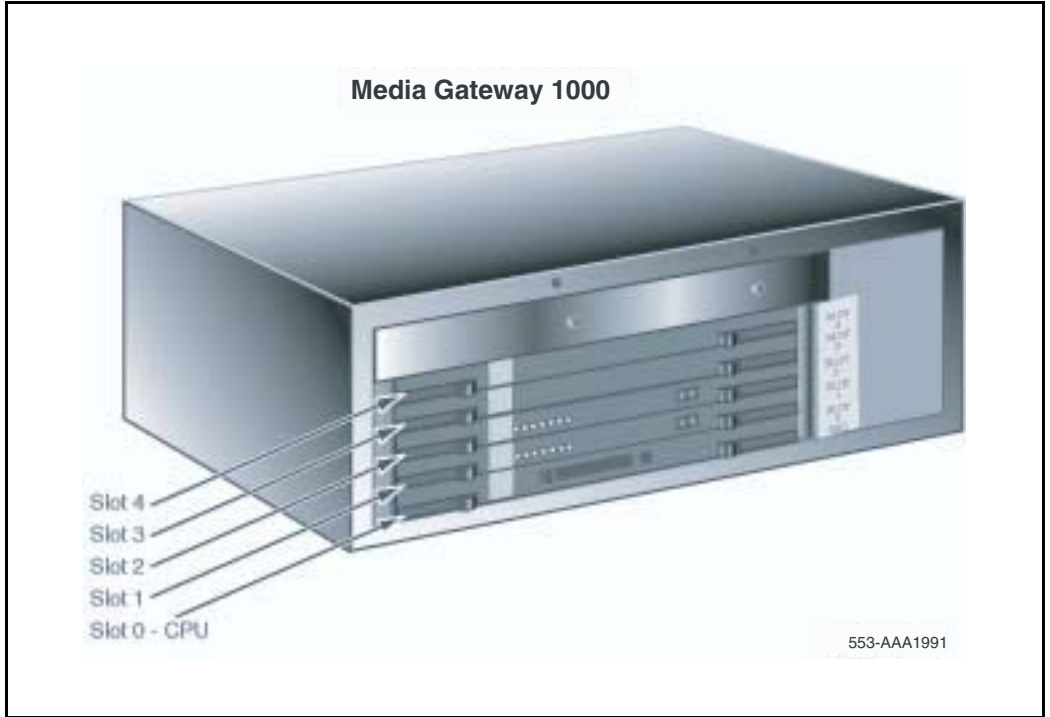
The MG 1000S and MG 1000S Expansion contain physical card slots, numbered 1 to 10. See Figure 174 on [page 823](#) and Figure 175 on [page 824](#).

When configuring the system, the physical card slot numbers must be transposed to “logical” card slot numbers. For example, to configure a card physically located in Slot 2 of the first MG 1000S, use logical Slot 12. To configure a card physically located in Slot 2 of the second MG 1000S, use logical Slot 22. See Table 261 on [page 822](#).

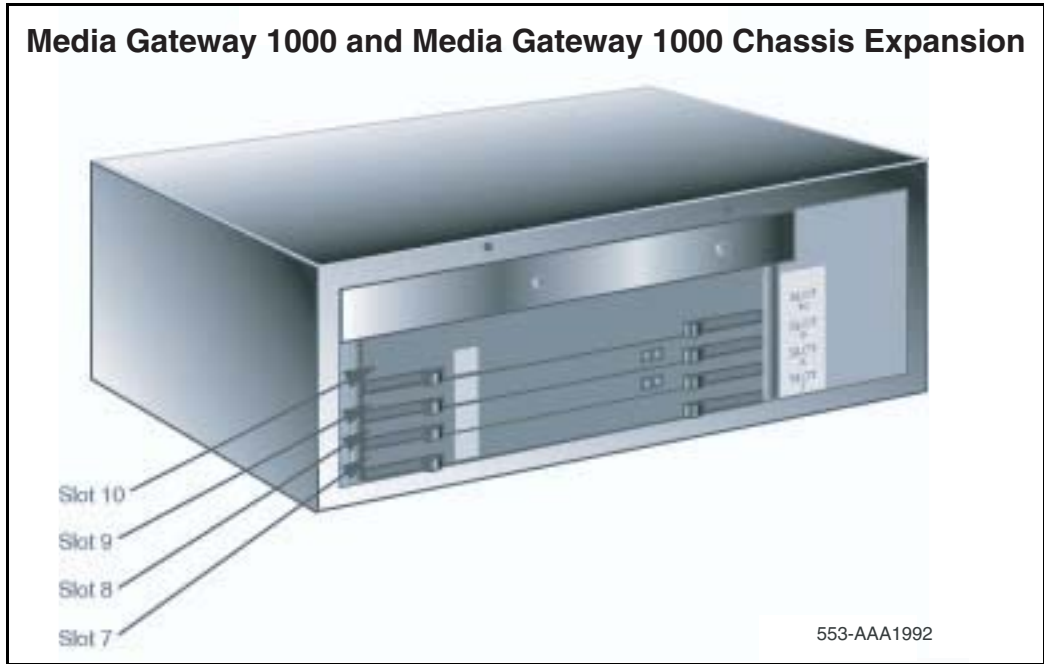
**Table 261**  
**MG 1000S and MG 1000S Expansion slot assignments**

		MG 1000S/MG 1000S Expansion							
		First		Second		Third		Fourth	
		Physical card slot	Logical card slot	Physical card slot	Logical card slot	Physical card slot	Logical card slot	Physical card slot	Logical card slot
MG 1000S	1	11	1	21	1	31	1	41	
	2	12	2	22	2	32	2	42	
	3	13	3	23	3	33	3	43	
	4	14	4	24	4	34	4	44	
	5	*	5	*	5	*	5	*	
	6	*	6	*	6	*	6	*	
MG 1000S/ Expansion	7	17	7	27	7	37	7	47	
	8	18	8	28	8	38	8	48	
	9	19	9	29	9	39	9	49	
	10	20	10	30	10	40	10	50	
<b>Legend</b> * Not supported.									

Figure 174  
MG 1000S slots



**Figure 175**  
**MG 1000S Expansion slots**





---

# NTRB21 DTI/PRI/DCH TMDI card

---

## Contents

This section contains information on the following topics:

Introduction . . . . .	825
Physical description . . . . .	826
Functional description . . . . .	830
Software description . . . . .	831
Hardware description . . . . .	831
Architecture . . . . .	831

## Introduction

The NTRB21 (DTI/PRI/DCH) TMDI digital trunk card is a 1.5 Mb DTI or PRI interface to the CS 1000S, CS 1000M Cabinet, and Meridian 1 PBX 11C Cabinet. The NTRB21 card has a built-in downloadable D-channel.

The TMDI feature supports the software changes required for CS 1000S, CS 1000M Cabinet, and Meridian 1 PBX 11C Cabinet to use the new TMDI pack. The software changes include:

- a new prompt to replace a function that was handled by a dip switch on the NTAK09
- an extra loadware application to handle Layer 1
- a change to the existing loadware files into 32 bit format from the original 16 bit format

To provide CEMUX communication with the card, changes are also required to create an I/O entry for the card.

You can install this card in slots 1 through 4 in the MG 1000S. The card is not supported in the MG 1000S Expansion. Up to four digital trunks are supported in each MG 1000S.

*Note 1:* For CISPR B group cabinets, the active Clock Controller (NTAK20) can only occupy slots 1-3. For FCC and/or CISPR A group cabinets, this limitation does not exist - the Clock Controller can occupy any available slot 1-9.

*Note 2:* On non-ECM system cabinets, the NTAK20 may be placed in slots 1-9. On cabinets NTAK11Dx and NTAK11Fx, the active NTAK20 must be placed in slots 1-3 (slots 4-10 may not be used).

**IMPORTANT!**

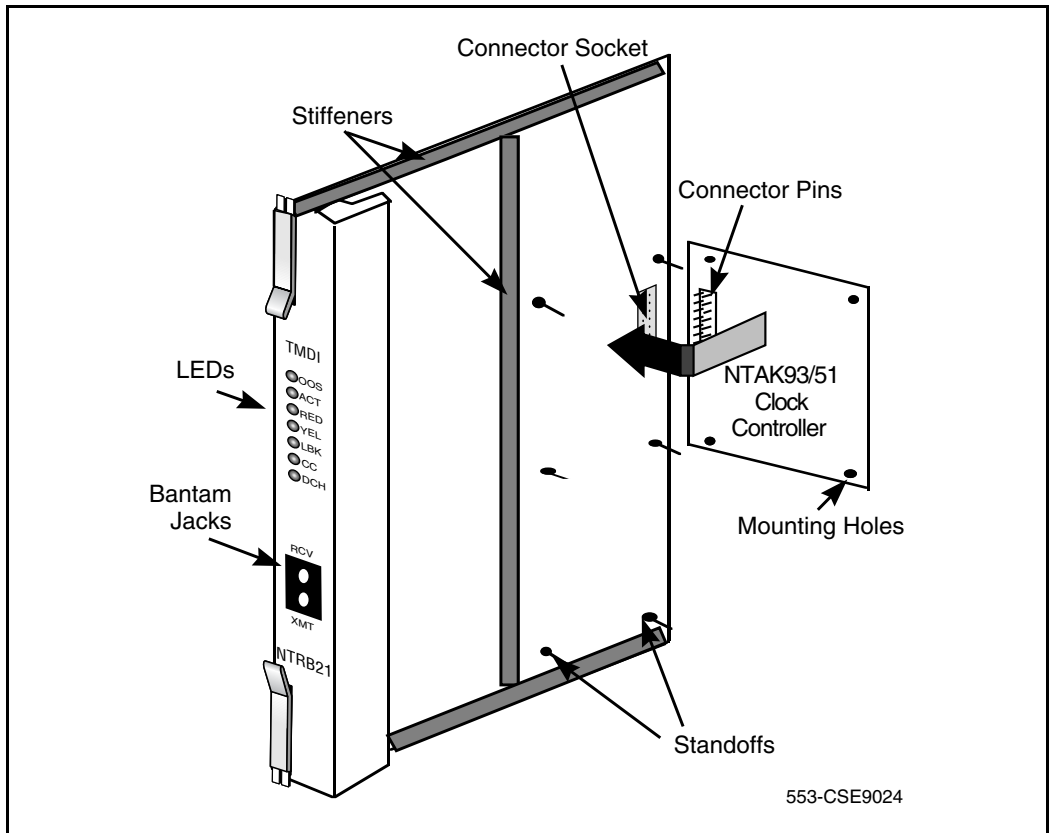
Each MG 1000S that has a digital trunk **must** have a clock controller clocked to an external reference clock.

## Physical description

The NTRB21 card uses a standard 9.5" by 12.5" multi-layer printed circuit board with buried power and ground layers. The clock controller daughterboard is fastened by standoffs and connectors.

The NTRB21 card has seven faceplate LEDs. The first five LEDs are associated with the NTRB21 card. The remaining two LEDs are associated with the clock controller and DCHI daughterboards. See Figure 176.

Figure 176  
NTRB21 TMDI card with clock controller



In general, the first five LEDs operate as follows:

- During system power up, the LEDs are on.
- When the self-test is in progress, the LEDs flash on and off three times, then go into their appropriate states, as shown in Table 262.

**Table 262**  
**NTRB21 LED states**

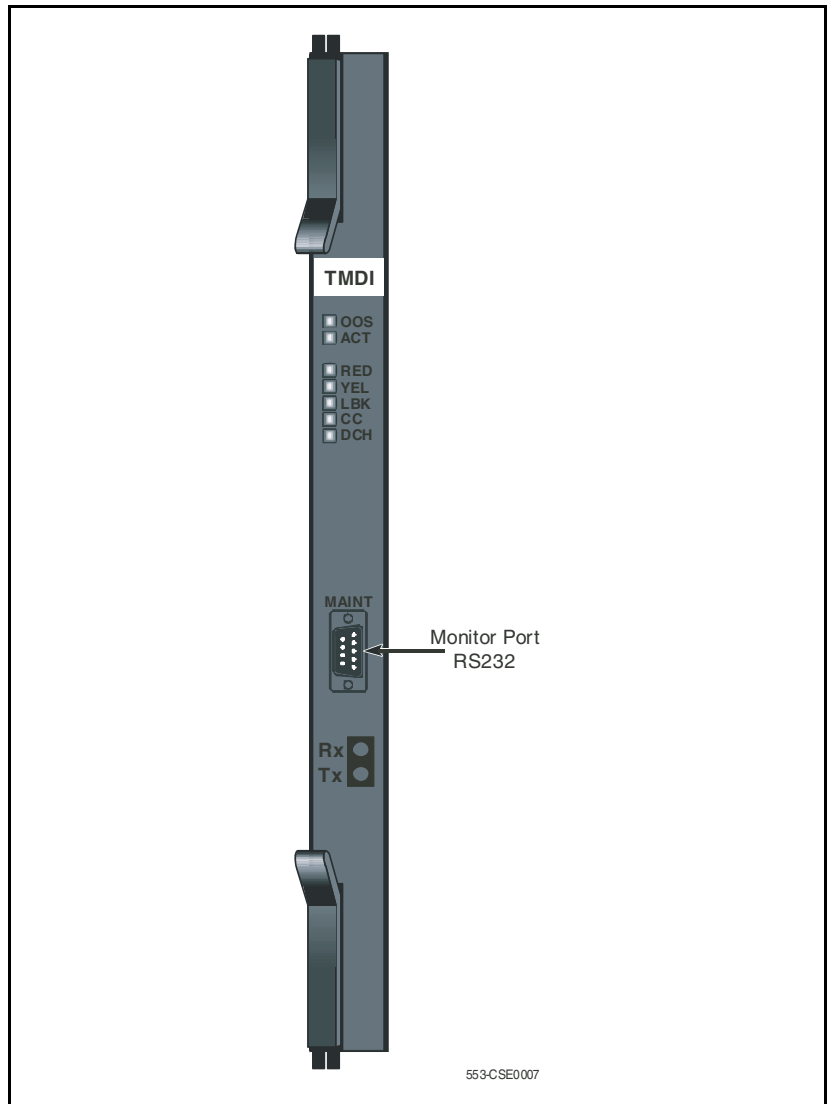
LED	State	Definition
<b>DIS</b>	On (Red)	The NTRB21 circuit card is disabled.
	Off	The NTRB21 is not in a disabled state.
<b>ACT</b>	On (Green)	The NTRB21 circuit card is in an active state. No alarm states exist, the card is not disabled, nor is it in a loopback state.
	Off	An alarm state or loopback state exists, or the card has been disabled. See the other faceplate LEDs for more information.
<b>RED</b>	On (Red)	A red-alarm state has been detected.
	Off	No red alarm.
<b>YEL</b>	On (Yellow)	A yellow alarm state has been detected.
	Off	No yellow alarm.
<b>LBK</b>	On (Green)	NTRB21 is in loop-back mode.
	Off	NTRB21 is not in loop-back mode.

Figure 177 on [page 829](#) shows the faceplate of the NTRB21 TMDI card.

## Power requirements

The DTI/PRI obtains its power from the backplane, and draws less than 2 amp on +5 V, 50 mA on +12 V, and 50 mA on -12 V.

**Figure 177**  
**NTRB21 TMDI card faceplate**



## Foreign and surge voltage protection

Lightning protectors must be installed between an external T1 carrier facility and the system. For public T1 facilities, this protection is provided by the local operating company. In a private T1 facility environment (a campus, for example), the NTA92 protection assembly can be used.

The NTRB21 circuit card conforms to safety and performance standards for foreign and surge voltage protection in an internal environment.

## Functional description

NTRB21 provides the following features and functions:

- configurable parameters, including A-Law and  $\mu$ -Law operation, digital pads on a per channel basis, and Superframe or Extended Superframe formats
- AMI or B8ZS line coding
- 1.5 Mb Digital Trunk Interface and 1.5 Mb Primary Rate Interface
- 1.5 Mb Clock recovery and distribution of reference clocks
- DG2 or FDL yellow alarm methods
- card status and alarm indication with faceplate-mounted LED
- automatic alarm monitoring and handling
- Card-LAN for maintenance communication
- loopback capabilities for both near-end and far-end
- echo canceler interface
- integrated trunk access (both D-channel and in-band A/B signaling can be mixed on the same PRI)
- faceplate monitor jacks for T1 interface
- configurable D-channel data rate with 64 kbps, 56 kbps or 64 kbps inverted
- self-test

## Software description

Changes from the NTAK09 are required for the new trunk card and License parameters are n service change and maintenance overlays. There is a change to CardLAN to introduce a new CardLAN ID. The download of PSDL data is also changed to handle a 32 bit download as well as existing 16 bit.

## Hardware description

### NTRB21 TMDI card

The NTRB21 TMDI card provides 1.5 MBits Digital Trunk Interface or Primary Rate Interface functionality. It also has a built-in downloadable D-channel.

The NTRB21 can be used with the NTAK09 DTI/PRI card (with the NTBK51 downloadable D-channel daughterboard).

Figure 178 on [page 832](#) shows a faceplate of the NTRB21 TMDI card.

## Architecture

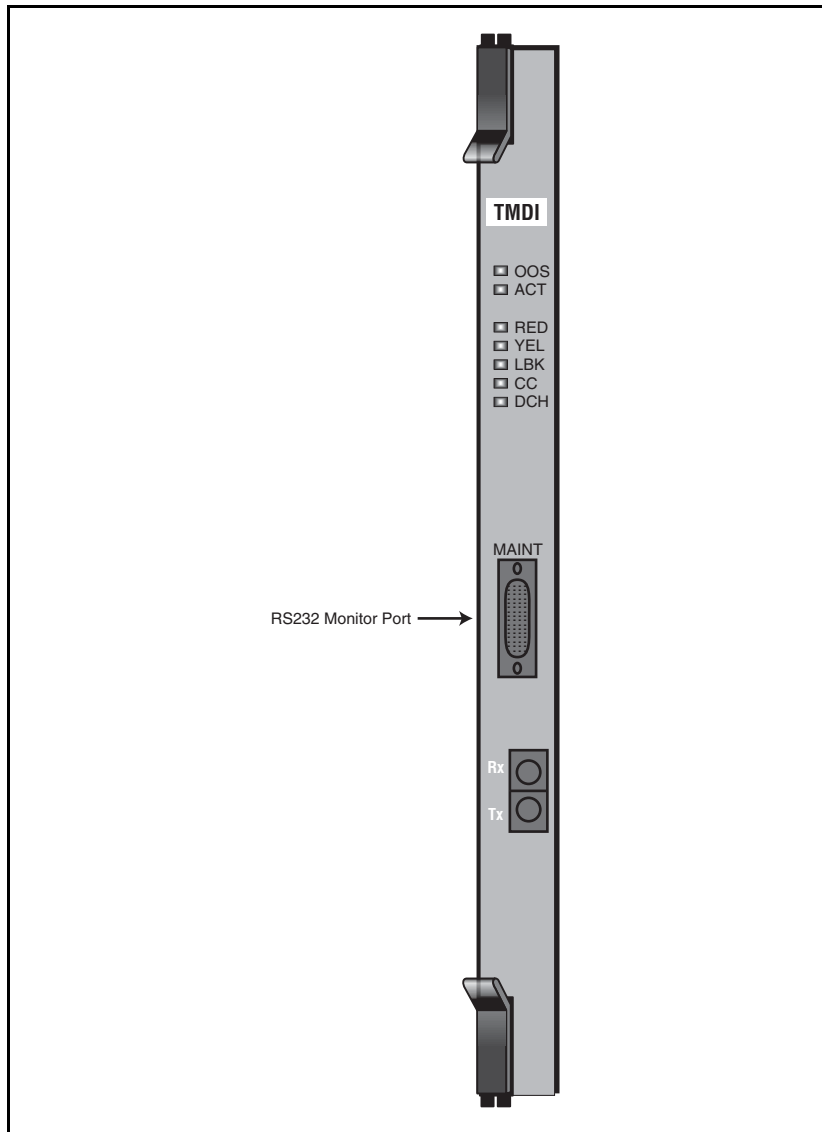
### Signaling interface

The signaling interface performs an 8 Kbps signaling for all 24 channels and interfaces directly to the DS-30X link. Messages transmitted in both directions are three bytes long.

### Interconnection

The interconnection to the carrier is by NTBK04, a 1.5 Mb 20 ft. carrier cable. The NT8D97AX, a fifty-foot extension cable, is also available.

**Figure 178**  
**NTRB21 TMDI card faceplate**





## Microprocessor

The NTRB21 is equipped with bit-slice microprocessors that handle the following major tasks:

- Task handler: also referred to as an executive. The task handler provides orderly per-channel task execution to maintain real-time task ordering constraints.
- Transmit voice: inserts digital pads, manipulates transmit AB bits for DS1, and provides graceful entry into T-Link data mode when the data module connected to the DTI/PRI trunk is answering the call.
- Receive voice: inserts digital pads and provides graceful entry into T-Link data mode when the data module connected to the DTI/PRI trunk is originating the call.
- T-Link data: a set of transmit and receive vectored subroutines which provides T-Link protocol conversion to and from the DM-DM protocol.
- Receive ABCD filtering: filters and debounces the receive ABCD bits and provides change of state information to the system.
- Diagnostics
- Self-test

## Digital pad

The digital pad is an EPROM whose address-input to data-output transfer function meets the characteristics of a digital attenuator. The digital pad accommodates both  $\mu$ 255-Law and A-Law coding. There are 32 combinations each for  $\mu$ 255 to  $\mu$ 255,  $\mu$ 255 to A-Law, A-Law to  $\mu$ 255, and A-Law to A-Law. These values are selected to meet the EIA loss and level plan.

**Table 263**  
**Digital pad values and offset allocations**

Offset	PAD set 0	PAD set 1
0	0dB	-7db
1	2dB	-8db
2	3dB	-9db
3	4dB	-10db
4	5dB	0.6db
5	6.1dB	7db
6	8dB	9db
7	-1dB	10db
8	-3dB	11db
9	-4dB	12db
A	idle code, 7F	3db
B	unassigned code, FF	14db
C	1dB	spare
D	-2dB	spare
E	-5db	spare
F	-6db	spare

### D-channel interface

The D-channel interface is a 64 kbps, full-duplex, serial bit-stream configured as a Data Circuit-terminating Equipment (DCE) device. The data signals include:

- receive data output
- transmit data input

- receive clock output
- transmit clock output

The bit rate of the receive and transmit clocks can vary slightly from each other. This is determined by the transmit and receive carrier clocks.

Feature selection through software configuration for the D-channel includes:

- 56 kbps
- 64 kbps clear
- 64 kbps inverted (64 Kbps restricted)

DCHI can be enabled and disabled independent of the PRI card, as long as the PRI card is inserted in its cabinet slot. The D-channel data link cannot be established unless the PRI loop is enabled.

On the NTRB21 use switch 1, position 1 to select either the D-channel feature or the DPNSS feature, as follows:

OFF = D-channel

The ON setting for DPNSS (U.K.) is not supported at this time.

## **DS-1 Carrier interface**

### **Transmitter**

The transmitter takes the binary data (dual unipolar) from the PCM transceiver and produces bipolar pulses for transmission to the external digital facility. The Digital Signal – Level 1 (DS-1) transmit equalizer enables the cabling distance to be extended from the card to the Digital Signal

Cross-connect – Level 1 (DSX-1), or LD-1. Equalizers are switch selectable through dip-switches. The settings are shown in Table 264.

**Table 264**  
**NTRB21 switch settings**

Distance to Digital Cross-Connect	Switch Setting			
	1 DCH F/W	2 (LEN 0)	3 (LEN 1)	4 (LEN 2)
0 - 133 feet	Off	Off	Off	On
133 - 266 feet	Off	On	On	Off
266 - 399 feet	Off	Off	On	Off
399 - 533 feet	Off	On	Off	Off
533 - 655 feet	Off	Off	Off	Off

**Receiver**

The receiver extracts data and clock from an incoming data stream and outputs clock and synchronized data. At worst case DSX-1 signal levels, the line receiver operates correctly with up to 655 feet of ABAM cable between the card and the external DS-1 signal source.

## Connector pinout

The connection to the external digital carrier is through a 15 position Male D-type connector.

**Table 265**  
**DS-1 line interface pinout for NTB04 cable**

From 50-pin MDF connector	To DB-15	Signal name	Description
pin 48	pin 1	T	transmit tip to network
pin 23	pin 9	R	transmit ring to network
pin 25	pin 2	FGND	frame ground
pin 49	pin 3	T1	receive tip from network
pin 24	pin 11	R1	receive ring from network

## NTAK20 Clock Controller (CC) daughterboard

Digital Trunking requires synchronized clocking so that a shift in one clock source results in an equivalent shift of the same size and direction in all parts of the network.

The NTA20 clock controller circuitry synchronizes the CS 1000S, CS 1000M Cabinet, and Meridian 1 PBX 11C Cabinet to an external reference clock and generates and distributes the clock to the system. The CS 1000S, CS 1000M Cabinet, and Meridian 1 PBX 11C Cabinet can function either as a slave to an external clock or as a clocking master to the network.

The NTA20AD and NTA20AA versions of the clock controller meet AT&T Stratum 3 and Bell Canada Node Category D specifications. The NTA20BD and NTA20BA versions meet CCITT stratum 4 specifications. See “NTA20 Clock Controller daughterboard” on [page 735](#).

**IMPORTANT!**

Each MG 1000S that has a digital trunk **must** have a clock controller clocked to an external reference clock.

If an IP Expansion multi-cabinet system is equipped with digital trunk cards, it is mandatory that at least one trunk card is placed in the Main Option 11C cabinet. A cabinet that has a digital trunk must have a clock controller.

*Note:* Clocking slips can occur between MG 1000S systems that are clocked from different COs, if the COs are not synchronized. The slips can degrade voice quality.

**Clock rate converter**

The 1.5 Mb clock is generated by a Phase-Locked Loop (PLL). The PLL synchronizes the 1.5 Mb DS1 clock to the 2.56 Mb system clock through the common multiple of 8 kHz by using the main frame synchronization signal.

---

# NTVQ01xx Media Card

---

## Contents

This section contains information on the following topics:

Physical description . . . . .	839
Hardware architecture . . . . .	841
Functional description . . . . .	843
Survivability . . . . .	843

## Physical description

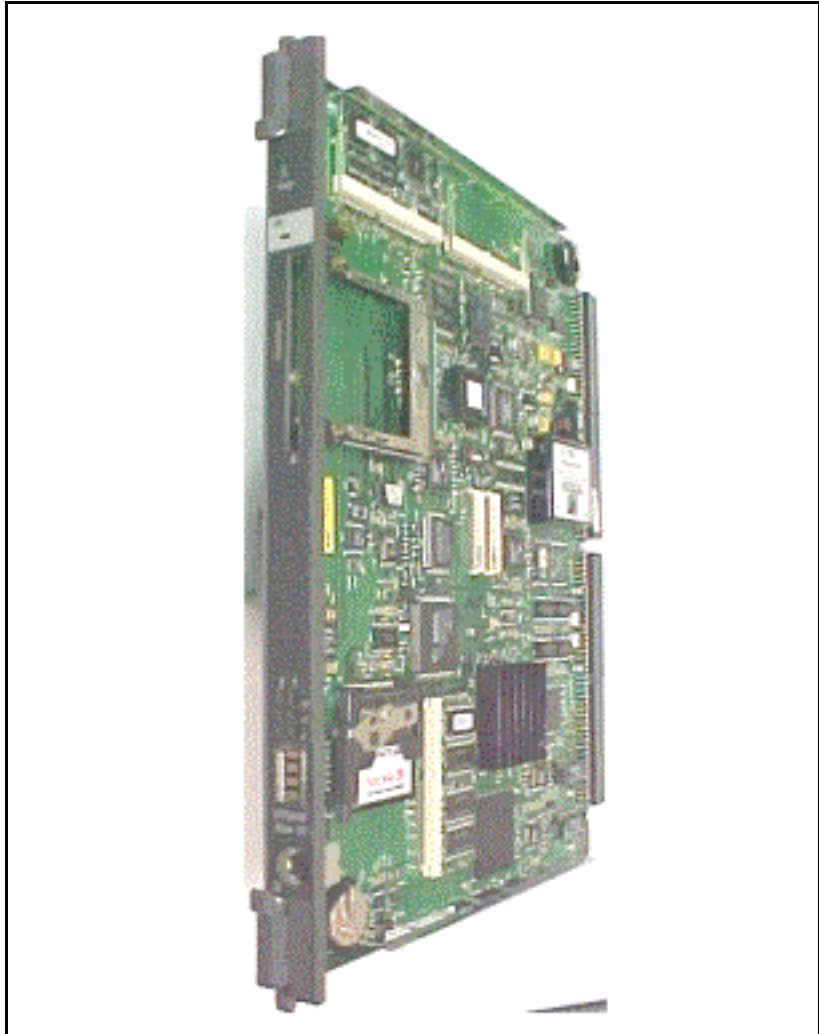
The Media Card replaces the ITG Pentium card and is available as an 8-port or 32-port card.

You can install this card in slots 1 through 4 in the MG 1000S or slots 7 through 10 in the MG 1000S Expansion.

**Note:** Up to four Media Cards can be installed in each MG 1000S. Up to four Media Cards can be installed in each MG 1000S Expansion.

An NTVQ01xx Media Card is shown in Figure 179.

**Figure 179**  
**NTVQ01xx Media Card**



The NTVQ01xx Media Card provides faceplate and backplane interfaces, which are used to connect external LANs. This section provides information on the faceplate connectors and indicators.



## Hardware architecture

The Media Card comes in two versions: 8-port and 32-port.

### Faceplate connectors and indicators

Figure 180 on [page 842](#) shows the NTVQ01xx Media Card faceplate.

#### Reset switch

The reset switch on the faceplate manually resets the Media Card.

#### Status LED

The NTVQ01xx Media Card faceplate red LED indicates the following:

- the enabled/disabled status of the card
- the self-testing result during power up or card insertion into an operational system

#### PC card slot

This slot accepts standard PC card flash cards, including ATA Flash cards (3 Mbit/s to 170 Mbit/s). Nortel supply PCM card adaptors which enable compact flash cards to be used in this slot. This slot is used for NTVQ01xx Media Card software upgrades, backing up announcements, and additional storage.

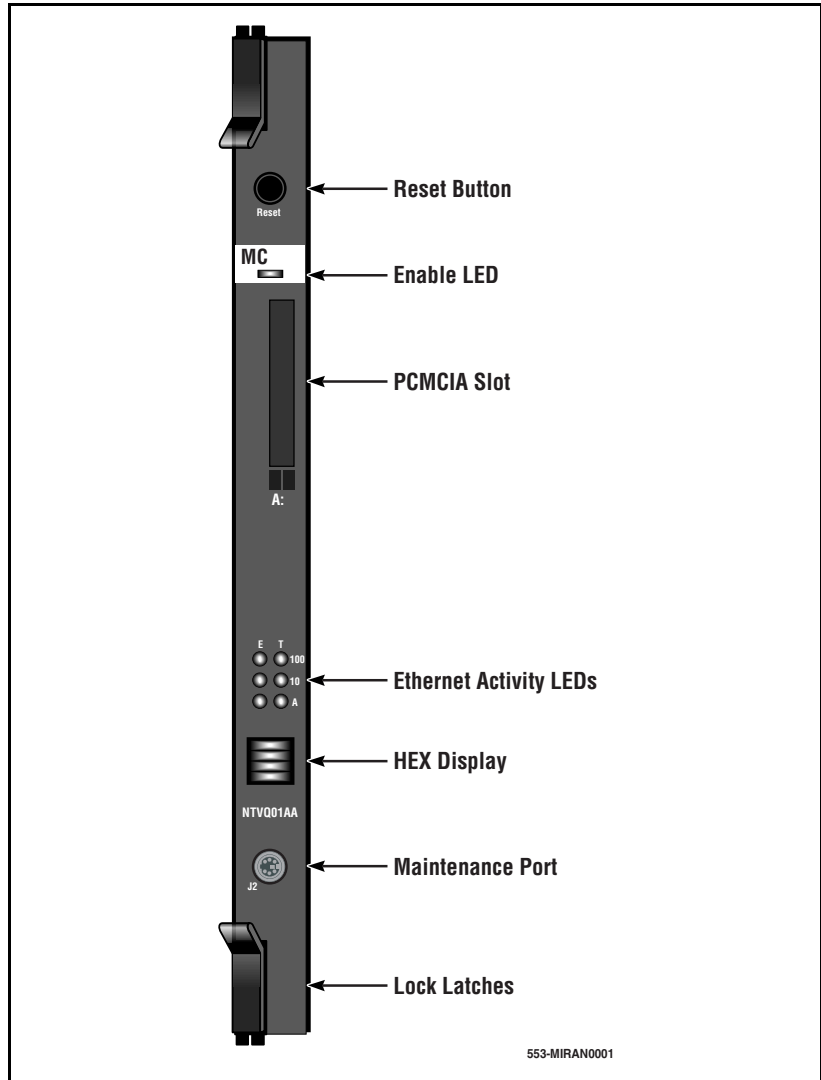
#### Ethernet activity LEDs

The NTVQ01xx Media Card faceplate contains Ethernet activity LEDs for each network.

#### Maintenance hex display

This is a four-digit LED-based hexadecimal display that provides the status of the NTVQ01xx Media Card at all times. The hex display provides an indication of fault conditions and the progress of PC card-based software upgrades or backups. It also indicates the progress of the internal self-test in the form of T:xx.

**Figure 180**  
**NTVQ01xx Media Card faceplate**



### **RS-232 Asynchronous Maintenance Port**

An 8-pin mini-DIN socket on the NTVQ01xx Media Card faceplate provides access to the RS-232 port. This faceplate port can provide access to the Media Card for OA&M purposes. The maintenance port is also available through a female DB9 connector on the 50-pin I/O Adaptor. This should be used to make a permanent terminal connection.

## **Functional description**

Media Cards have different types of firmware pre-installed, depending on the application being supported. The Voice Gateway application enables Digital Signal Processors (DSPs) for either line or trunk applications. When the Voice Gateway application is installed on the Media Card, the card is called the Voice Gateway Media card. Other examples of applications on a Media Card include IP Line 3.0 and Integrated Recorded Announcer.

The NTVQ01xx Media Card connects an IP and circuit-switched device. The DSPs perform media transcoding between IP voice packets and circuit-switched devices. The Media Card also provides echo cancellation and compression/decompression of voice streams.

## **Survivability**

Refer to *Communication Server 1000S: Installation and Configuration* (553-3031-210) for instructions on configuring the card for survivability.



---

# NTVQ55AA ITG Pentium card

---

## Contents

This section contains information on the following topics:

<a href="#">Physical description</a> . . . . .	845
<a href="#">Functional description</a> . . . . .	846

## Physical description

The NTVQ55AA ITG Pentium (ITG-P) card supports IP Phones by providing a communication gateway for the IP Phone between the IP data network and the system. The IP Phone uses the IP data network to communicate with the ITG-P card.

You can install this card in any two consecutive IPE slots.

**Note:** Each MG 1000S supports up to two ITG-P cards. Each MG 1000S Expansion supports up to two ITG-P cards. Each ITG-P card occupies two slots.

ITG-P cards have an ELAN management 10BaseT port and a TLAN VoIP port (10/100BaseT) on the I/O panel. There is an RS-232 Maintenance port connection on the ITG-P card faceplate and an alternative connection to the same serial port on the I/O backplane.

**Note:** Do not connect maintenance terminals to the faceplate and I/O panel serial maintenance port connections at the same time.

## Functional description

Figure 181 on [page 847](#) shows the ITG-P card faceplate components. The information in this section describes the components.

### Faceplate components

#### NWK

The faceplate connector labeled NWK is a 9-pin, sub-miniature D-type connector. The connector is not used for the ITG-P application.



#### WARNING

The NWK connector looks like a 9-pin serial connector. Do not connect a serial cable or any other cable to it. If a cable is installed to the NWK connector, the TLAN interface card is disabled.

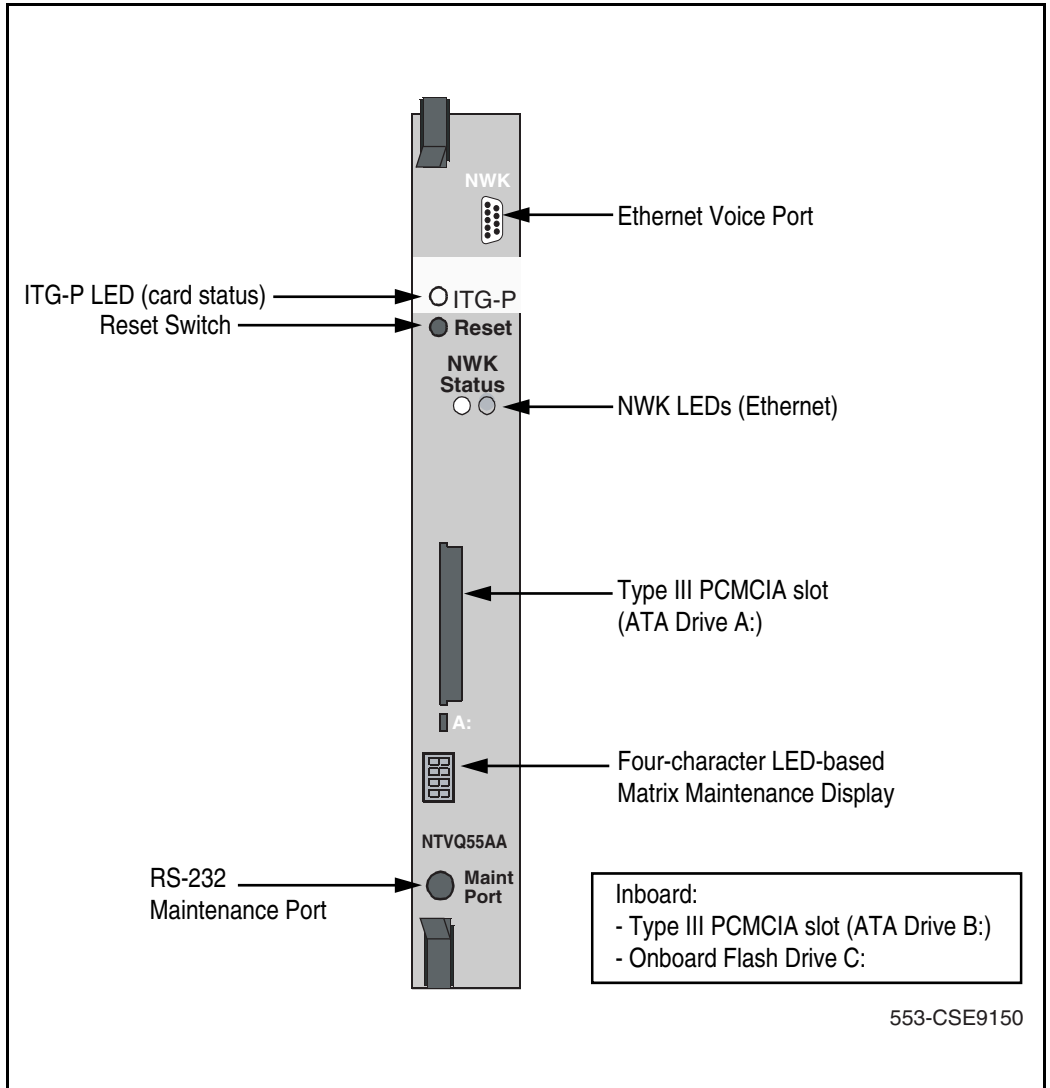
#### ITG-P LED (Card Status)

The red status faceplate LED indicates the enabled/disabled status of the 24-card ports. The LED is on (red) during the power-up or reset sequence. The LED remains lit until the card is enabled. If the LED remains on, this indicates the self-test failed, the card is disabled, or the card rebooted.

#### Reset switch

Press the Reset switch to reset the card without having to cycle power to the card. This switch is normally used after a software upgrade to the card, or to clear a fault condition.

**Figure 181**  
**NTVQ55AA ITG-P card faceplate**



**Note:** There are no Ethernet status LEDs for the ELAN management interface.

### **NWK Status LED**

NWK Status LEDs display the TLAN interface card Ethernet activity:

- Green – on if the carrier (link pulse) is received from the TLAN interface card Ethernet hub.
- Yellow – flashes when there is TLAN interface card data activity. During heavy traffic, yellow can stay continuously lit.

*Note:* There are no Ethernet status LEDs for the ELAN management interface.

### **PC card slots**

The ITG-P card has one faceplate PC card slot, designated drive A. The PC card slot is used for optional maintenance (backup and restore). The ITG-P card also has one unused inboard slot, designated drive B. The PC card slots support PC-based hard disks (ATA interface) or high-capacity PC flash memory cards.

### **Maintenance Display**

A four character, LED-based, dot matrix display shows the maintenance status fault codes and other card state information.

### **RS-232 Maintenance Port**

The ITG-P card faceplate provides a female DIN-8 serial maintenance port connection (labeled Maint Port). An alternative connection to the faceplate serial maintenance port exists on the NTMF94EA I/O panel breakout cable.

Do not connect maintenance terminals or modems to the faceplate and I/O panel DB-9 male serial maintenance port at the same time.

## **Backplane interfaces**

The backplane connector provides connection to the following:

- ELAN interface card
- TLAN interface card



- alternate connection to the serial maintenance port DS-30X
- Card LAN interfaces

**DS-30X voice/signaling**

DS-30X carries Pulse Code Modulation (PCM) voice and proprietary signaling on the backplane between the ITG-P card and the SSC.

**Card LAN**

Card LAN carries card polling and initialization messages on the backplane between the ITG-P card and the SSC.

**Assembly description**

The ITG-P card assembly consists of a two-slot motherboard/daughterboard combination. A PCI interconnect board connects the ITG-P motherboard and the DSP daughterboard.



---

# QPC513 Enhanced Serial Data Interface card

---

## Contents

This section contains information on the following topics:

<a href="#">Introduction</a> . . . . .	851
<a href="#">Physical description</a> . . . . .	852
<a href="#">Functional description</a> . . . . .	854
<a href="#">Connector pin assignments</a> . . . . .	859
<a href="#">Configuring the ESDI card</a> . . . . .	862
<a href="#">Applications</a> . . . . .	867

## Introduction

The QPC513 Enhanced Serial Data Interface (ESDI) card gives the CS 1000S, CS 1000M, and Meridian 1 switch two fully synchronous high-speed serial ports.

These high-speed synchronous ports are used to connect the processor to synchronous communication peripherals such as Meridian Mail or to a host computer (for example, DEC or Tandem) using Meridian Link. This card cannot be used as an asynchronous port or to connect to an administrative and maintenance terminal. Use either the NT8D41 SDI paddle board or the QPC841 Quad Serial Data Interface card to connect the switch to an asynchronous serial peripheral.

Each system can accommodate up to eight ESDI cards, for a total of 16 synchronous ports per system. The ESDI cards can be housed in the network slots of any of the following modules:

- NT5D21 Core/Network module (slots 0 through 7)
- NT6D39 CPU/Network module (slots 1 through 9 and 13)
- NT6D60 Core module (slots 0 through 5)
- NT8D35 Network module (slots 5 through 13)
- NT9D11 Core/Network module (slots 0 through 8)

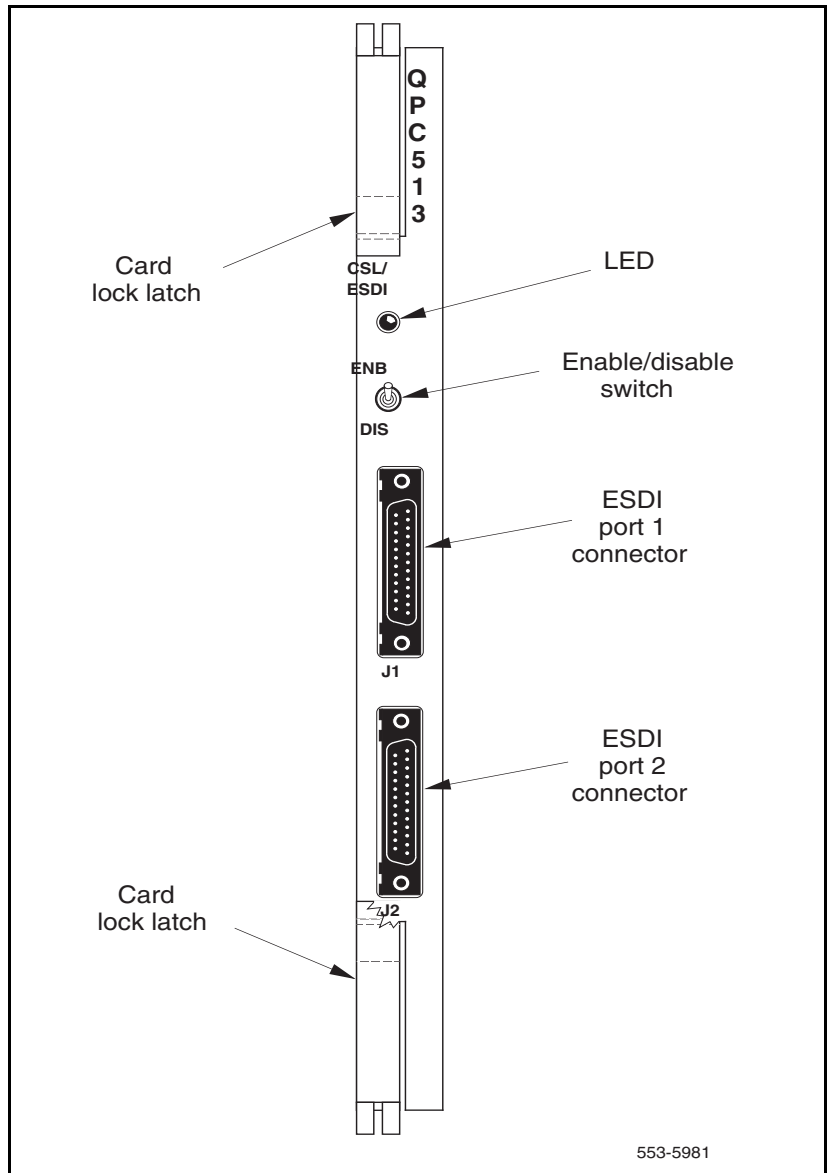
*Note:* When an ESDI card is installed in an NT6D60 Core module, an NT8D34 CPU module, or slot 13 of an NT6D39 CPU/Network module in a dual-CPU system, any I/O device connected to the card does not function when the CPU in that module is inactive.

## Physical description

The ESDI card circuitry is contained on a 31.75 by 25.40 cm (12.5 by 10 in.) printed circuit board. The front panel of the card is 2.54 cm (1 in.) wide. See Figure 182 on [page 853](#). The front panel is equipped with an Enable/Disable (ENB/DIS) switch and a red LED. The LED lights when the following occurs:

- the ENB/DIS switch is set to DIS
- both ports are disabled in software
- none of the card's ports have been configured in software
- the switch settings on the card do not match the settings programmed in software

Figure 182  
CPC513 ESDI card front panel



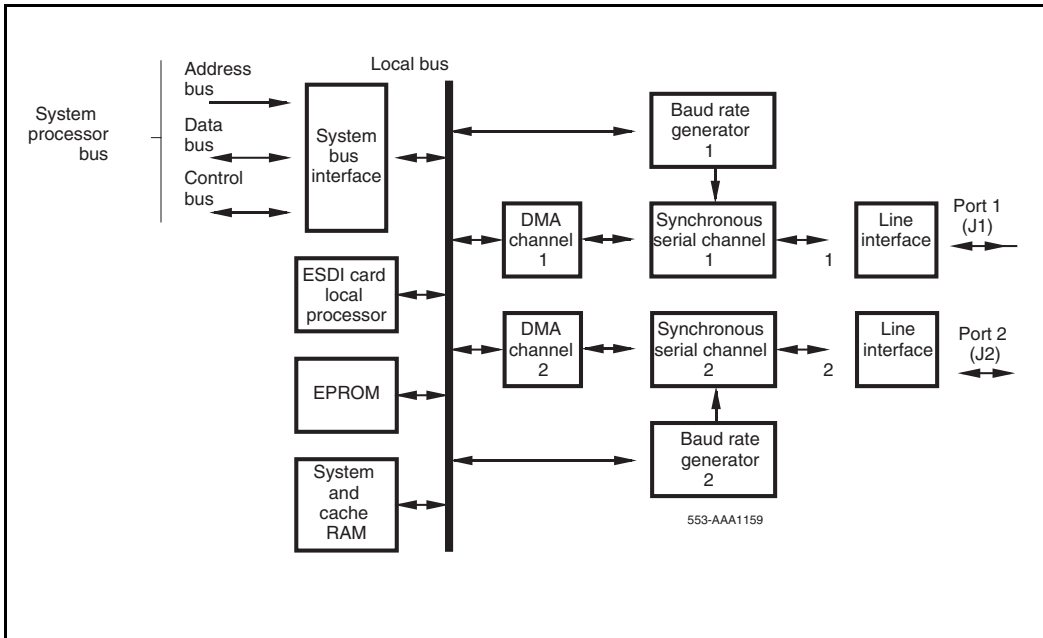
## Functional description

The QPC513 ESDI card is an intelligent, two-port synchronous serial data interface card. See Figure 183. The two serial input/output data ports terminate on DB-25 connectors on the front panel of the card.

Each port operates independently in synchronous mode, in half or full duplex, at speeds of up to 64 kbps. Each port can be connected to either Data Terminal Equipment (DTE) or Data Communications Equipment (DCE).

The electrical interface for the ESDI card may be either EIA RS-232-C or a proprietary high-speed interface. The high-speed interface combines features of RS-422-A for data and timing signals with features of RS-232-C for control signals.

**Figure 183**  
ESDI card block diagram



The QPC513 ESDI card is an intelligent controller. The local micro-processor performs all of the overhead associated with synchronous data transfer. The system processor passes data to the ESDI card processor a byte at a time using conventional memory reads and writes. The ESDI card processor stores the data in a RAM cache on the ESDI card, and passes it to the synchronous communication chip in blocks using Direct Memory Access (DMA) techniques.

## Synchronous communication

The ESDI cards supports LAPB, a subset of the HDLC synchronous protocol. A description of the LAPB protocol is shown in Appendix A, LAPB data link protocol on [page 901](#).

The HDLC data link is a bit-oriented protocol. The information data bits are transmitted transparently across the link in packets. The maximum length of the information field for these packets is 128 octets, where an octet consists of 8 bits.

The characteristics of the synchronous communication ports are shown in Table 266.

**Table 266**  
**Characteristics of synchronous ports (Part 1 of 2)**

Characteristics	Description
Duplex mode	half, (full)
Data rate (bps)	1200, 2400, (4800), 9600, 19200, 48000, 56000, 64000
Clock	(internal), external
Data Link Level LAPB protocol SL-1 address	(1), 3
<p><b>Note 1:</b> * See the Configuration Record (LD 17) in <i>Software Input/Output: Administration</i> (553-3001-311) to modify the link control system parameters and performance thresholds.</p> <p><b>Note 2:</b> The values in parentheses are the default.</p>	

**Table 266**  
**Characteristics of synchronous ports (Part 2 of 2)**

Characteristics	Description
Data Link Level LAPB protocol remote host address	(3), 1
Modify link control system parameters*	yes, (no)
Modify link performance thresholds (Note 1)	yes, (no)
<p><b>Note 1:</b> * See the Configuration Record (LD 17) in <i>Software Input/Output: Administration</i> (553-3001-311) to modify the link control system parameters and performance thresholds.</p> <p><b>Note 2:</b> The values in parentheses are the default.</p>	

## Clock timing option

The ESDI card offers two timing options:

- Internal: The ESDI card uses an internal timing source to synchronize data transfers to the external device.
- External: The ESDI card accepts a timing source from the high-speed interface connector to synchronize data transfers to the external device.

## Test and maintenance features

The ESDI card has these built-in testing and maintenance capabilities:

### Self-test

The ESDI card performs a self-test of its major components immediately after power-up. The self-test can also be initiated through the Link Diagnostic program LD 48. The self-test tests all ESDI functions up to, but not including, the ESDI line drivers and receivers.



### **Fault detection**

Firmware on the ESDI card detects hardware faults on the card and link level LAPB protocol faults. It reports the faults to the CPU when predetermined thresholds (downloaded at initialization) have been exceeded.

### **Fault isolation**

The ESDI/Command and Status Link (CSL) maintenance software takes the ESDI card out of service when the out-of-service thresholds are exceeded for the following:

- LAPB error conditions (for example, retransmission, Cyclic Redundancy Check (CRC) errors, overrun/underrun errors)
- Physical or link errors
- Detected hardware errors

## **Connection characteristics**

The two DB-25 connectors on the front panel of the ESDI card provide connections to each of the two I/O ports. The electrical interface of these connectors is a modified version of the RS-422-A standard designed to drive high-speed data over long cable lengths (up to 100 ft). Table 267 shows the interconnection specifications for these ports.

**Table 267**  
**QPC513 interconnection specifications**

<b>Distance</b>	<b>Interconnection</b>
<15.24 m (<50 ft)	Regular 25-conductor cable
>15.24 m and <30.48 m (>50 ft and <100 ft)	Twisted pair for balanced circuits
>30.48 m (>100 ft)	Network interface devices such as stand-alone modems or DS-1 facilities using Asynchronous/Synchronous Interface Module (ASIM) and Data Line card (DLC)

### Electrical interface options

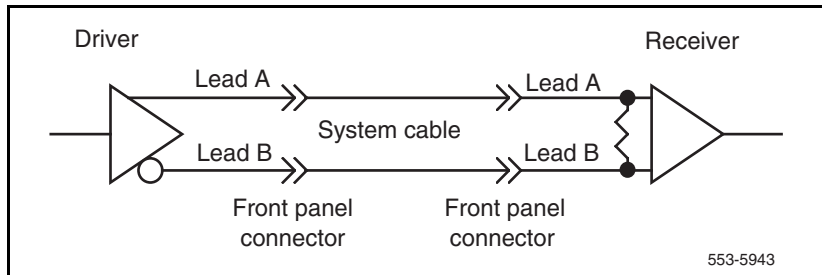
Interface options are selected by inserting jumper plugs into the appropriate sockets on the card:

- RS-232-C interface: The EIA RS-232-C interface can be used for speeds up to 19.2 kbps and distances of less than 15.24 m (50 ft). The ESDI card supports a subset of the RS-232-C signals. See Table 268 on [page 859](#).
- High-speed interface: The high-speed interface combines features of the RS-422-A standard for the data and timing signals with standard RS-232-C control signals. It is used when the signal rate is greater than 19.2 kbps and/or when the distance between the system and host is greater than 15.24 m (50 ft). No modems are needed if the distance is less than 30.48 m (100 ft).

The high-speed interface uses a proprietary pin assignment, rather than the standard 37-pin RS-449 arrangement. This pin arrangement is compatible with the Spectron Cable #75-025 for V.35 use. See Table 269 on [page 860](#).

The data and timing signals on the high-speed interface use RS-422-A type differential line drivers and receivers in a balanced configuration. These drivers and receivers are able to drive higher data rate signals over longer distances than standard RS-232-C drivers and receivers. A typical connection using these drivers and receivers is shown in Figure 184.

**Figure 184**  
**Typical high-speed interface line driver and receiver**



## Connector pin assignments

Table 268 shows the pin assignments for J1 and J2 when the port is configured for RS-232-C interface, and Table 269 on [page 860](#) shows the pin assignments for J1 and J2 when the port is configured for the high-speed interface.

**Table 268**  
**Connector J1 and J2 pin assignments – RS-232-C interface (Part 1 of 2)**

Pin number	Signal functions	Signal source		EIA circuit
		To DCE	From DCE	
<b>Ground and common return</b>				
1	Shielded	n/a	n/a	
7	Signal ground (SG)	n/a	n/a	AB
<b>Data</b>				
2	Transmitted data (TX)	3	—	BA
3	Received data (RX)	—	3	BB
<b>Control</b>				
4	Request to send (RTS)	3	—	CA
5	Clear to send (CTS)	—	3	CB
6	Data set ready (DSR)	—	3	CC
8	Carrier detect (CD)	—	3	CF
20	Data terminal ready (DTR)	3	—	CD
<b>Timing</b>				
15	Transmitter signal element timing (DCE)	—	3	DB

**Note:** Pins not used are 9 to 14, 16, 18, 19, 21, 22, 25.

**Table 268**  
**Connector J1 and J2 pin assignments – RS-232-C interface (Part 2 of 2)**

Pin number	Signal functions	Signal source		EIA circuit
		To DCE	From DCE	
17	Receiver signal element timing (DCE)	—	3	DD
24	Transmitter signal element timing (DTE)	3	—	DA

**Note:** Pins not used are 9 to 14, 16, 18, 19, 21, 22, 25.

**Table 269**  
**Connector J1 and J2 pin assignments – high-speed interface (Part 1 of 2)**

Pin number	Signal functions	Signal source		EIA circuit (lead)
		To DCE	From DCE	
<b>Ground and common return</b>				
1	Shield	n/a	n/a	
7	Signal ground (SG)	n/a	n/a	AB
<b>Data</b>				
2	Transmitted data – lead A	3	—	BA (A)
3	Received data – lead A	—	3	BB (A)
13	Transmitted data – lead B	3	—	BA (B)
16	Received data – lead B	—	3	BB (B)
<b>Control</b>				
4	Request to send (RTS)	3	—	CA
5	Clear to send (CTS)	—	3	CB
6	Data set ready (DSR)	—	3	CC
8	Carrier detect (CD)	—	3	CF
20	Data terminal ready (DTR)	3		CD

**Note:** Pins not used are 9, 10, 11, 18, 19, 21, 22, 25.

**Table 269**  
**Connector J1 and J2 pin assignments – high-speed interface (Part 2 of 2)**

Pin number	Signal functions	Signal source		EIA circuit (lead)
		To DCE	From DCE	
<b>Timing</b> 12	Transmitter signal element timing (DTE) – lead B	—	3	DD (B)
14	Transmitter signal element timing (DCE) – lead B	—	3	DB (B)
15	Transmitter signal element timing (DCE) – lead A	—	3	DB (A)
17	Transmitter signal element timing (DTE) – lead A	—	3	DD (A)
23	Receiver signal element timing (DCE) – lead A	3	—	DA (A)
24	Receiver signal element timing (DCE) – lead B	3	—	DA (B)
<b>Note:</b> Pins not used are 9, 10, 11, 18, 19, 21, 22, 25.				

## Configuring the ESDI card

Configuring the ESDI card consists of setting the port addresses using the address selection switch and setting the port interface options using the jumper blocks. The system software must then be configured to recognize the ESDI card. Figure 185 on [page 864](#) shows the location of all option switches and jumper sockets on the ESDI card.

### Address switch settings

The two ESDI ports on the card are addressed in pairs such as 0 and 1, 2 and 3, and so on). The address is set using switch S2. The switch settings used to select the address vary depending on whether the card is Style A or Style B. The “Style” can be read on the printed circuit board silk screen. The address of the card is set to match the device address defined in software.

Synchronous port address space is the same as asynchronous port address space. When selecting an address for the ESDI card, make sure that it will not conflict with an address currently being used by an asynchronous card.

Table 270 shows the ESDI card address switch settings.

**Table 270**  
**ESDI card address switch settings (Part 1 of 2)**

Device Number		Switch S2 style A				Switch S2 style B			
Port 1	Port 2	1	2	3	4	1	2	3	4
0	1	off	off	off	on	off	off	off	*
2	3	on	off	off	on	off	off	on	*
4	5	off	on	off	on	off	on	off	*
6	7	on	on	off	on	off	on	on	*
8	9	off	off	on	on	on	off	off	*
10	11	on	off	on	on	on	off	on	*

\* Switch S2, position 4 is not used on style B cards.

**Table 270**  
**ESDI card address switch settings (Part 2 of 2)**

Device Number		Switch S2 style A				Switch S2 style B			
Port 1	Port 2	1	2	3	4	1	2	3	4
12	13	off	on	on	on	on	on	off	*
14	15	on	on	on	on	on	on	on	*

\* Switch S2, position 4 is not used on style B cards.

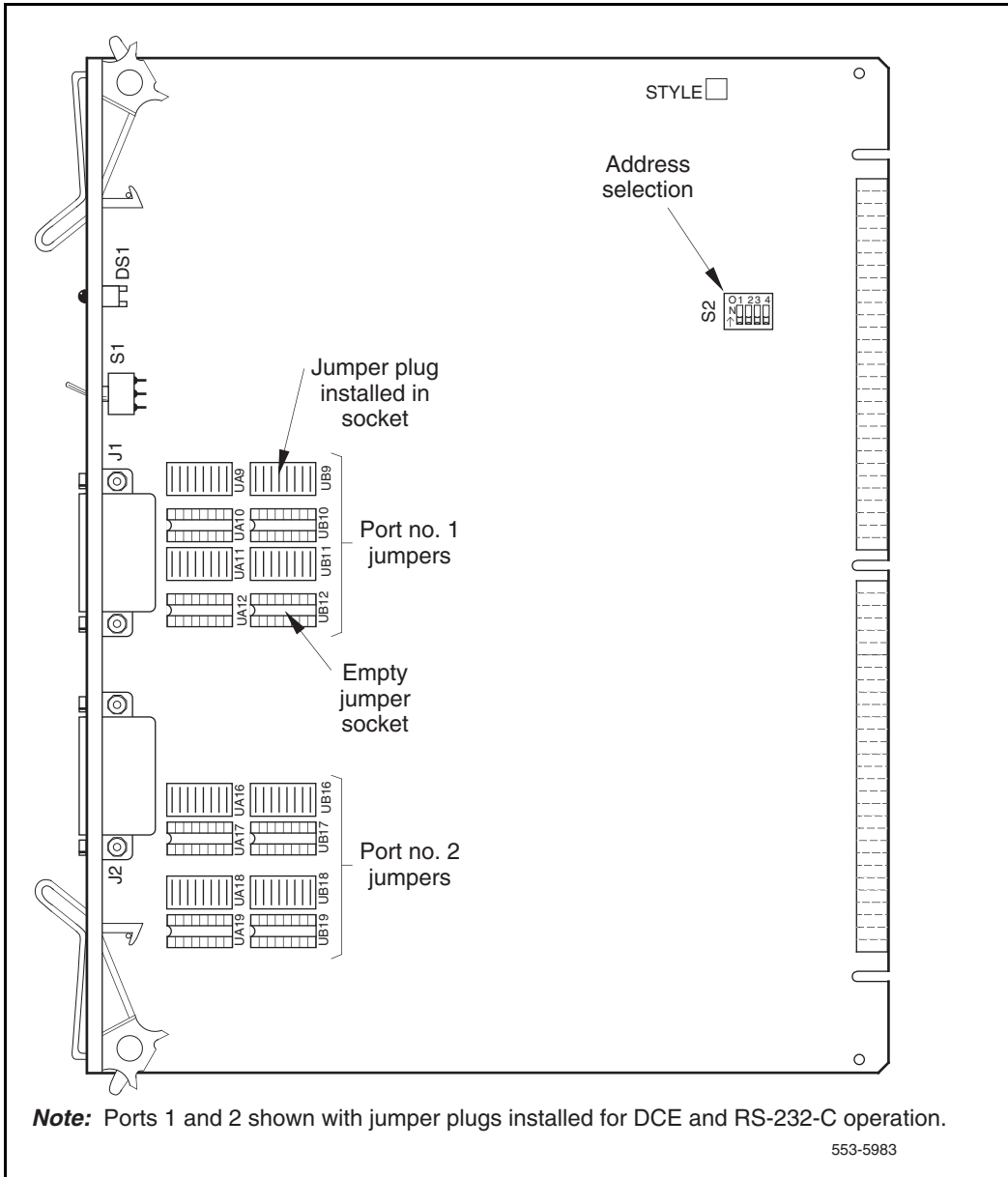
## DTE/DCE mode jumper settings

The interface for each ESDI port is configured independently. Ports must be configured both for electrical interface (RS-232-C or high-speed) and mode (DTE or DCE). With the proper options set:

- An ESDI port configured as DTE appears as a terminal to the user equipment.
- An ESDI port configured as DCE appears as a modem to the user equipment.

Interface options are set by installing option jumper plugs into the sockets indicated in Table 271 on [page 865](#) and Table 272 on [page 865](#).

**Figure 185**  
**ESDI card option switch locations**





**Table 271**  
**ESDI card DTE/DCE mode jumper settings**

Mode	Port	Jumper socket designations	
		Data communication equipment (DTE)	1
Data terminal equipment (DCE)	1	UA9	UA11
Data communication equipment (DTE)	2	UA17	UA19
Data terminal equipment (DCE)	2	UA16	UA18

**Table 272**  
**ESDI card RS-232-C/high-speed interface jumper settings**

Mode	Port	Jumper socket designations	
		RS-232-C interface	1
High-speed interface	1	UB10	UB12
RS-232-C interface	2	UB16	UB18
High-speed interface	2	UB17	UB19

## Software service changes

All of the other ESDI port operating parameters are defined in software and downloaded to the assigned ESDI port. See Table 266 on [page 855](#). These changes are made using the Configuration Record program (LD 17). Instructions for the Configuration Record program are found in the *Software Input/Output: Administration* (553-3001-311).

Some of the prompts that are commonly used when running the Configuration Record program (LD 17) are shown in LD 17 – Serial port configuration

parameters. These parameters must be set for each ports if both ports are being used.

**LD 17 – Serial port configuration parameters.**

Prompt	Response	Description
REQ:	CHG	Change configuration.
TYPE:	CFN	Configuration type.
IOTB	YES	Change input/output devices.
ADAN	NEW TTY x NEW PRT x	Define a new system terminal (printer) port as device x, where x = 0 to 15.
CDNO	1-16	Use the ESDI card number to keep track of all ports.
DENS	DDEN	Double density SDI paddle board.
USER	xxx	Enter the user of port x. The values that can be entered depend on the software being used. See the <i>Software Input/Output: Administration</i> (553-3001-311) for details.
XSM	(NO) YES	Port is used for the system monitor.

## Applications

The QPC513 Enhanced Serial Data Interface card is used any time that a high-speed, fully synchronous serial data communication channel is needed. The ESDI card is typically used to connect to the following:

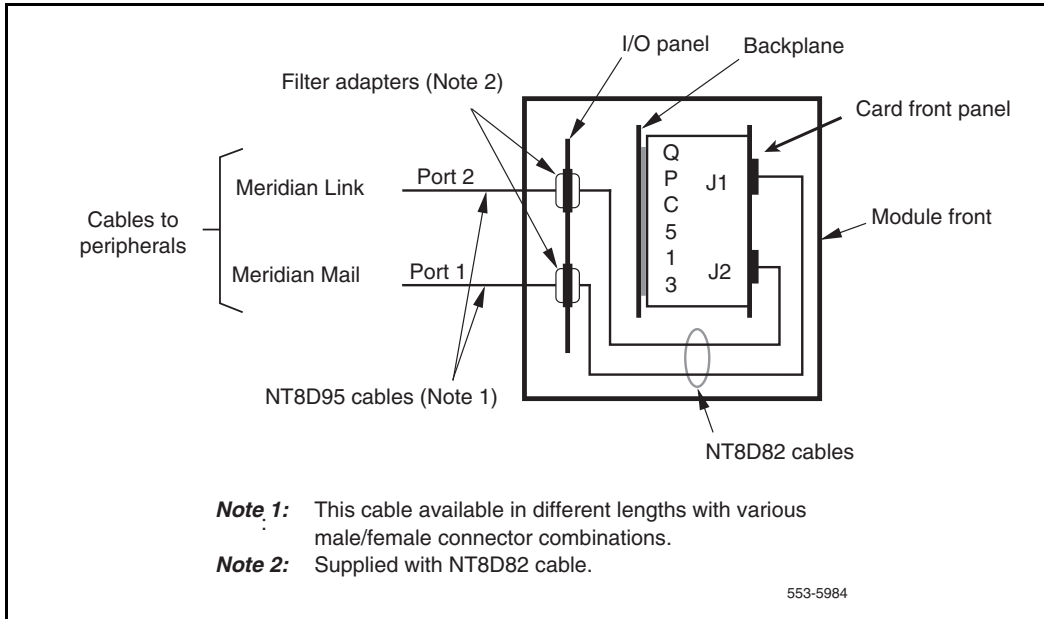
- Meridian Mail
- A host computer using Meridian Link
- An auxiliary processor

The system processor transfers data to the ESDI card in blocks consisting of 1 to 128 eight-bit octets. Each block is processed in accordance with the LAPB subset of the HDLC protocol and is transmitted serially to the output port.

In receive mode, the ESDI card receives data serially from the input port packages in LAPB information frames. After determining that the block is error-free, the ESDI card supplies the data to the system processor as a block.

The ESDI card serial ports terminate on the card front panel. [Figure 186 on page 868](#) shows the typical ESDI card connections in a system.

**Figure 186**  
**QPC513 ESDI card cabling**



---

# QPC841 Quad Serial Data Interface card

---

## Contents

This section contains information on the following topics:

Introduction . . . . .	869
Physical description . . . . .	870
Functional description . . . . .	872
Connector pin assignments . . . . .	874
Configuring the QSDI card . . . . .	876
Applications . . . . .	882

## Introduction

The QPC841 Quad Serial Data Interface (QSDI) card provides four RS-232-C serial ports between the system and external devices. The QSDI card plugs into a slot in the common equipment area of any system.

The Quad Serial Data Interface card is normally used to connect the system to its administration and maintenance terminal. It is also used to connect the system to a background terminal (used in the Hotel/Motel environment), a modem, or the Automatic Call Distribution (ACD) and Call Detail Recording (CDR) features.

The QSDI card is compatible with all existing system software. It does not support 20 mA current loop interface.

QSDI cards are housed in the following modules:

- NT5D21 Core/Network module (slots 0 through 7)
- NT6D39 CPU/Network module (slots 1 through 9, and 13)
- NT6D60 Core module (slots 0 through 5)
- NT8D35 Network module (slots 5 through 13)
- NT9D11 Core/Network module (slots 0 through 8)

*Note:* When a QSDI card is installed in an NT6D60 Core module, an NT8D34 CPU module, or slot 13 of an NT6D39 CPU/Network module in a dual-CPU system, any input/output I/O device connected to the card does not function when the CPU in that module is inactive.

## Physical description

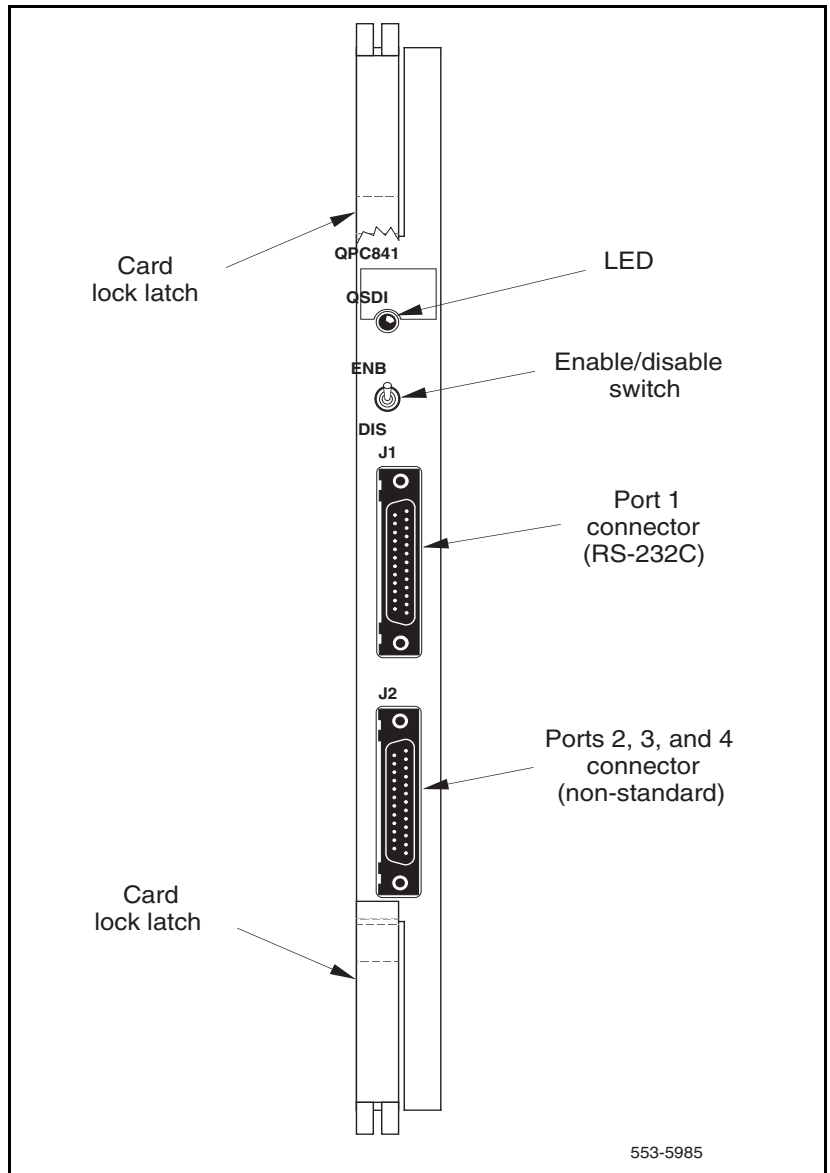
The QPC841 QSDI card is a printed circuit board measuring 31.75 cm by 25.4 cm (12.5 in. by 10 in.). The front panel is 2.54 cm (1 in.) thick. See Figure 187 on [page 871](#).

Up to four QSDI boards can be used in a system, allowing a total of sixteen asynchronous serial ports. The four serial ports on each card are addressed as two pairs of consecutive addresses (0 and 1, 2 and 3, and so on up to 14 and 15). The pairs need not be consecutive. For example: pairs 0 and 1, and 4 and 5 could be used.

The card front panel has two connectors, J1 and J2. Connector J1 is used for port 1 while connector J2 is used for ports 2, 3, and 4. It also has an Enable/Disable (ENB/DIS) switch and a red LED. The LED indicates that the card has been disabled. It is lit when the following occurs:

- the ENB/DIS switch is set to DIS
- all of the ports on the card are disabled in software
- none of the card ports are configured in software

Figure 187  
QPC841 QSDI card front panel



## Functional description

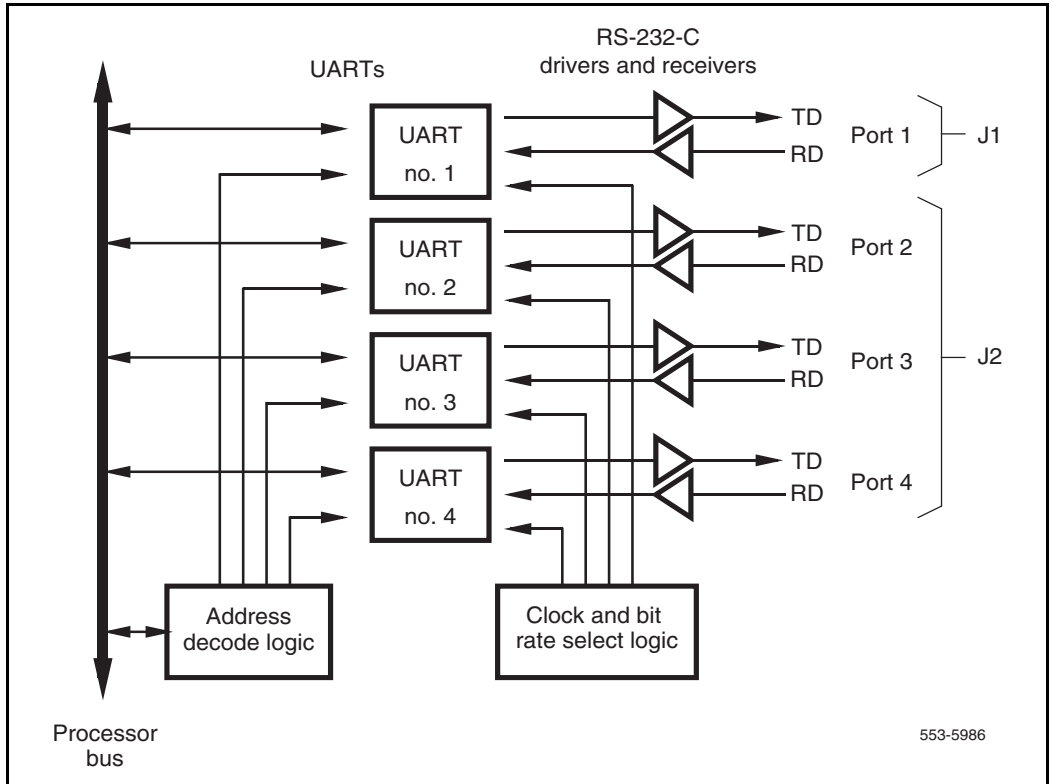
The QPC841 Quad Serial Data Interface card contains all the logic for four asynchronous serial ports, including the baud rate generators. These serial ports are directly accessed by the system processor using memory reads and writes.

The QPC841 Quad Serial Data Interface card contains four universal asynchronous receiver/transmitters (UARTs) and the logic necessary to connect the UARTs to the system processor bus. See Figure 188 on [page 873](#). The other logic on the card consists of four baud rate generators, four RS-232-C driver/receiver pairs, and the jumpers and logic needed to configure the UARTs.

The address select switches and logic on the card always address the UARTs using two pairs of addresses: 0 and 1, and 2 and 3 through 15 and 16. The pairs do not need to be consecutive. Other switches on the board determine the baud rate for each individual port and whether the port is configured to talk to a terminal (DTE equipment) or a modem (DCE equipment). Instructions for setting the jumpers are given later in this section.



Figure 188  
QPC841 QSDI card block diagram



## Connector pin assignments

Connector J1 is connected to port one, and uses the RS-232-C standard DB-25 pinout. Connector J2 is connected to ports two, three, and four, and is a non-standard pinout that requires an adapter cable. An adapter cable (NT8D96) splits the J2 signals out to three standard RS-232-C connectors. Port 2 is connected to connector A, Port 3 is connected to connector B, and Port 4 is connected to connector C.

Table 273 shows the pinouts for connector J1, and Table 274 on [page 875](#) shows the pinouts for connector J2.

**Table 273**  
**Connector J1 pin assignments**

Pin number	Signal	Purpose in DTE mode	Purpose in DCE mode
1	FGD	Frame ground	Frame ground
2	TD	Received data	Transmitted data
3	RD	Transmitted data	Received data
4	RTS	Request to send (not used)	Request to send (Note 2)
5	CTS	Clear to send (Note 1)	Clear to send
6	DSR	Data set ready (Note 1)	Data set ready
7	GND	Ground	Ground
8	CD	Carrier detect (Note 1)	Carrier detect (not used)
20	DTR	Data terminal ready	Data terminal ready (Note 2)

**Note 1:** In DTE mode, the signals CD, DSR, and CTS are tied to +12 volts (through a resistor) to indicate that the QSDI port is always ready to transmit and receive data.

**Note 2:** In DCE mode, the signals DTR, and RTS are tied to +12 volts (through a resistor) to indicate that the QSDI port is always ready to transmit and receive data.

**Table 274**  
**Connector J2 pin assignments (Part 1 of 2)**

Pin Number	Port	Signal	Purpose in DTE mode	Purpose in DCE mode
1		FGD	Frame ground	Frame ground
2		TD	Transmitted data	Transmitted data
3		RD	Received data	Received data
4		RTS	Request to send (not used)	Request to send (Note 2)
5	2	CTS	Clear to send (Note 1)	Clear to send
6		DSR	Data set ready (Note 1)	Data set ready
7		GND	Ground	Ground
8		CD	Carrier detect (Note 1)	Carrier detect (not Used)
20		DTR	Data terminal ready	Data terminal ready (Note 2))
9		TD	Transmitted data	Transmitted data
10		RD	Received data	Received data
11		RTS	Request to send (not used)	Request to send (Note 2))
12	3	CTS	Clear to send (Note 1)	Clear to send
13		DSR	Data set ready (Note 1)	Data set ready
25		GND	Ground	Ground
24		CD	Carrier detect (Note 1)	Carrier detect (not used)
23		DTR	Data terminal ready	Data terminal ready (Note 2))
14		TD	Transmitted data	Transmitted data
15		RD	Received data	Received data
16		RTS	Request to send (not used)	Request to send (Note 2))
17	4	CTS	Clear to send (Note 1)	Clear to send
18		DSR	Data set ready (Note 1)	Data set ready

**Table 274**  
**Connector J2 pin assignments (Part 2 of 2)**

Pin Number	Port	Signal	Purpose in DTE mode	Purpose in DCE mode
19		GND	Ground	Ground
21		CD	Carrier detect (Note 1)	Carrier detect (not used)
22		DTR	Data terminal ready	Data terminal ready (Note 2))

**Note 1:** In DTE mode, the signals CD, DSR, and CTS are tied to +12 volts (through a resistor) to indicate that the QSDI port is always ready to transmit and receive data.

**Note 2:** In DCE mode, the signals DTR and RTS are tied to +12 volts (through a resistor) to indicate that the QSDI port is always ready to transmit and receive data.

## Configuring the QSDI card

Configuring the QSDI card consists of setting these option switches for each serial port:

- Port address
- Baud rate
- DTE/DCE mode

Figure 189 on [page 880](#) shows the location of the option switches on the QSDI card. Instructions for setting these switches are in the section that follows.

### Address switch settings

Table 275 on [page 877](#) lists the address switch settings for the QPC841 Quad Serial Data Interface card. The address select jumpers and logic on the card address the UARTs using two pairs of addresses: 0 and 1, 2 and 3, through 15 and 16. The pairs do not need to be consecutive. Switch SW14 is used to

select the addresses for ports 1 and 2. Switch SW15 is used to select the addresses for ports 3 and 4.

**Table 275**  
**QSDI card address switch settings**

SW14	Port 1	Port 2	Switch settings							
SW15	Port 3	Port 4	1	2	3	4	5	6	7	8
<b>Device pair addresses</b>	0	1	off	off	off	off	off	on	on	on
	2	3	off	off	off	off	off	on	on	off
	4	5	off	off	off	off	off	on	off	on
	6	7	off	off	off	off	off	on	off	off
	8	9	off	off	off	off	off	off	on	on
	10	11	off	off	off	off	off	off	on	off
	12	13	off	off	off	off	off	off	off	on
	14	15	off	off	off	off	off	off	off	off

**Note 1:** On SW16, positions 1, 2, 3, and 4 must be OFF.

**Note 2:** To avoid address conflicts, SW14 and SW15 can never have identical settings.

**Note 3:** To disable ports 1 and 2, set SW14 position 1 to ON. To disable ports 3 and 4, set SW15 position 1 to ON.

### Baud rate switch settings

Table 276 lists the switch settings necessary to set the baud rate.

**Table 276**  
**QSDI card baud rate switch settings**

Baud rate	Port 1 – SW10				Port 2 – SW11				Port 3 – SW12				Port 4 – SW13			
	1	2	3	4	1	2	3	4	1	2	3	4	1	2	3	4
150	off	off	on	on	off	off	on	on	off	off	on	on	off	off	on	on
300	off	on	off	on	off	on	off	on	off	on	off	on	off	on	off	on
600	off	off	off	on	off	off	off	on	off	off	off	on	off	off	off	on
1200	off	on	on	off	off	on	on	off	off	on	on	off	off	on	on	off
2400	off	off	on	off	off	off	on	off	off	off	on	off	off	off	on	off
4800	off	on	off	off	off	on	off	off	off	on	off	off	off	on	off	off
9600	off	off	off	off	off	off	off	off	off	off	off	off	off	off	off	off

**DTE/DCE mode switch settings**

Table 277 shows the DTE/DCE mode selection switches for the four serial ports.

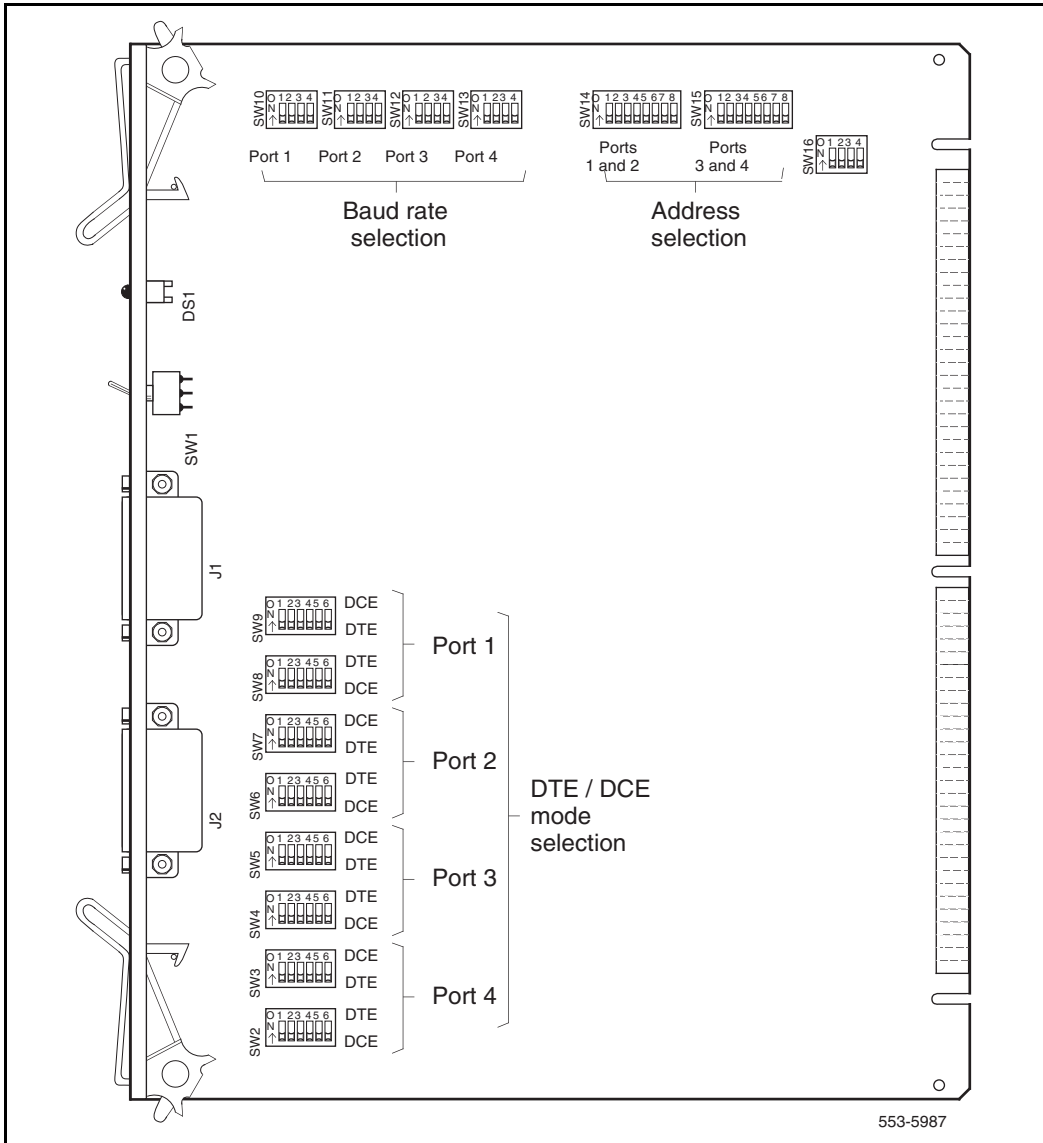
**Table 277**  
**QSDI card DTE/DCE mode switch settings**

	Port 1 – SW8						Port1 – SW9					
Mode	1	2	3	4	5	6	1	2	3	4	5	6
DTE (Terminal)	on	on	on	on	on	on	off	off	off	off	off	off
DCE (Modem)	off	off	off	off	off	off	on	on	on	on	on	on
	Port 2 – SW6						Port 2 – SW7					
Mode	1	2	3	4	5	6	1	2	3	4	5	6
DTE (Terminal)	on	on	on	on	on	on	off	off	off	off	off	off
DCE (Modem)	off	off	off	off	off	off	on	on	on	on	on	on
	Port 3 – SW4						Port 3 – SW5					
Mode	1	2	3	4	5	6	1	2	3	4	5	6
DTE (Terminal)	on	on	on	on	on	on	off	off	off	off	off	off
DCE (Modem)	off	off	off	off	off	off	on	on	on	on	on	on
	Port 4 – SW2						Port 4 – SW3					
Mode	1	2	3	4	5	6	1	2	3	4	5	6
DTE (Terminal)	on	on	on	on	on	on	off	off	off	off	off	off
DCE (Modem)	off	off	off	off	off	off	on	on	on	on	on	on

**Test switch setting**

Switch SW16 is only used for factory testing; all of its switches must be set to OFF for proper operation.

**Figure 189**  
**QSDI card option switch locations**





## Software service changes

Once the QPC841 QSDI card has been installed in the system, the system software needs to be configured to recognize it. This is done using the Configuration Record program LD 17. Instructions for running the Configuration Record program are found in *Software Input/Output: Administration* (553-3001-311).

Some of the prompts that are commonly used when running the Configuration Record program LD 17 are shown in LD 17 – Serial port configuration parameters. These parameters must be set for each port that is being used.

### LD 17 – Serial port configuration parameters.

Prompt	Response	Description
REQ:	CHG	Change configuration.
TYPE:	CFN	Configuration type.
IOTB	YES	Change input/output devices.
ADAN	NEW TTY x NEW PRT x	Define a new system terminal (printer) port as device x, where x = 0 to 15.
CDNO	1-16	Use the QSDI card number to keep track of all ports.
DENS	DDEN	Double density SDI paddle board.
USER	xxx	Enter the user of port x. The values that can be entered depend on the software being used. See <i>Software Input/Output: Administration</i> (553-3001-311) for details.
XSM	NO YES	Port is used for the system monitor.

## Applications

The QPD841 Quad Serial Data Interface (QSDI) card is used to connect the switch to a variety of communication devices and peripherals. Any RS-232-C compatible device can be connected to any of the four serial ports.

The standard application for the QSDI card is to connect the switch to the system console. This can be either a direct connection if the console is located near the switch, or through a modem for remote maintenance.

Bell 103/212 compatible dumb modems are recommended to connect a remote data terminal. If a smart modem (such as a Hayes modem) is used, select the dumb mode of operation (Command Recognition OFF, Command Echo OFF) before connecting the modem to the asynchronous port.

Serial data interface connector J1 is a standard RS-232-C DB-25 connector that connects port 1 of the QSDI card to outside peripherals. Connector J2 is non-standard in that it contains the connections for the three remaining serial ports (ports 2, 3, and 4), on a single DB-25 connector. An adapter cable must be used to connect to standard RS-232-C peripherals. Cables that are applicable to the QSDI card are:

- SDI male-to-female flat cables (internal module use only)
  - NT8D82
  - QCAD290

*Note:* This cable is available in different lengths. Refer to the *Equipment Identification* (553-3001-154) for more information

— QCAD42

- SDI male-to-male round cables (external use only)
  - NT8D95
- SDI to I/O cables (system options use only)
  - NT8D82

*Note:* This cable is available in different lengths. Refer to *Equipment Identification* (553-3001-154) for more information

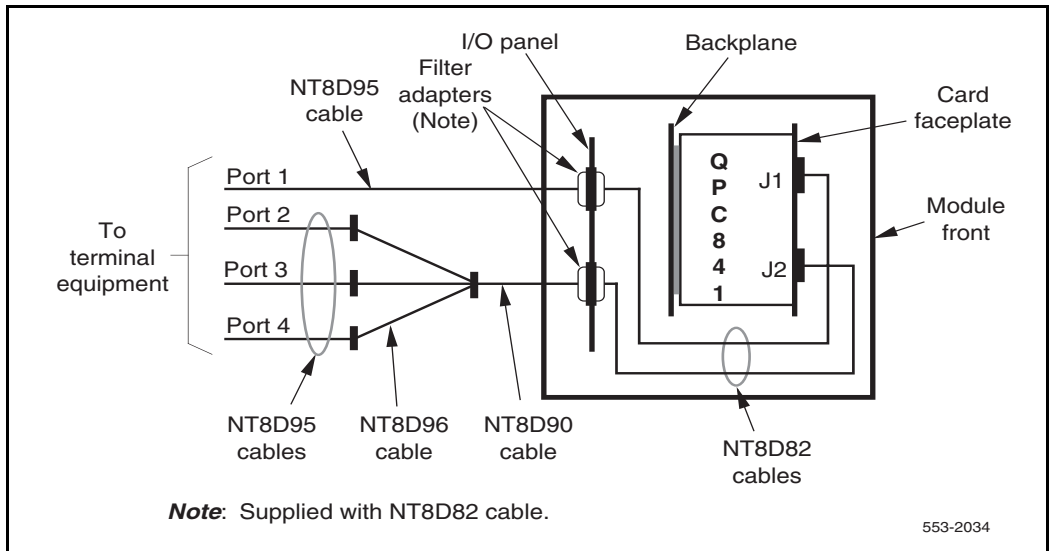
- SDI multiple-port cable (internal system options use only)
  - NT8D90
- SDI I/O to DTE/DCE cables (system options use only)
  - NT8D95

**Note:** This cable is available in different lengths. Refer to *Equipment Identification* (553-3001-154) for more information

- SID Multiple-port cable (system options use only)
  - NT8D96

Figure 190 shows the QPC841 card and the cables listed above in a standard configuration.

**Figure 190**  
**QPC841 QSDI card cabling**





---

# The TDS/DTR card

---

## Contents

This section contains information on the following topics:

<a href="#">Introduction</a> . . . . .	885
<a href="#">Features</a> . . . . .	886

## Introduction

The TDS/DTR card function was incorporated into the NTDK20 SSC. However, it is still supported on the system.

The TDS/DTR functionality is also incorporated into the NTDK97 MSC card used with Chassis system. The TDS/DTR is not required in a 2 chassis Chassis system.

You can install this card in slots 1 through 9 in the main cabinet. The card is not supported in the expansion cabinets.

it must be manually programmed in LD 13 (for DTR) and LD 17 (for TDS and TTY).

The TDS/DTR card provides:

- 30 channels of Tone and Digit Switch
- Two Serial Data Interface ports
- 8 tone detection circuits configured as Digitone Receivers

## Features

### Tone transmitter

The TDS/DTR tone transmitter provides 30 channels of tone transmission. Up to 256 tones are available as u-Law or A-Law and up to 256 bursts and cadences are downloaded from the CPU.

The TDS/DTR card does not provide the Music on Hold feature as do other TDS cards. The music source must come from a standard trunk card.

### Tone detector

The TDS/DTR card provides eight channels of DTMF (Dual Tone Multi-Frequency) detection in A-Law or  $\mu$ -Law.

In North America, pre-programmed data is configured for  $\mu$ -Law tone detection.

### SDI function

The TDS/DTR card provides two SDI (Serial Data Interface) ports.

Refer to “SDI ports” in *Installation planning* (553-3001-120) for more information.

## Tones and cadences

The following tables give the tones and cadences provided by the NTAK03 TDS/DTR card.

**Table 278**  
**NTAK03, NTDK20, and NTDK97  $\mu$ -Law tones and cadence (Part 1 of 6)**

Tone #	Frequency (Hz)	dB below overload	Precision Ringing Tones	DTMF Digits	MF Digits
1	350/440	-23/-23	÷		
2	(533 + 666) x 10	-23/-23	÷		
3	440	-23	÷		
4	350/440	-19/-19	÷		
5	440/480	-25/-25	÷		
6	480	-23	÷		
7	480/620	-30/-30	÷		
8	1020	-16	÷		
9	600	-23	÷		
10	600	-16	÷		
11	440/480	-22/-22	÷		
12	350/480	-23/-23	÷		
13	440/620	-24/-24	÷		
14	940/1630	-12/-10		P	
15	700/1210	-12/-10		1	
16	700/1340	-12/-10		2	
17	700/1480	-12/-10		3	
18	770/1210	-12/-10		4	

**Table 278**  
**NTAK03, NTDK20, and NTDK97  $\mu$ -Law tones and cadence (Part 2 of 6)**

Tone #	Frequency (Hz)	dB below overload	Precision Ringing Tones	DTMF Digits	MF Digits
19	770/1340	-12/-10		5	
20	770/1480	-12/-10		6	
21	850/1210	-12/-10		7	
22	850/1340	-12/-10		8	
23	850/1480	-12/-10		9	
24	940/1340	-12/-10		0	
25	940/1210	-12/-10		*	
26	940/1480	-12/-10		#	
27	700/1630	-12/-10		Fo	
28	770/1630	-12/-10		F	
29	850/1630	-12/-10		I	
30	reserved				
31	reserved				
32	reserved				
33	400	-19	÷		
34	[400 x (120@85%)]	-19	÷		
35	940/1630	-17/-15		P	
36	700/1210	-17/-15		1	
37	700/1340	-17/-15		2	
38	700/1480	-17/-15		3	



**Table 278**  
**NTAK03, NTDK20, and NTDK97  $\mu$ -Law tones and cadence (Part 3 of 6)**

Tone #	Frequency (Hz)	dB below overload	Precision Ringing Tones	DTMF Digits	MF Digits
39	770/1210	-17/-15		4	
40	770/1340	-17/-15		5	
41	770/1480	-17/-15		6	
42	850/1210	-17/-15		7	
43	850/1340	-17/-15		8	
44	850/1480	-17/-15		9	
45	940/1340	-17/-15		0	
46	940/1210	-17/-15		*	
47	940/1480	-17/-15		#	
48	700/1630	-17/-15		Fo	
49	770/1630	-17/-15		F	
50	850/1630	-17/-15		I	
51	reserved				
52	reserved				
53	1300/1500	-13/-13			0
54	700/900	-13/-13			1
55	700/1100	-13/-13			2/CC
56	900/1100	-13/-13			3
57	700/1300	-13/-13			4
58	900/1300	-13/-13			5
59	1100/1300	-13/-13			6

**Table 278**  
**NTAK03, NTDK20, and NTDK97  $\mu$ -Law tones and cadence (Part 4 of 6)**

Tone #	Frequency (Hz)	dB below overload	Precision Ringing Tones	DTMF Digits	MF Digits
60	700/1500	-13/-13			7
61	900/1500	-13/-13			8
62	1100/1500	-13/-13			9
63	700/1700	-13/-13			ST3P/RB/ C11
64	900/1700	-13/-13			STP/C12
65	1100/1700	-13/-13			KP/CR/KP1
66	1300/1700	-13/-13			ST2P/KP2
67	1500/1700	-13/-13			ST/CC
68	400	-11	÷		
69	400	-14	÷		
70	400 x 50	-14	÷		
71	(533 + 666) x 20	-23/-23	÷		
72	reserved				
73	350/440	-15/-15	÷		
74	480/620	-15/-15	÷		
75	440/480	-15/-15	÷		
76	400	-25	÷		
77	400/450	-14/-14	÷		
78	480/620	-19/-19	÷		
79	440/480	-19/-19	÷		

**Table 278**  
**NTAK03, NTDK20, and NTDK97  $\mu$ -Law tones and cadence (Part 5 of 6)**

Tone #	Frequency (Hz)	dB below overload	Precision Ringing Tones	DTMF Digits	MF Digits
80	480	-19	÷		
81	420	-9	÷		
82	440	-29	÷		
83	reserved				
84	350/440	-17/-17	÷		
85	400/450	-17/-17	÷		
86	400	-17	÷		
87	1400	-26	÷		
88	950	-12	÷		
89	1400	-12	÷		
90	1800	-12	÷		
91	470	0	÷		
92	940	0	÷		
93	1300	0	÷		
94	1500	0	÷		
95	1880	0	÷		
96	350/440	-10/-10			
97	TBD				
98	TBD				
99	TBD				
100	TBD				

**Table 278**  
**NTAK03, NTDK20, and NTDK97  $\mu$ -Law tones and cadence (Part 6 of 6)**

Tone #	Frequency (Hz)	dB below overload	Precision Ringing Tones	DTMF Digits	MF Digits
101	600	-19	÷		
102	800	-19	÷		
103	1400	-23	÷		
104	820	-7			

*Note:* Tones #1 - 16 (inclusive) and #234 - 249 (inclusive) are included for Norwegian and Malaysian specifications.

**Table 279**  
**NTAK03, NTDK20, and NTDK97 A-Law tones and cadences (Part 1 of 9)**

Tone #	Frequency (Hz)	dB below overload	Precision Ringing Tones	DTMF Digits	MF Digits
1	940 X 1630	-14/-13		P	
2	700 X 1210	-14/-13		1	
3	700 X 1340	-14/-13		2	
4	700 X 1480	-14/-13		3	
5	770 X 1210	-14/-13		4	
6	770 X 1340	-14/-13		5	
7	770 X 1480	-14/-13		6	
8	850 X 1210	-14/-13		7	
9	850 X 1340	-14/-13		8	
10	850 X 1480	-14/-13		9	
11	940 X 1340	-14/-13		0	

**Table 279**  
**NTAK03, NTDK20, and NTDK97 A-Law tones and cadences (Part 2 of 9)**

Tone #	Frequency (Hz)	dB below overload	Precision Ringing Tones	DTMF Digits	MF Digits
12	940 X 1210	-14/-13		*	
13	940 X 1480	-14/-13		#	
14	700 X 1630	-14/-13		F0	
15	770 X 1630	-14/-13		F	
16	850 X 1630	-14/-13		I	
17	1400	-37			
89	940/1630	-13/-12		P	
90	700/1210	-13/-12		1	
91	700/1340	-13/-12		2	
92	700/1480	-13/-12		3	
93	770/1210	-13/-12		4	
94	770/1340	-13/-12		5	
95	770/1480	-13/-12		6	
96	850/1210	-13/-12		7	
97	850/1340	-13/-12		8	
98	850/1480	-13/-12		9	
99	940/1210	-13/-12		0	
100	940/1340	-13/-12		*	
101	940/1480	-13/-12		#	
102	700/1630	-13/-12		F0	
103	770/1630	-13/-12		F0	

**Table 279**  
**NTAK03, NTDK20, and NTDK97 A-Law tones and cadences (Part 3 of 9)**

Tone #	Frequency (Hz)	dB below overload	Precision Ringing Tones	DTMF Digits	MF Digits
104	850/1630	-13/-12		I	
105	350/440	-17/-17	÷		
106	400/450	-17/-17	÷		
107	1400	-26	÷		
108	440	-23	÷		
109	420	-9	÷		
110	950	-12	÷		
111	1400	-12	÷		
112	1800	-12	÷		
113	940/1630	-12/-10		P	
114	700/1210	-12/-10		1	
115	700/1340	-12/-10		2	
116	700/1480	-12/-10		3	
117	770/1210	-12/-10		4	
118	770/1340	-12/-10		5	
119	770/1480	-12/-10		6	
120	850/1210	-12/-10		7	
121	850/1340	-12/-10		8	
122	850/1480	-12/-10		9	
123	940/1340	-12/-10		0	
124	940/1210	-12/-10		*	

**Table 279**  
**NTAK03, NTDK20, and NTDK97 A-Law tones and cadences (Part 4 of 9)**

Tone #	Frequency (Hz)	dB below overload	Precision Ringing Tones	DTMF Digits	MF Digits
125	940/1480	-12/-10		#	
126	700/1630	-12/-10		F0	
127	770/1630	-12/-10		F	
128	850/1630	-12/-10		I	
129	350/440	-22/-22	÷		
130	400	-19	÷		
131	400	-25	÷		
132	400/450	-22/-22	÷		
133	1400	-15	÷		
134	950	-19	÷		
135	1400	-20	÷		
136	1800	-20	÷		
137	420	-19	÷		
138	940/1630	-18/-17		P	
139	700/1210	-18/-17		1	
140	700/1340	-18/-17		2	
141	700/1480	-18/-17		3	
142	770/1210	-18/-17		4	
143	770/1340	-18/-17		5	
144	770/1480	-18/-17		6	
145	850/1210	-18/-17		7	

**Table 279**  
**NTAK03, NTDK20, and NTDK97 A-Law tones and cadences (Part 5 of 9)**

Tone #	Frequency (Hz)	dB below overload	Precision Ringing Tones	DTMF Digits	MF Digits
146	850/1340	-18/-17	÷	8	
147	850/1480	-18/-17	÷	9	
148	940/1340	-18/-17	÷	0	
149	940/1210	-18/-17	÷	*	
150	940/1480	-18/-17	÷	#	
151	700/1630	-18/-17		F0	
152	770/1630	-18/-17		F	
153	850/1630	-18/-17		I	
154	(533 + 666) X 10	-23	÷		
155	(533 + 666) X 20	-23	÷		
156	400	-12	÷		
157	820	-14	÷		
158	420	-12	÷		
159	420	-25	÷		
160	420 X 25	-12	÷		
161	(553 + 666) X 10	-23	÷		
162	(553 + 666) X 20	-23	÷		
163	420	-22	÷		
164	480	-22	÷		
165	330	-11	÷		
166	330/440	-11/-14	÷		



**Table 279**  
**NTAK03, NTDK20, and NTDK97 A-Law tones and cadences (Part 6 of 9)**

Tone #	Frequency (Hz)	dB below overload	Precision Ringing Tones	DTMF Digits	MF Digits
167	1700	-19	÷		
168	440	-14	÷		
169	380	-8	÷		
170	1400	-32	÷		
171	820	-7		P	
172	850	-8		1	
173	420	-32		2	
174	reserved			3	
175	420	-6		4	
176	420	-2		5	
177	1020	-13		6	
178	1800	-17		7	
179	1400	-23		8	
180	950	-29		9	
181	1400	-29		0	
182	1800	-29		*	
183	950	-22		#	
184	470	0		F0	
185	940	0		F	
186	1880	0		I	
187	400	-22			

**Table 279**  
**NTAK03, NTDK20, and NTDK97 A-Law tones and cadences (Part 7 of 9)**

<b>Tone #</b>	<b>Frequency (Hz)</b>	<b>dB below overload</b>	<b>Precision Ringing Tones</b>	<b>DTMF Digits</b>	<b>MF Digits</b>
188	420 X 25	-17			
189	950	-16			
190	950	-25			
191	940/1630	-9/-7			
192	700/1210	-9/-7			
193	700/1340	-9/-7			
194	700/1480	-9/-7			
195	770/1210	-9/-7			
196	770/1340	-9/-7			
197	770/1480	-9/-7			
198	850/1210	-9/-7			
199	850/1340	-9/-7			
200	850/1480	-9/-7			
201	940/1340	-9/-7			
202	940/1210	-9/-7			
203	940/1480	-9/-7			
204	700/1630	-9/-7			
205	770/1630	-9/-7			
206	850/1630	-9/-7			
207	420	-10			
208	420	-8			

**Table 279**  
**NTAK03, NTDK20, and NTDK97 A-Law tones and cadences (Part 8 of 9)**

Tone #	Frequency (Hz)	dB below overload	Precision Ringing Tones	DTMF Digits	MF Digits
209	420	-4			
210	1400	-18			
211	1400	-9			
212	350/420	-9/-9			
213	420	-14			
214	450	-12			
215	450	-22			
216	820	-16			
217	350/420	-14/-14			
218	940/1630	-14/-12			
219	700/1210	-14/-12			
220	700/1340	-14/-12			
221	700/1480	-14/-12			
222	770/1210	-14/-12			
223	770/1340	-14/-12			
224	770/1480	-14/-12			
225	850/1210	-14/-12			
226	850/1340	-14/-12			
227	850/1480	-14/-12			
228	940/1340	-14/-12			
229	940/1210	-14/-12			

**Table 279**  
**NTAK03, NTDK20, and NTDK97 A-Law tones and cadences (Part 9 of 9)**

<b>Tone #</b>	<b>Frequency (Hz)</b>	<b>dB below overload</b>	<b>Precision Ringing Tones</b>	<b>DTMF Digits</b>	<b>MF Digits</b>
230	940/1480	-14/-12			
231	700/1630	-14/-12			
232	770/1630	-14/-12			
233	850/1630	-14/-12			
234	940 X 1630	-17/-15		p	
235	700 X 1210	-17/-15		1	
236	700 X 1340	-17/-15		2	
237	700 X 1480	-17/-15		3	
238	770 X 1210	-17/-15		4	
239	770 X 1340	-17/-15		5	
240	770 X 1480	-17/-15		6	
241	850 X 1210	-17/-15		7	

---

# Appendix A: LAPB Data Link Control protocol

---

## Contents

This section contains information on the following topics:

Introduction . . . . .	901
Operation . . . . .	901
Frame structure . . . . .	902
LAPB balanced class of procedure . . . . .	903
Commands and responses . . . . .	904
Description of procedure . . . . .	905

## Introduction

This chapter describes the LAPB Data Link Control protocol used with the QPC513 ESDI card. The protocol is a subset of the HDLC procedures which are described in International Organization for Standardization procedures ISO 3309-1979 (E), ISO 4335-1979 (E) and appendices 1 and 2, and ISO 6256-1981 (E). Refer to these procedures for complete LAPB details.

Applications which use an ESDI port in synchronous mode must conform to the following requirements.

## Operation

Circuit Switch Equipment transfers data to the QPC513 in blocks consisting of 1 to 128 eight-bit octets. Each block is processed in accordance with the

LAPB subset of the HDLC protocol and transmitted serially to the line at a rate determined by the downloaded parameters.

The QPC513 card receives data serially from the line, packaged in LAPB information frames. After determining that a block is error free the data is supplied to the Circuit Switch Equipment as a block.

## Frame structure

All transmissions are in frames and each frame conforms to the format shown in Table 280 on [page 903](#). In particular, frame elements for applications using a port on the QPC513 follow these LAPB conventions:

- Zero information field is permitted.
- Inter-frame time fill is accomplished by transmitting contiguous flags. This is compatible with AT&T Technical Requirement BX.25 and ADCCP standards.
- Extensions for the address field or the control field are not permitted. This requirement imposes constraints to satellite operations.
- Individual station addresses are assigned in service change for balanced configuration. The default ESDI address is 10000000. The far-end default address is 11000000.
- The LAPB basic control field (modules 8) format is implemented.
- Frame check sequence is implemented in accordance with LAPB procedures.

**Table 280**  
**LAPB frame structure**

Flag	Address	Control	Information	FCS	Flag
01111110	8 bits	8 bits	unspecified (no. of bits)	16 bits	01111110

**Legend:**

Flag: Flag sequence – All frames start and end with the flag sequence. (A single flag is used as both the closing flag for one frame and the opening flag for the next frame.)

Address: Station address field – In command frames, the address identifies the station for whom the command is intended. In response frames, the address identifies the station from which the response originated.

Control: Control field – This field contains commands or responses and sequence numbers.

Information: Information field – Information may be any sequence of bits, usually related to a convenient character structure such as an octet, but may be an unspecified number (from 1 to 128) of bits unrelated to a character structure.

FCS: Frame check sequence.

## LAPB balanced class of procedure

Applications which use ports on the QPC513 are automatically designated as BAC, 2, 8 (for example, balanced operation, asynchronous balanced mode class of procedure with optional functions 2 and 8 implemented).

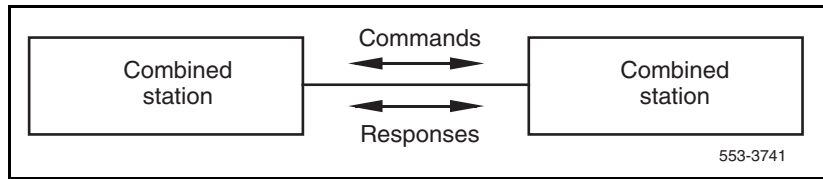
### Balanced configuration

A balanced configuration is one in which two combined stations have identical responsibilities for exchanging data and control information and for initiating error recovery functions, as shown in Figure 191 on [page 904](#).

### Combined station

A combined station has balanced link control capability and transmits both commands and responses to, and receives both commands and responses from the other combined station.

**Figure 191**  
**Balanced configuration**



### **Asynchronous Balanced Mode**

Asynchronous Balanced Mode (ABM) is a balanced, configured operational mode in which either combined station may send commands at any time and may initiate certain response frame transmissions without receiving permission from the other combined station.

## **Commands and responses**

The elements of procedure are described in terms of actions which take place when a command is received. The classes of procedures are a combination of the frame structure and the set of elements that satisfy the requirements of a specific application. The LAPB Balanced Asynchronous Class of Procedure (BAC, 2, 8) is implemented. This is compatible with both BX.25 and ADCCP specifications. The basic set of commands and responses is listed in Table 281 on [page 905](#).



**Table 281**  
**Commands and responses**

Command	Response	Option
I		8
RR	RR	
RNR	RNR	
REJ	REJ or FRMR	2
SABM	UA	
DISC	DM	

**Legend:**  
I: Information  
RR: Receive ready  
RNR: Receive not ready  
REJ: Reject  
SABM: Set asynchronous balanced mode  
DISC: Disconnect  
RSET: Reset  
FRMR: Frame reject  
UA: Unnumbered acknowledge  
DM: Disconnect mode  
Option 2: Provides ability for more timely reporting of I frame sequence errors  
Option 8: Limits the procedure to allow I frames to be commands only

## Description of procedure

The basic LAPB procedures must be implemented to satisfy the following:

- standard use of the poll/final bit (for more information, see ISO-4375-1979-[E])
- exception condition reporting and recovery implemented in accordance with BX.25 and ADCCP specifications
- link set-up and disconnect implemented according to BX.25 specifications





Nortel Communication Server 1000

## **Circuit Card**

### Description and Installation

Copyright © Nortel Networks Limited 2005  
All Rights Reserved

Information is subject to change without notice.  
Nortel Networks reserves the right to make changes in design  
or components as progress in engineering and manufacturing  
may warrant.

Nortel, Nortel (Logo), the Globemark, This is the Way, This is  
Nortel (Design mark), SL-1, Meridian 1, and Succession are  
trademarks of Nortel Networks.

Publication number: 553-3001-211  
Document release: Standard 3.00  
Date: August 2005  
Produced in Canada



>THIS IS **THE WAY**

>THIS IS **NORTEL™**